

DOCUMENT RESUME

ED 119 887

RC 009 027

TITLE Arizona TeleMedicine Network: Segment Specifications--Tuba City via Mt. Elden, Phoenix; Keams Canyon, Second Mesa, Low Mountain; Phoenix, San Carlos, Bylas; Keams Canyon via Ganado Mesa, Ft. Defiance; Tuba City via Black Mesa, Ft. Defiance; and Budgetary Cost Information--Pinal Peak via San Xavier, Tucson.

INSTITUTION Arizona Univ., Tucson. Coll. of Medicine.; Atlantic Research Corp., Alexandria, Va.

SPONS AGENCY Office of Economic Opportunity, Washington, D.C.

REPORT NO OEO-B2C-5379

PUB DATE 30 May 73

NOTE 226p.; Some maps, charts, and photographs may not reproduce clearly due to marginal quality or original; Related documents are RC 009 023-026

EDRS PRICE MF-\$0.83 HC-\$12.71 Plus Postage

DESCRIPTORS *American Indians; Budgets; Design; Equipment; Geographic Location; *Health Services; Maps; Networks; Photographs; *Rural Areas; *Site Analysis; Specifications; *Telecommunication

IDENTIFIERS *Arizona TeleMedicine Project

ABSTRACT

The communication links of five different segments of the Arizona TeleMedicine Network (a telecommunication system designed to provide health services for American Indians in rurally isolated areas) and budgetary cost information for Pinal Peak via San Xavier and Tucson are described in this document. The five communication links are identified as: (1) Keams Canyon Hospital, the field health station at Second Mesa and the field health station at Low Mountain via a switching relay at Keams Canyon; (2) the Phoenix Indian Medical Center and a peripheral hospital at Tuba City via relays at Shaw Butte, Mingus Mountain, Mount Elden, and Graveyard Junction; (3) the Phoenix Indian Medical Center, a peripheral hospital at San Carlos, and the field health station at Bylas via a switching relay at Pinal Peak; (4) Keams Canyon Relay and Ganado Mesa Relay via a relay at Steamboat Junction with Administrative Voice Channels extended to Keams Canyon Hospital and Fort Defiance Hospital; (5) switching relays at Shonto, Black Mesa, and Yale Point. Each communication link is identified in terms of: (1) Scope; (2) System Design (communication channels, selection of microwave routes, control of signal switching); (3) Applicable Documents (regulatory); (4) Spare Equipment and Materials Requirements; (5) Path Profiles; (6) Site Maps; (7) Site Photographs; and (8) Drawings. (JC)

ED119887

Arizona TeleMedicine Network

U.S. DEPARTMENT OF HEALTH,
EDUCATION & WELFARE
NATIONAL INSTITUTE OF
EDUCATION

THIS DOCUMENT HAS BEEN REPRODUCED EXACTLY AS RECEIVED FROM THE PERSON OR ORGANIZATION ORIGINATING IT. POINTS OF VIEW OR OPINIONS STATED DO NOT NECESSARILY REPRESENT OFFICIAL NATIONAL INSTITUTE OF EDUCATION POSITION OR POLICY

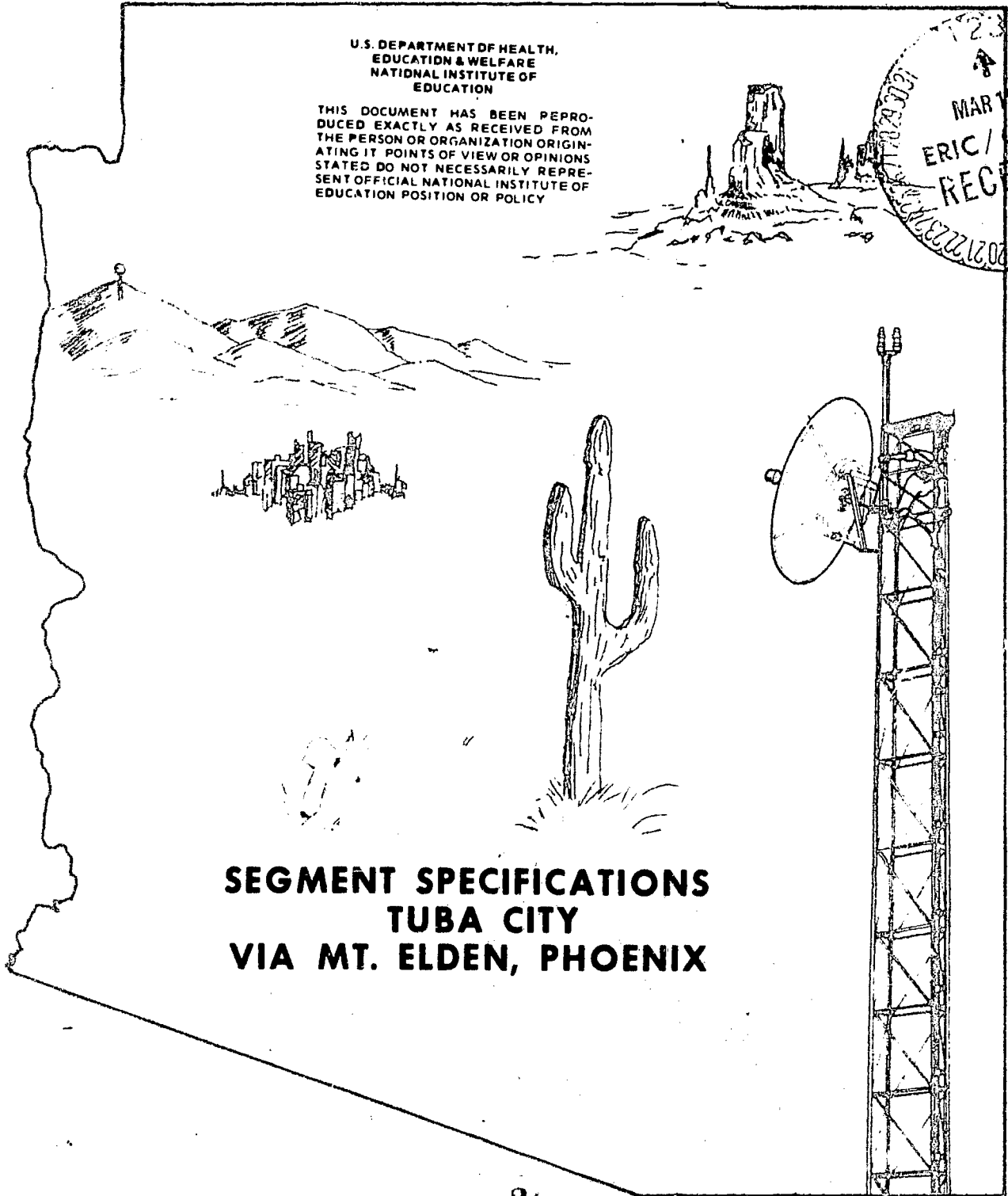
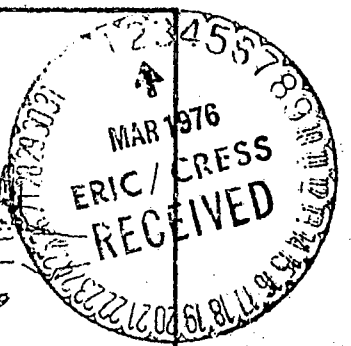

**SEGMENT SPECIFICATIONS
TUBA CITY
VIA MT. ELDEN, PHOENIX**

RC009027



THE ARIZONA TELEMEDICINE NETWORK

SEGMENT SPECIFICATIONS

Tuba City, via Mt. Elden, Phoenix

Prepared for:

**The University of Arizona College of Medicine
Department of Family and Community Medicine
Tucson, Arizona 85724**

Prepared by:

**The Biomedical and Special Systems Group
Telecommunications Activity
Atlantic Research Corporation
Alexandria, Virginia 22314**

May 30, 1973

TABLE OF CONTENTS

	Page
1.0 SCOPE	1-1
2.0 SYSTEM DESIGN	2-1
2.1 Communications Channels	2-1
2.2 Selection of Microwave Routes	2-2
2.3 Control of Signal Switching	2-3
2.3.1 Graveyard Junction Switch Point (Class "R1" Station)	2-4
2.3.2 Mt. Elden Switch Point (Class "R1" Station)	2-5
2.3.3 Phoenix Switch Point (Class "c" Station)	2-5
2.3.4 Control Panel at Tuba City	2-6
2.3.5 Control Panel at Phoenix	2-6
2.3.6 Administrative Voice Channel	2-6
3.0 APPLICABLE DOCUMENTS	3-1
4.0 SPARE EQUIPMENT AND MATERIALS REQUIREMENT	4-1
APPENDIX A – Path Profile	
APPENDIX B – Site Maps	
APPENDIX C – Site Photographs	
APPENDIX D – Drawings	

1.0 SCOPE

This document defines one segment of the Arizona TeleMedicine Network as referred to in the System Procurement Specifications. The basic requirements shall be as given by the general document as amended by unique requirements for this segment given herein.

The segment defined here is a communication link between the Phoenix Indian Medical Center and a peripheral hospital at Tuba City via relays at Shaw Butte, Mingus Mt., Mt. Elden, and Graveyard Junction. Figure 1.1 illustrates this segment.

This document describes all equipment required to implement the segment and details all allowances to be made to facilitate anticipated expansions to the network.

- ⊕ First Level Referral Center
- Second Level Referral Center
- Switching Relay
- △ Repeater Relay
- Microwave Path Requested this Segment
- Voice Channel Required this Segment
- - - - Proposed or Existing Communication Paths (not part of this segment)

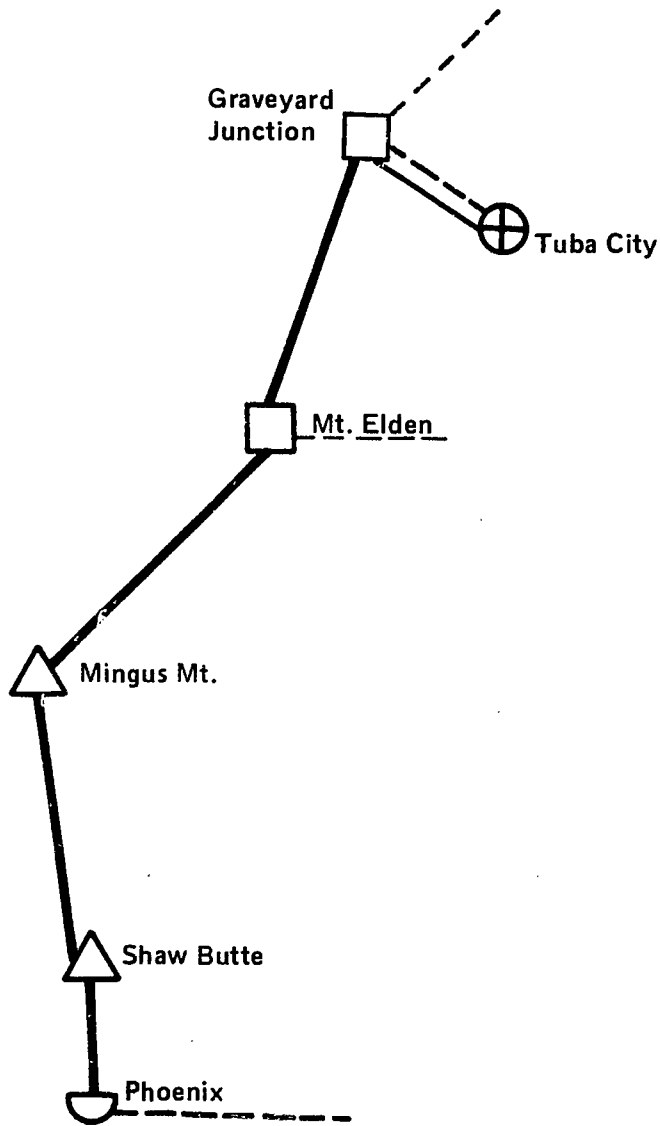

Figure 1.1. Tuba City, via Mt. Elden, Phoenix Segment.

2.0 SYSTEM DESIGN

2.1 Communications Channels

The full duplex microwave segment shall be channelized to carry the following services.

- Full color television (525 line/30 frame with 5.5 MHz bandpass) – one channel
- Program audio (15 kHz bandpass) – one channel
- Order wire (with selective signaling) – one channel
- “Voice” slots (FDM, 4 kHz spacing) – up to 12 channels
- Alarm circuits – see channelization plan.

A further breakdown of the use of the “voice” slots is included in the suggested spectrum utilization plans for each link within the segment (see Appendix D.1).

The designated voice slots shown are to be used for the following services:

- Camera positioning control (tilt, pan, focus, zoom, iris, mono/color) – six channels (dc control) per voice slot
- Teleprinter/keyboard (300 baud) – six channels per voice slot, one channel per site
- Telemetry (IRIG Standard) dc to 500 Hz – one channel, single voice slot per site
- Slow-scan television (approximately one frame per two-minute interval) – one channel, single voice slot
- Switching control relay sites, remote – touch tones, share administrative voice slot
- Administrative Voice Channel(s) – see channelization plan.

Locations in the network shall be provided with modems, FSK transmitter/receivers, FM telemetry devices and such interface equipment as required to facilitate these services at each terminal site.

2.2 Selection of Microwave Routes

The suggested sites for this segment are described as follows. Path profiles, site maps, photographs and drawings are provided in Appendices A, B, C and D, respectively.

Tuba City Hospital

The Contractor shall consider this terminal site as previously developed. The requirement for this segment is to install the administrative voice channel to Phoenix and the associated switching and control functions applicable to this segment. The site at Tuba City Hospital is linked to the switching relay at Graveyard Junction via a cable (previously installed).

Graveyard Junction

This site is to be shared with Navajo Communications Inc., a private telephone company. This site shall be considered implemented, by another segment of the Arizona TeleMedicine Project, with an equipment building and a tower of sufficient strength and height. Commercial power and standby power shall be assumed to be available. The Contractor shall install the necessary antenna (to the south), radio equipment and channelizing equipment to implement the link to Mt. Elden.

Mt. Elden

Site space is available for lease from communication companies in the area. One such facility available for lease is from General Communications Inc. of Tucson. At this site an existing tower must be replaced with a new tower of sufficient strength for an existing 8-foot-diameter antenna and the two antennas required for the Arizona TeleMedicine Project. Allowance including wind and ice load shall be made for the addition of at least two 8-foot parabolic antennas near the top of the tower. The Contractor shall have the responsibility of assuring minimal interruption of the existing radio service and restoration of this service upon completion of installation. The Contractor shall incur all expenses related to the remounting of the existing antenna. An existing heated building is available with equipment space and commercial and standby power. Access to the site is via a dirt road approximately 6 miles from the paved highway.

Mingus Mt.

Site space is available for lease from Nelson Communications Inc., of Phoenix, Arizona. At this site a new tower must be erected. The tower shall be capable of supporting the two specified parabolic antennas. Allowance, including wind and ice loads, shall be made for the addition of at least two 8-foot parabolic antennas near the top of the tower. An existing heated building is available for equipment racks. Commercial and standby power is also available. Access is via a dirt road approximately 8 miles from a paved highway.

Shaw Butte

Site space is available for lease from Nelson Communications Inc., of Phoenix, Arizona. At this site an existing tower shall be replaced with a new tower of sufficient strength for the existing radio antenna and the two parabolic antennas required for the Arizona TeleMedicine Project. The Contractor shall have the responsibility of assuring minimal interruption of existing radio service and restoration of this service upon completion of installation. The Contractor shall incur all expenses related to the remounting of the existing antenna.

An equipment building is required at this site. Commercial power is available; however, standby power must be provided.

Access is via a dirt road approximately 1 mile from a paved road.

Phoenix

At this site, the Contractor shall assume that a stub tower has been installed atop the roof of the Phoenix Indian Medical Center. An equipment building with the necessary rack space and power has been provided. The Contractor shall install the antenna, necessary radio and channelizing equipment to complete the link from Shaw Butte. At this site control and signaling functions are also required.

2.3 Control of Signal Switching

In this segment of the Arizona TeleMedicine Network, the following control and switching relationships shall prevail:

Switching Relay	Control Station
Graveyard Junction	Tuba City
Mt. Elden	Phoenix
Phoenix	Phoenix

Refer to the system procurement specifications document for a general discussion of switching concepts.

The various switch configurations for each switch point are described in the following paragraphs. Note that blank panels are to be provided for switching functions which will be added as the network expands. However, if a portion of a switch matrix is to be used in this segment, the entire matrix shall be installed. Only the switch positions specifically called out in this segment are to be wired.

Each Class "b" or Class "c" station will have installed, when applicable, as an integral part of its control panel, a group of illuminated push buttons which control the origin of the station's switching control tones. These tones will be generated by oscillator modules that produce the dual frequency notes commonly called "touch tones." Depending on which set of tones is generated over which Administrative Voice Channel, a particular cross point on a matrix located at a remote switching relay station will be energized.

2.3.1 Graveyard Junction Switch Point (Class "R1" Station)

General

At this site for this segment two transmitter/receiver (T/R) pairs¹ are brought together for switching. They are listed below:

Mt. Elden	This T/R pair links Mt. Elden switching relay with the Graveyard Junction switching center.
Tuba City	This T/R pair (cable link) links the Tuba City Hospital with the Graveyard Junction switching relay.

¹Up to one transmitter/receiver pair will be or has been added as the network expands. Allowance shall be made for rack space and power requirements.

In remote command of various switch configurations at Graveyard Junction is Tuba City, a Class "b" station. The control tones, originated by Tuba City used to actuate the Graveyard Junction switching equipment, are carried via the Tuba City to Kaibito administrative voice channel. In general, each transmit and receive circuit of the duplex link is switched separately.

The Contractor shall install all existing (T/R) pairs to the switch matrix. The Contractor shall also install all necessary tone and control equipment at the Graveyard Junction and Tuba City sites.

2.3.2 Mt. Elden Switch Point (Class "R1" Station)

General

In this segment two transmitter/receiver (T/R) microwave pairs¹ come together at Mt. Elden switching relay site. They are listed below:

Graveyard Junction	This T/R pair links the relay at Graveyard Junction with the switching relay at Mt. Elden.
--------------------	--

Mingus Mt.	This T/R pair links the relay at Mingus Mt. with the switching relay at Mt. Elden.
------------	--

For this segment, these two (T/R) pairs do not require switching. Therefore the switching matrix and associated control equipment at Mt. Elden shall not be installed as part of this segment. However, the Contractor shall install microwave radio equipment which will allow for switching at a future time.

2.3.3 Phoenix Switch Point (Class "c" Station)

General

In this segment two transmitter/receiver (T/R) pair¹ are terminated at this site. They are a pair from the relay at Shaw Butte to Phoenix and a pair from the switching equipment at Phoenix to the local terminal equipment at Phoenix.

¹Up to one transmitter/receiver pair will be added as the network expands. Allowance shall be made for rack space and power requirements.

Phoenix is in remote command of the switching equipment at the Phoenix switch point. The control tones used to actuate the switching equipment are carried via hard wire from the control room to the switching equipment.

2.3.4 Control Panel at Tuba City

A drawing of the switching and control panel at Tuba City is shown in Figure D.6. The drawing shows the switching requirement for the video, slow-scan TV and telemetry functions for control of the Graveyard Junction switch point. Other switching functions will be added as the network expands.

2.3.5 Control Panel at Phoenix

A drawing of the switching and control panel at Phoenix is shown in Figure D.7. The drawing shows the switching requirement for the video, slow-scan TV and telemetry function for control of the Phoenix switch point. Other switching functions will be added as the network expands.

2.3.6 Administrative Voice Channel

Panel layout drawings for the Administrative Voice Channel at Tuba City and Phoenix are provided in Figures D.8 and D.9.

3.0

APPLICABLE DOCUMENTS

The Arizona TeleMedicine Network,
System Procurement Specifications, May 1973

3-1

13

4.0

SPARE EQUIPMENT AND MATERIALS REQUIREMENT

The Contractor shall, as part of this construction contract, supply the following list of spare parts, components, panels, equipment and material. Delivery shall be to the site as stipulated by the Project Director. Delivery shall be effected prior to final acceptance.

- 1 set Modules for multiplex equipment (12 channels)

- 1 set Common equipment modules, panels and circuit boards (not channel dependent) for microwave radio equipment for both 6 GHz and 12 GHz units

- 4 each Video switcher modules

- 4 each Audio frequency switcher modules

- 4 boxes Fuses of all types

age 3-2 is blank.

APPENDIX A

PATH PROFILE

Note: When towers are not specified on the Vertical Earth Profiles, only minimum tower heights governed by antenna size, will be required.

Note: Corrections for earth curvature and Fresnel zone radius have been included on each profile:

△ 0.3 first Fresnel zone radius

△ earth curvature for $k = 2/3$

A-1

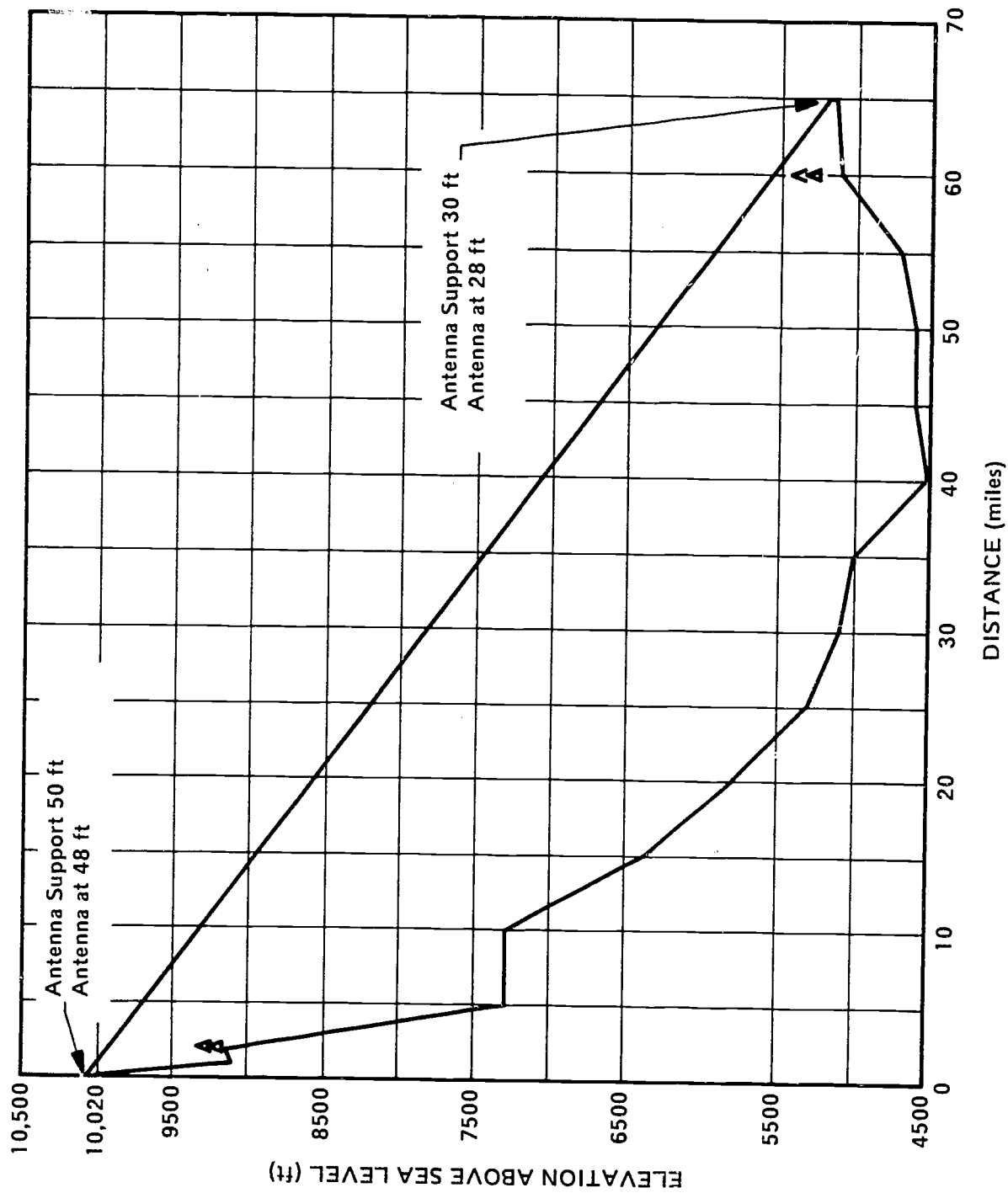

Figure A.1. Vertical Earth Profile, Mt. Elden to Graveyard Junction.

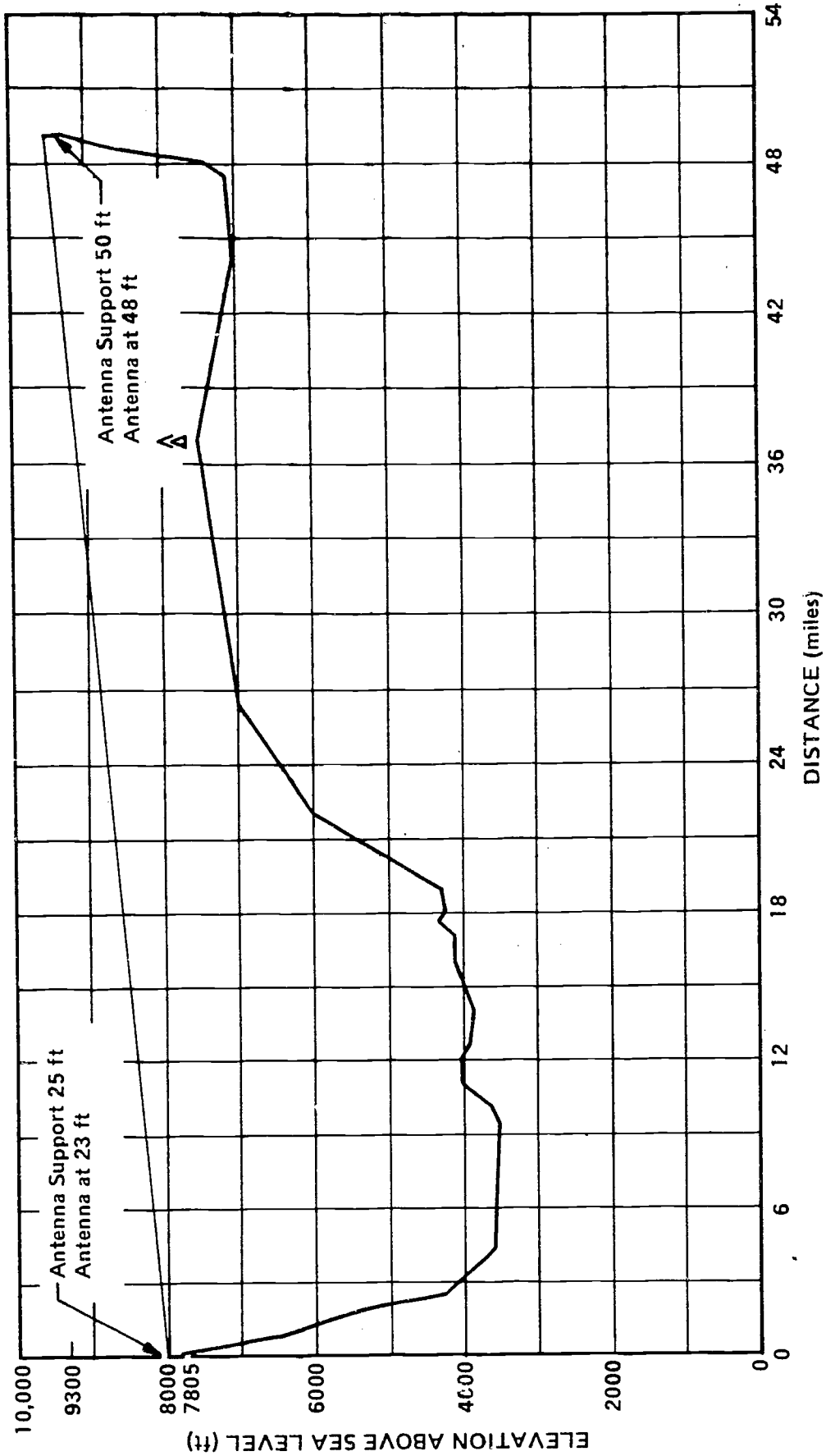

Figure A.2. Microwave Path Profile, Mingus Mountain to Elden Mountain.

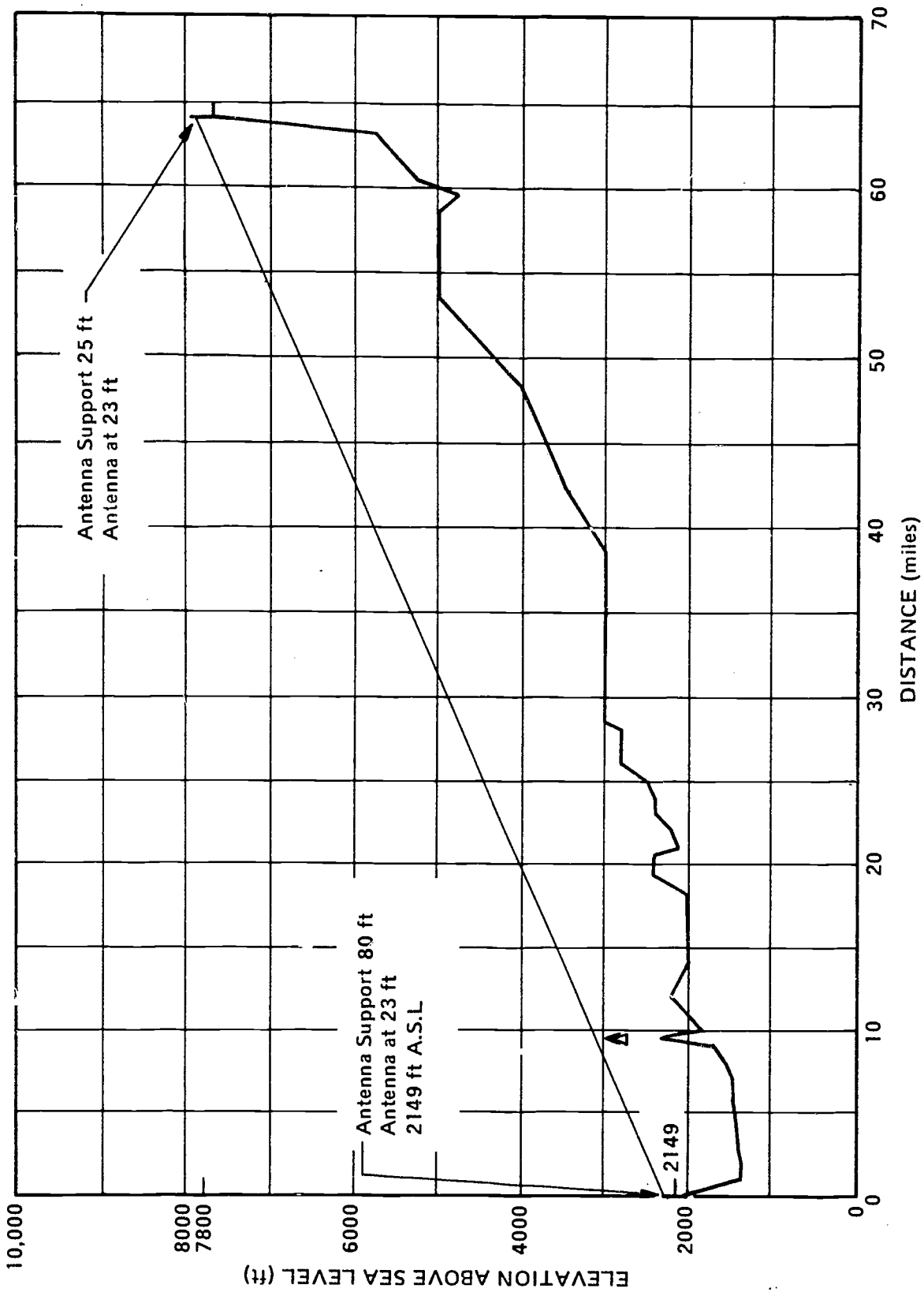
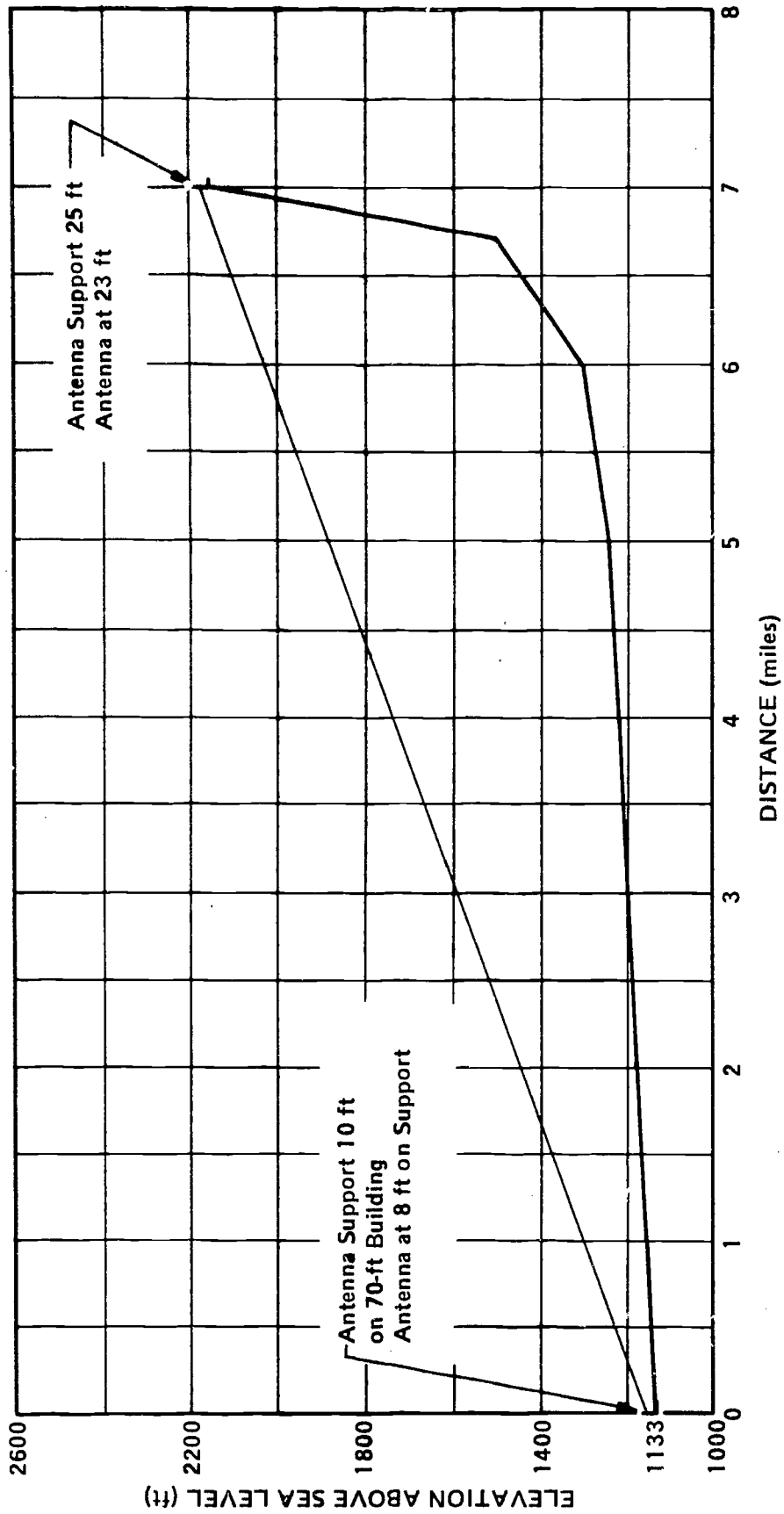

Figure A.3. Microwave Path Profile, Shaw Butte to Mingus Mountain.



A-5

Figure A.4. Microwave Path Profile, Phoenix to Shaw Butte.

APPENDIX B

SITE MAPS

B-1

20

page A-6 is blank.

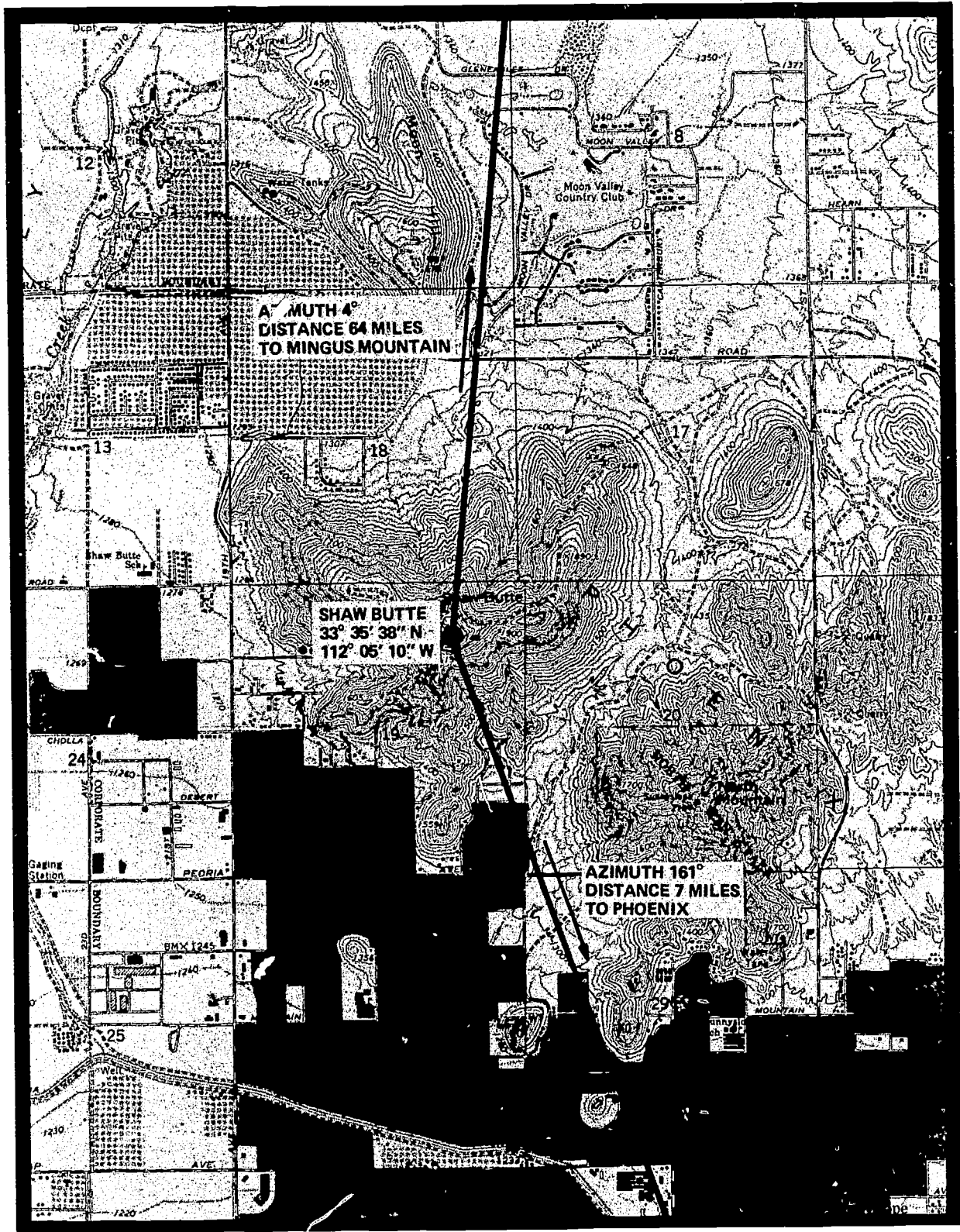

Figure B.2. Shaw Butte Site Map.

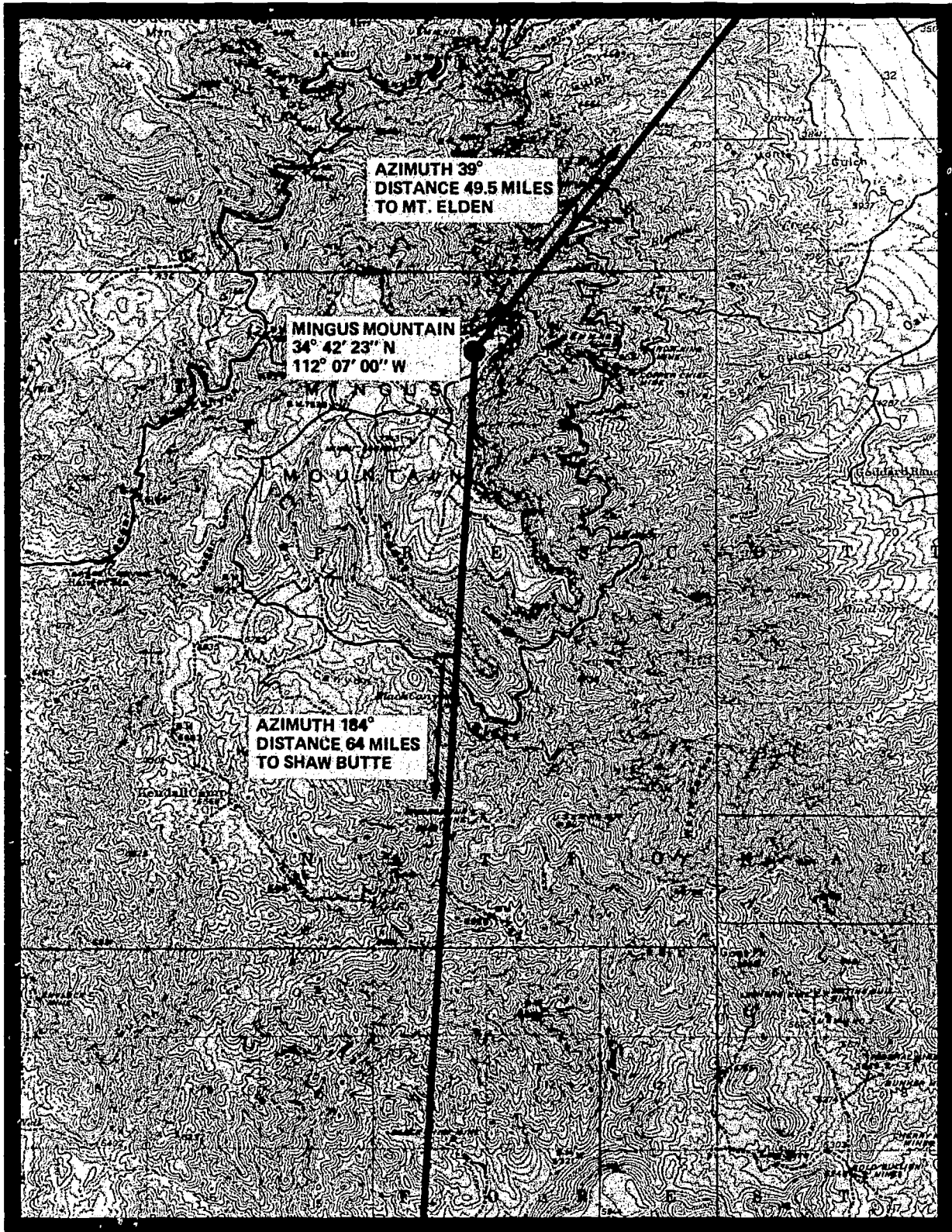

Figure B.3. Mingus Mountain Site Map.

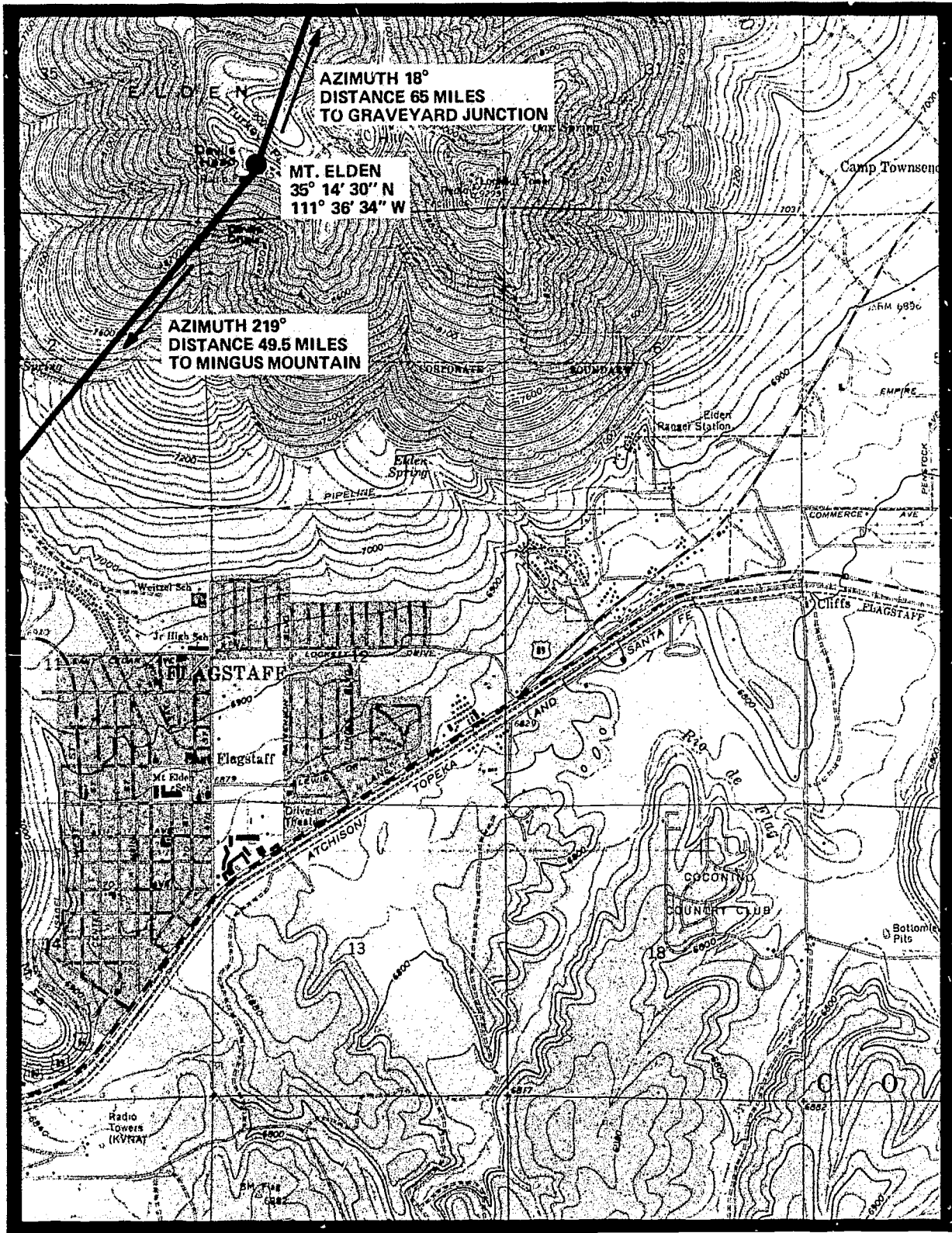

Figure B.4. Mt. Elden Site Map.

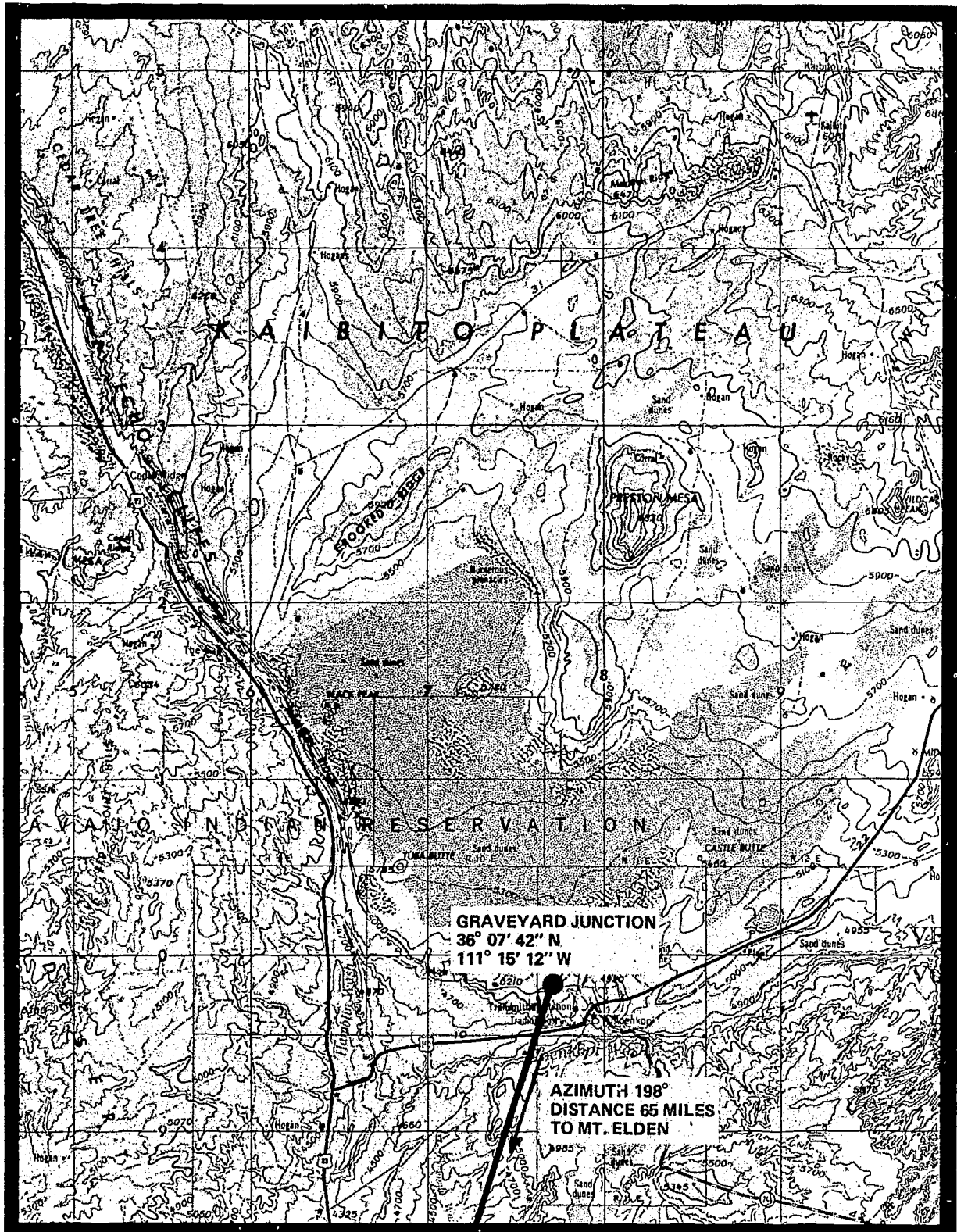

Figure B.5. Graveyard Junction Site Map.

APPENDIX C

SITE PHOTOGRAPHS

C-1



Figure C.1. View of Tuba City Hospital.

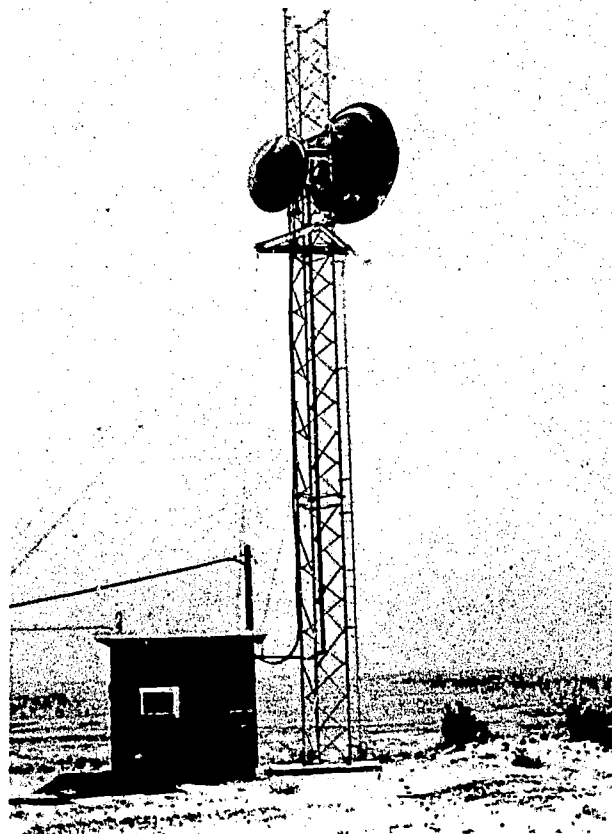

Figure C.2. View of Navajo Communications Facilities at Graveyard Junction.



Figure C.3. Mt. Elden, View of Existing Tower.

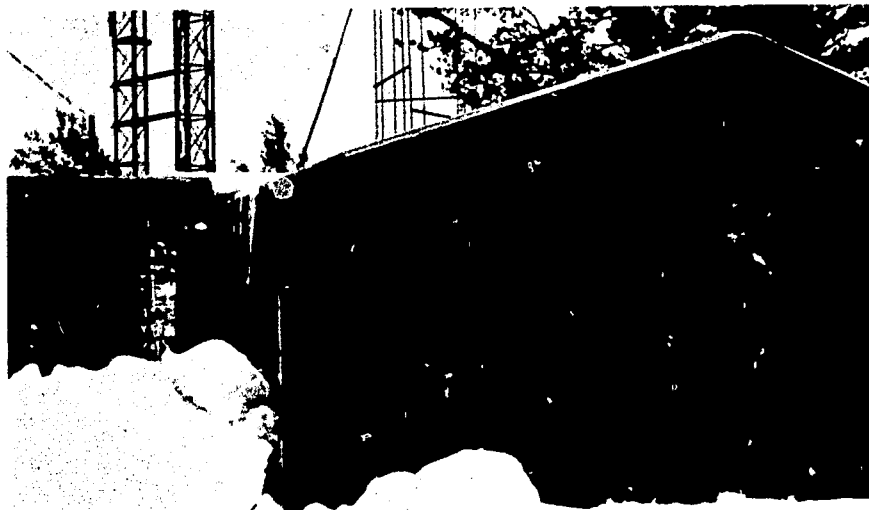

Figure C.4. Mt. Elden, View of Equipment Building.

No Photograph Available

Figure C.5. Mingus Mt. Communication Facilities.



Figure C.6. Shaw Butte Showing Tower Base and Power Installation.

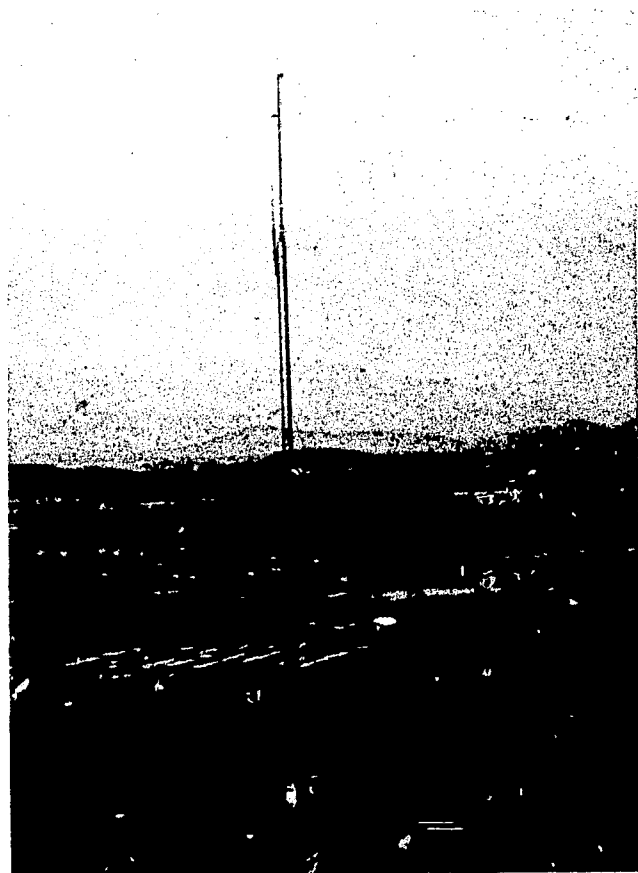

Figure C.7. Shaw Butte, Showing Existing 80-ft Tower.

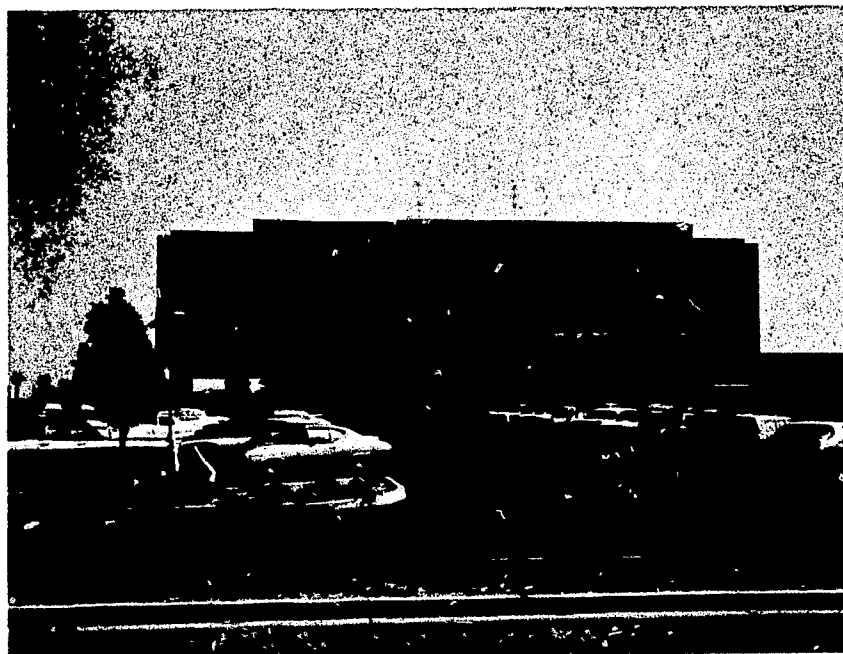

Figure C.8. Phoenix Indian Medical Center.

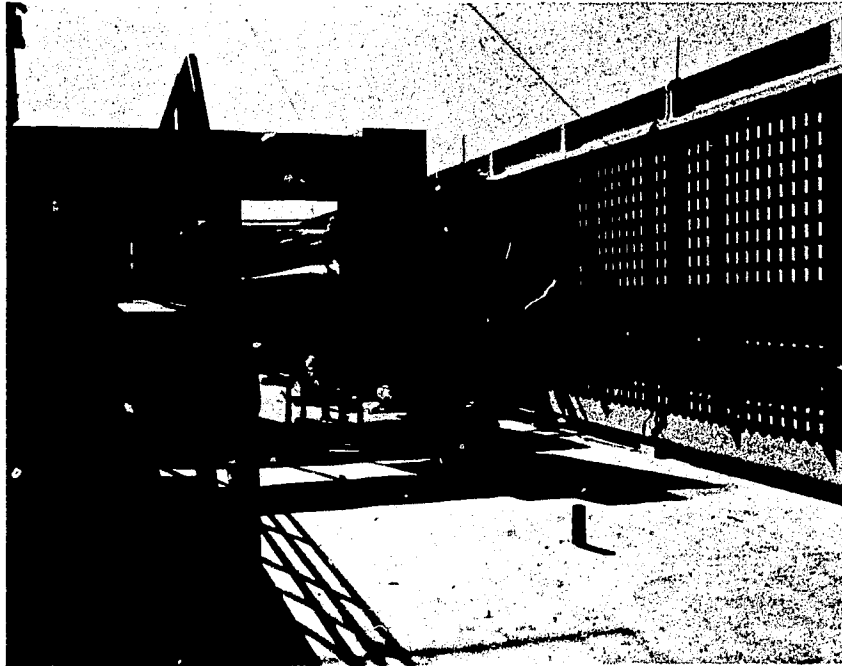
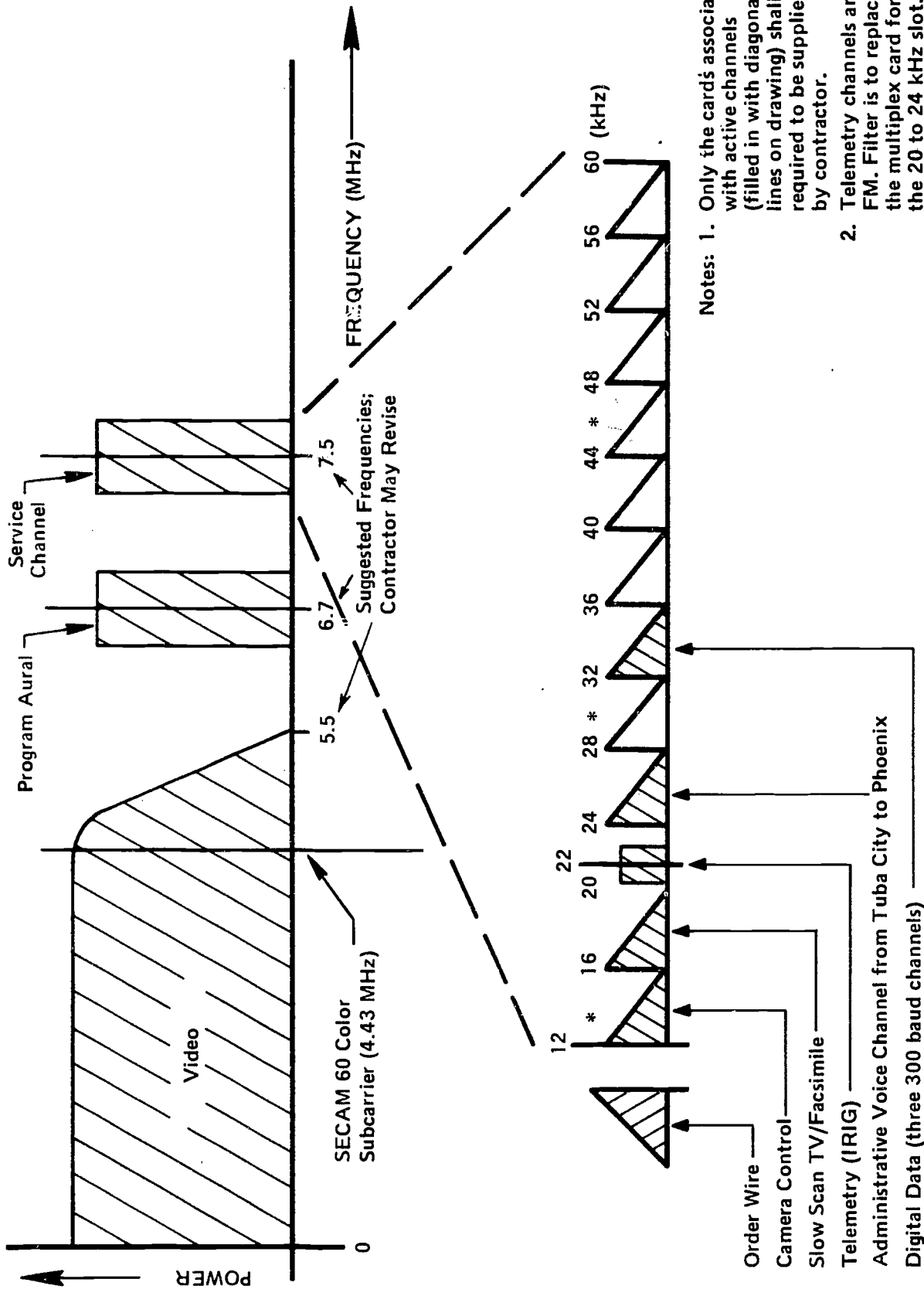

Figure C.9. View of Site of Proposed Equipment Building
Atop the Phoenix Indian Medical Center.

APPENDIX D

DRAWINGS

D-1



Notes: 1. Only the cards associated with active channels (filled in with diagonal lines on drawing) shall be required to be supplied by contractor.

2. Telemetry channels are FM. Filter is to replace the multiplex card for the 20 to 24 kHz slot.

*Indicates channels with expected high noise level.

Figure D.1. Channelization Plan, Link from Graveyard Junction to Phoenix.

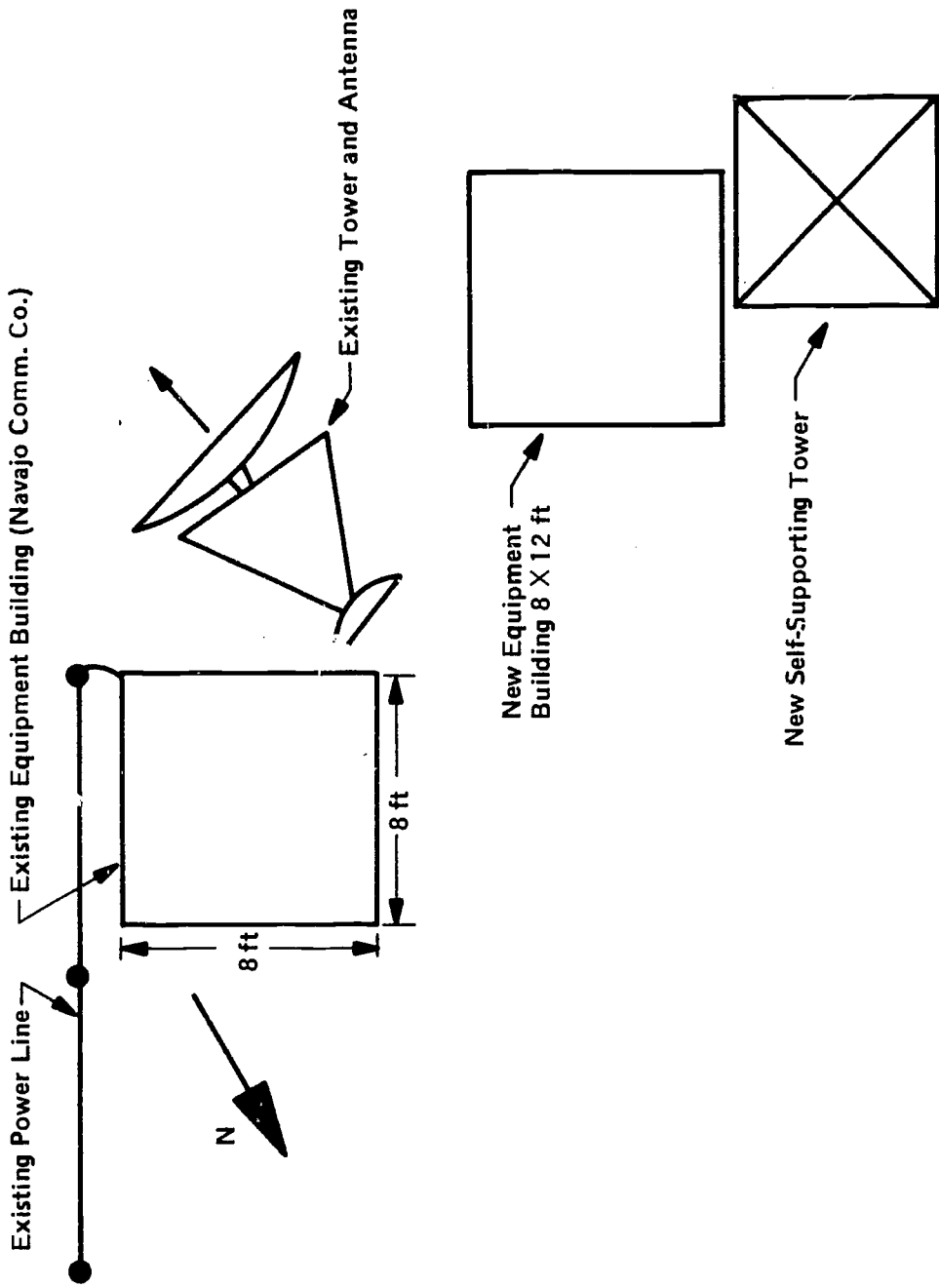

Figure D.2. Existing and Proposed Facilities at Graveyard Junction.

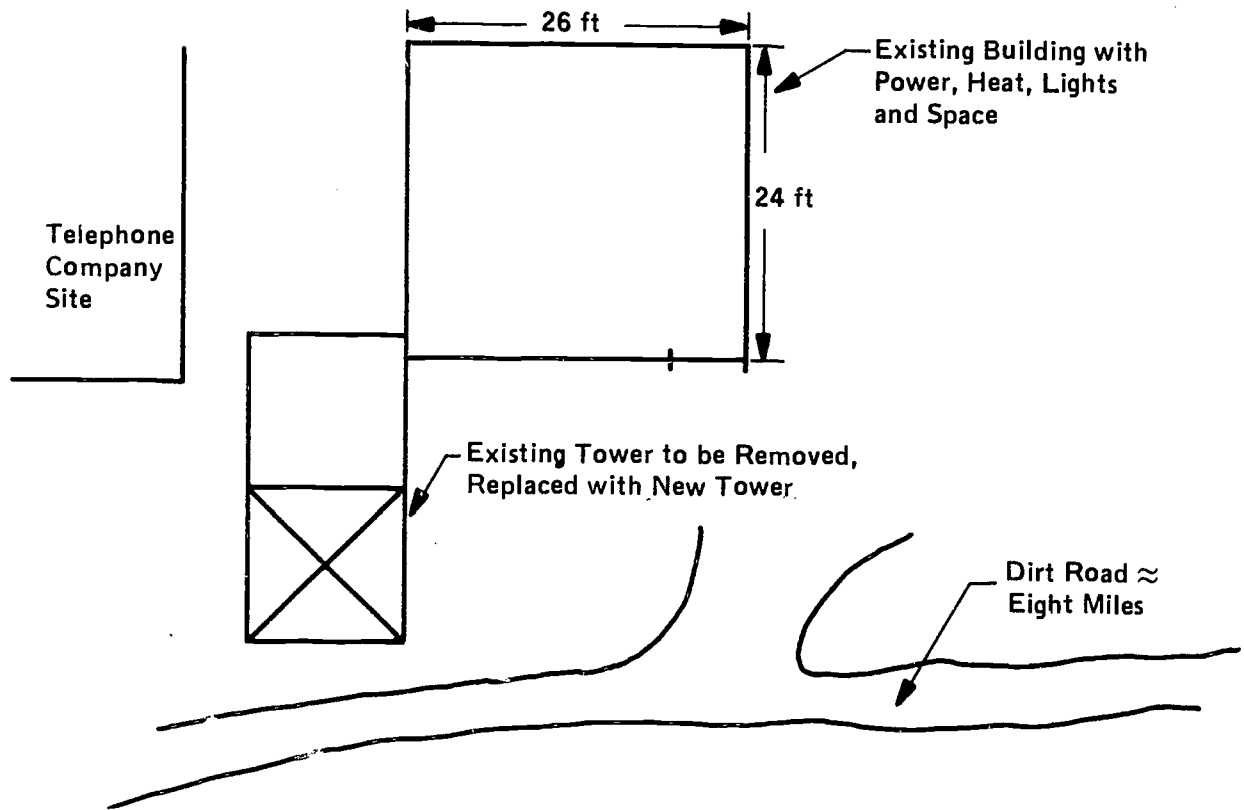

Figure D.3. Existing and Proposed Facilities, Mt. Elden.

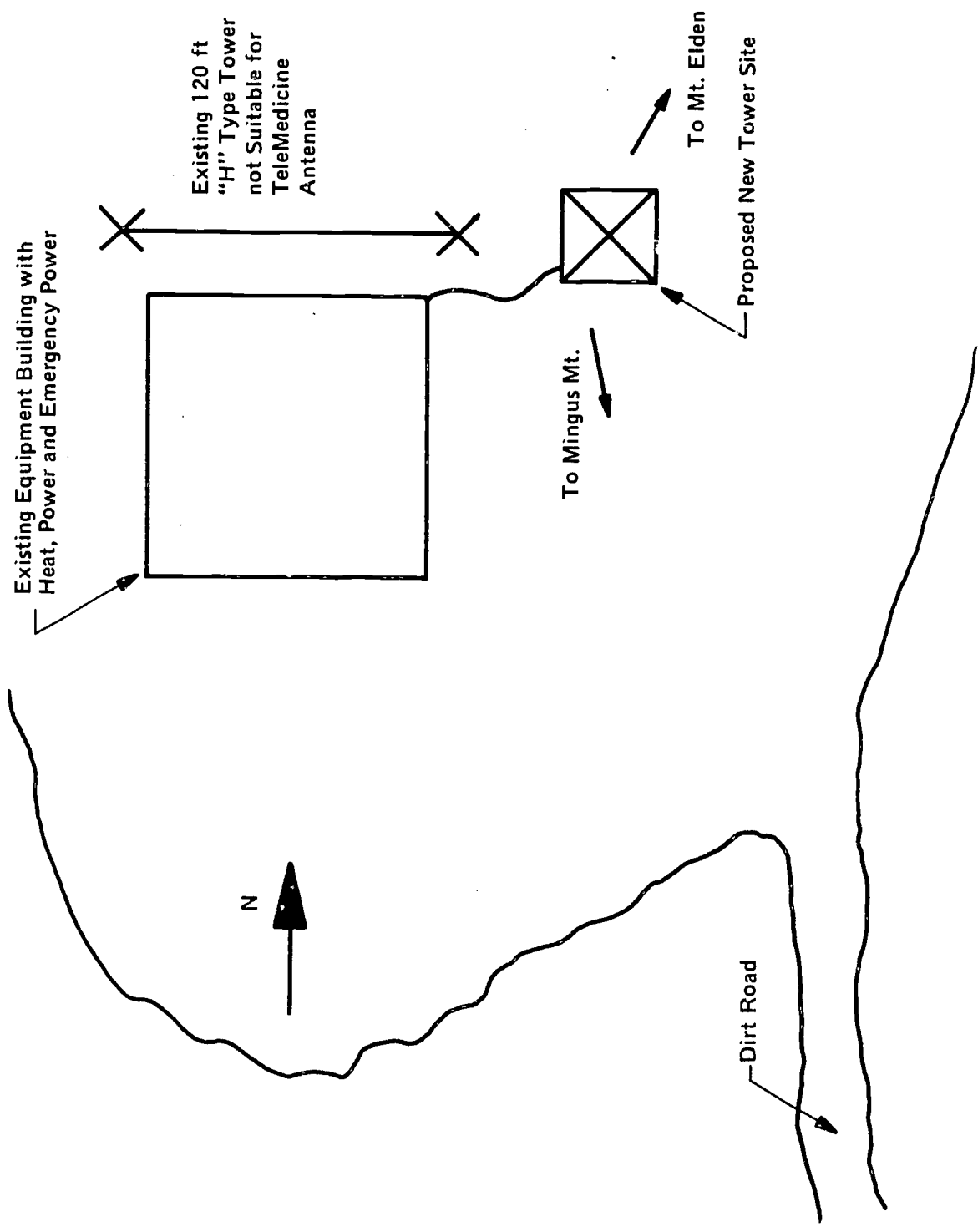

Figure D.4. Existing and Proposed Facilities at Mingus Mountain.

19 in.

VIDEO SWITCHING CONTROL

GRAVEYARD JUNCTION MATRIX

RESET	MT. ELDEN TO PRESTON MESA	TUBA CITY TO PRESTON MESA
RESET	PRESTON MESA TO MT. ELDEN	TUBA CITY TO MT. ELDEN
RESET	PRESTON MESA TO TUBA CITY	MT. ELDEN TO TUBA CITY

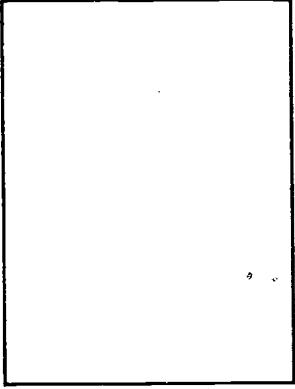
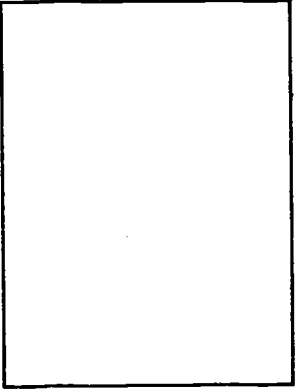

16 in.

48 in.

16 in.

SLOW SCAN TV SWITCHING CONTROL

GRAVEYARD JUNCTION MATRIX

RESET	MT. ELDEN TO PRESTON MESA	TUBA CITY TO PRESTON MESA
RESET	PRESTON MESA TO MT. ELDEN	TUBA CITY TO MT. ELDEN
RESET	PRESTON MESA TO TUBA CITY	MT. ELDEN TO TUBA CITY

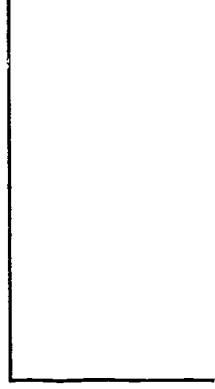
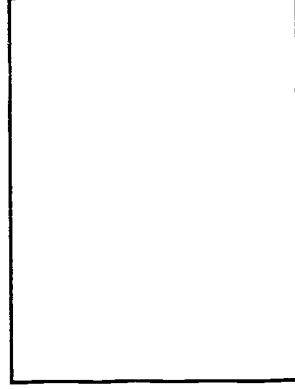

D-7

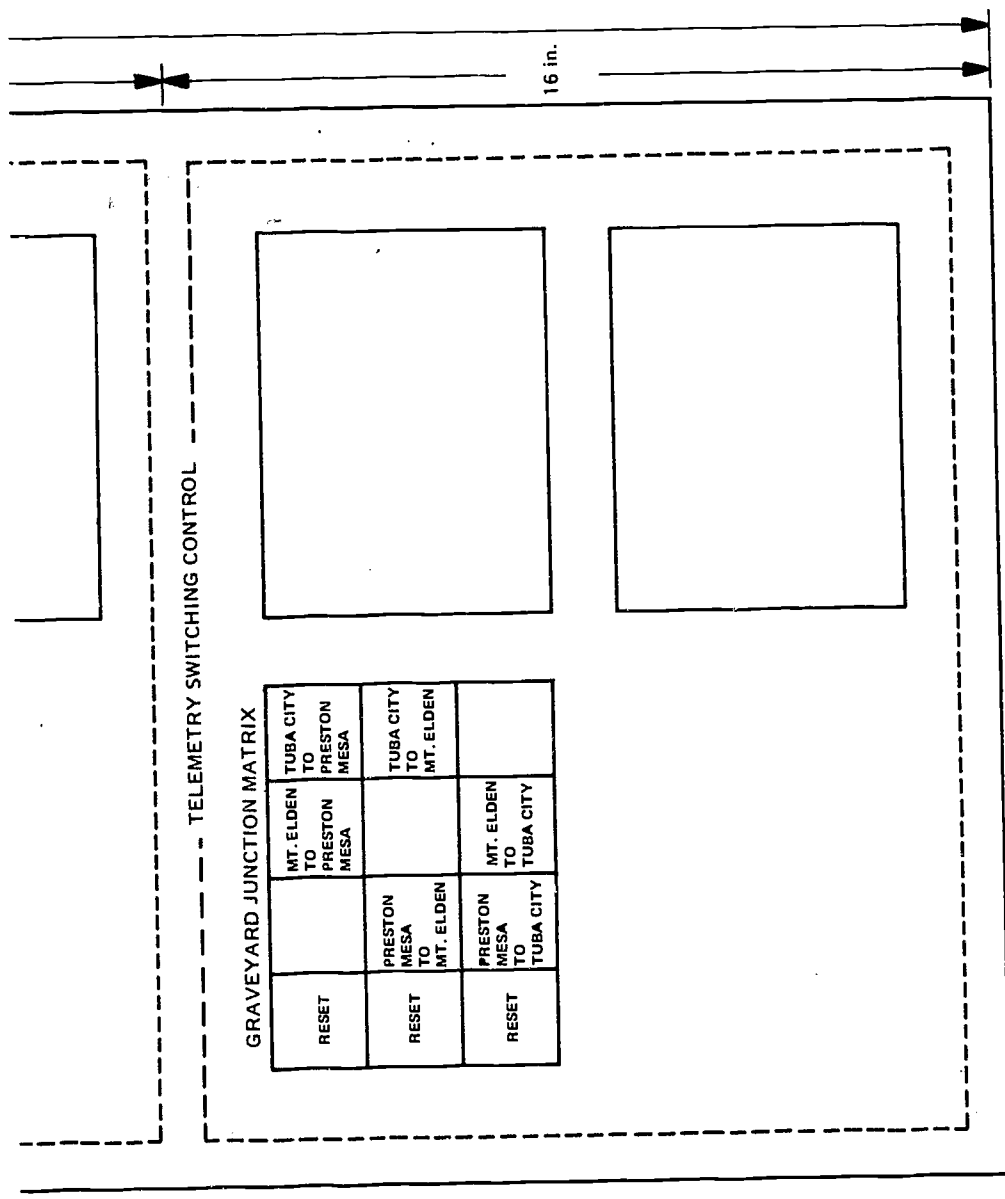
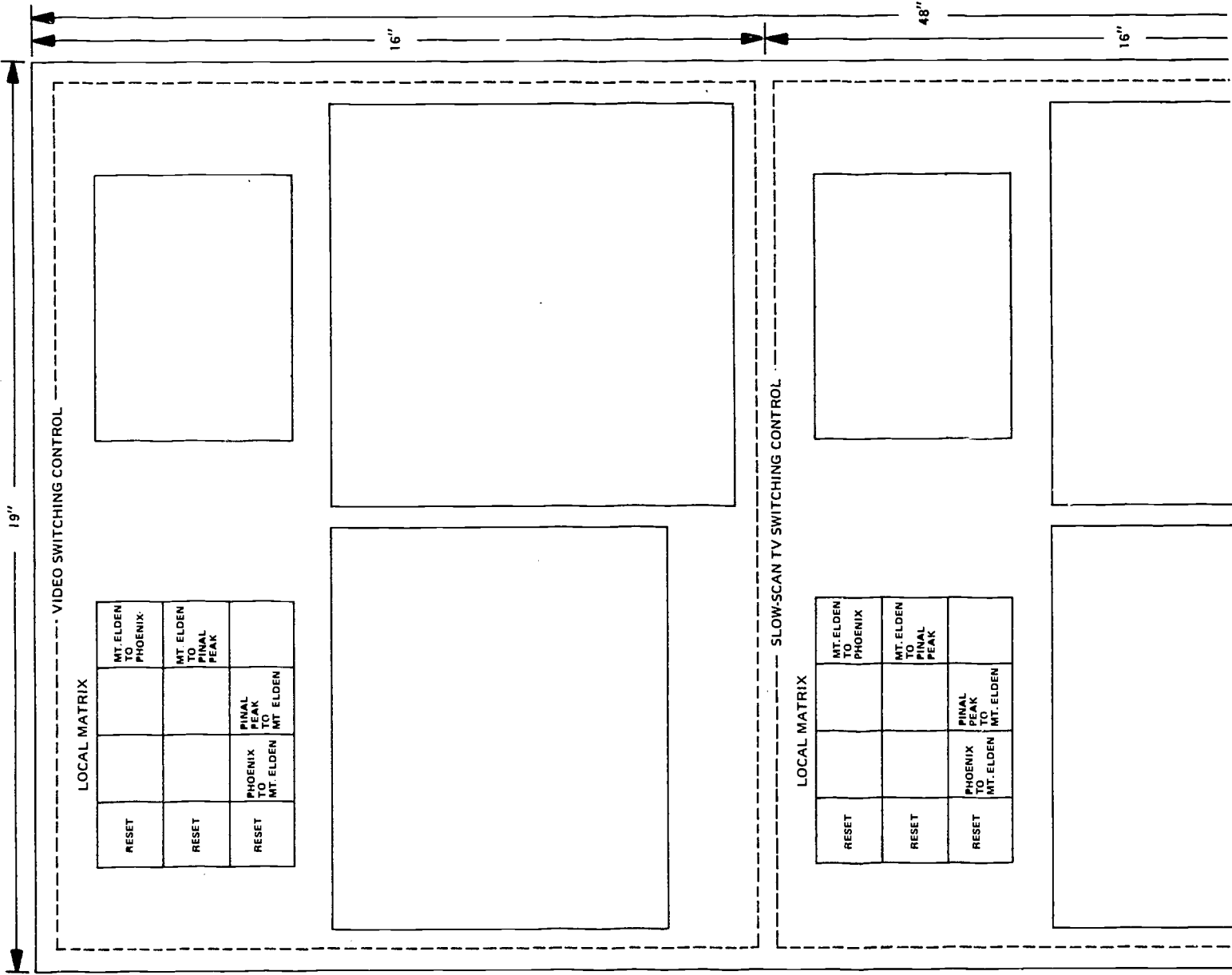
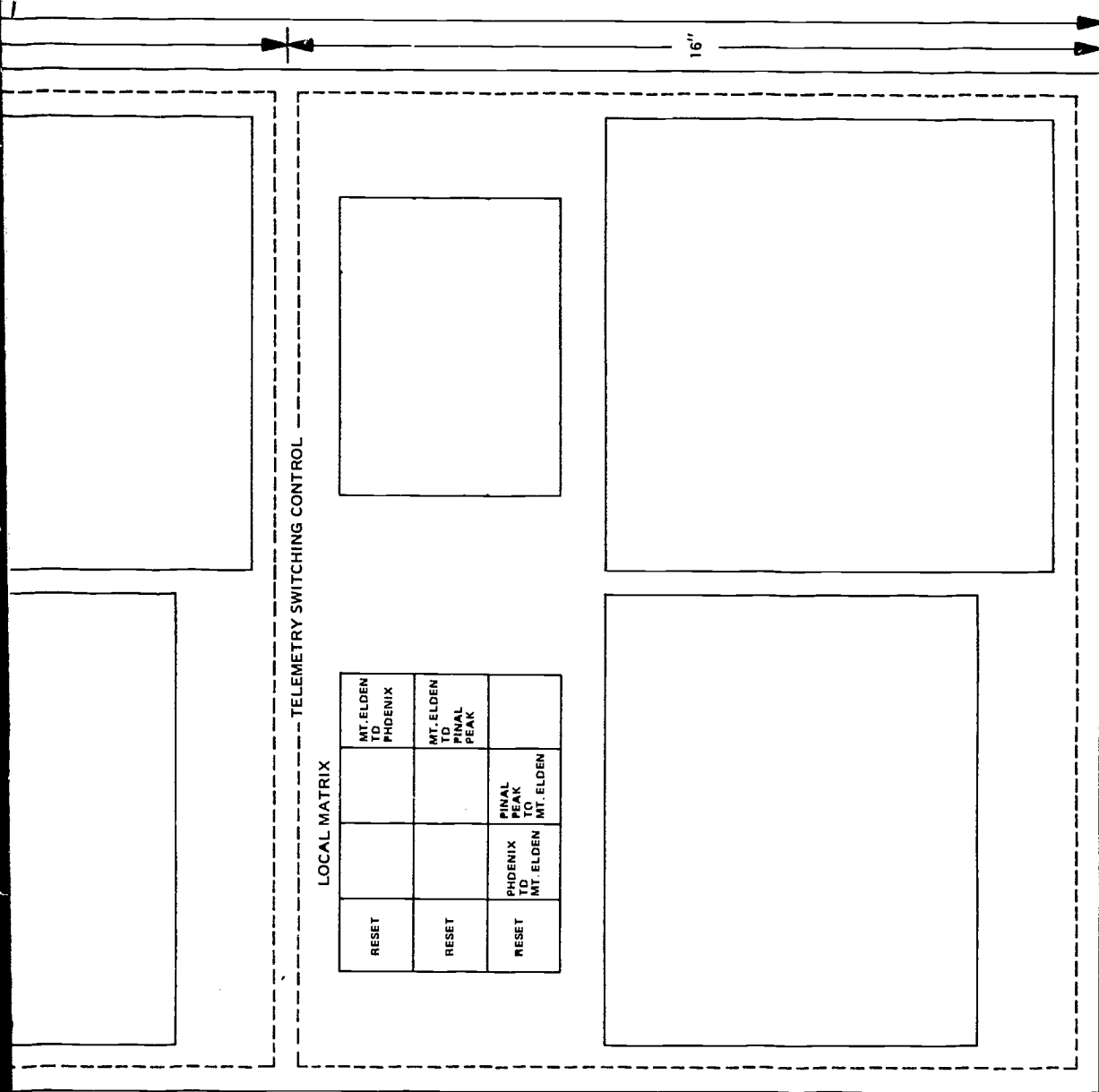

Figure D.6. Switching and Control Panel Layout at Tuba City.



D-9



LOCAL MATRIX

RESET		MT. ELDEN TO PHOENIX
RESET		MT. ELDEN TO RIVAL PEAK
RESET	PHOENIX TO MT. ELDEN	RIVAL PEAK TO MT. ELDEN

TELEMETRY SWITCHING CONTROL

Reserved/Spare

Note: All push button to be rear illuminated type with designations as indicated above engraved thereon. Panel is to be finished in blue. Lettering and dashed lines are to be painted in white. Panel to be hinged at left to swing out for maintenance.

Figure D.7. Switching Control Panel Layout at Phoenix.

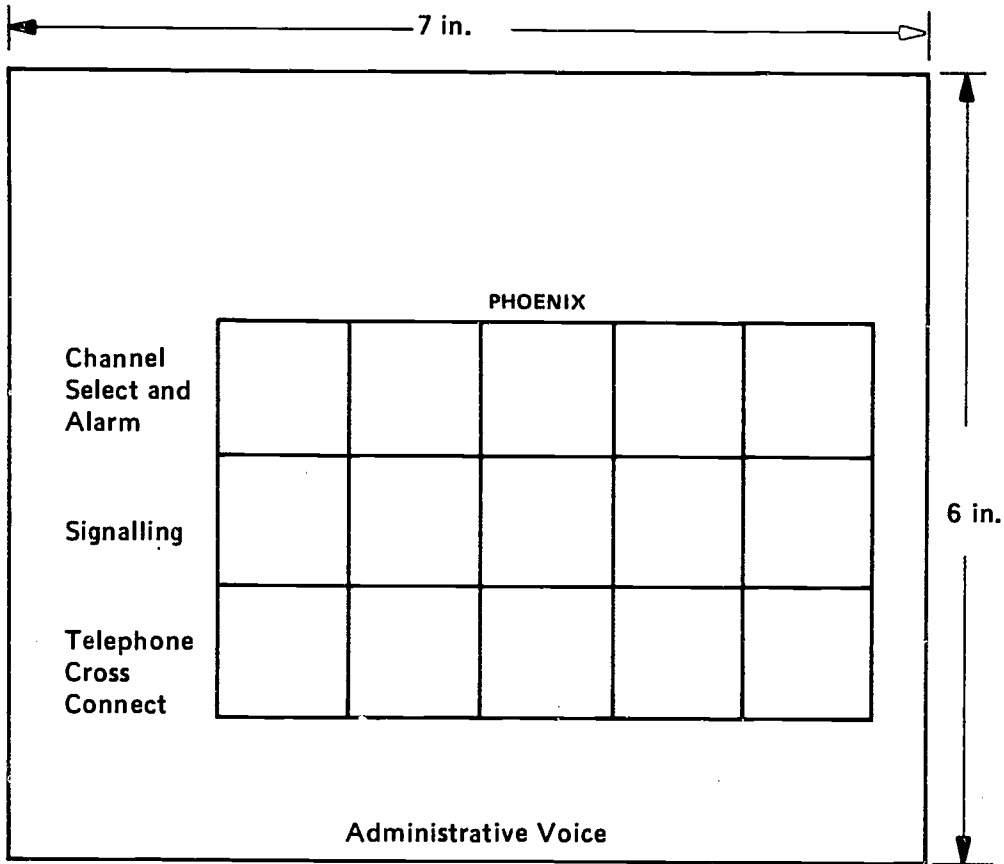

Figure D.8. Administrative Voice Panel at Tuba City.

D-11

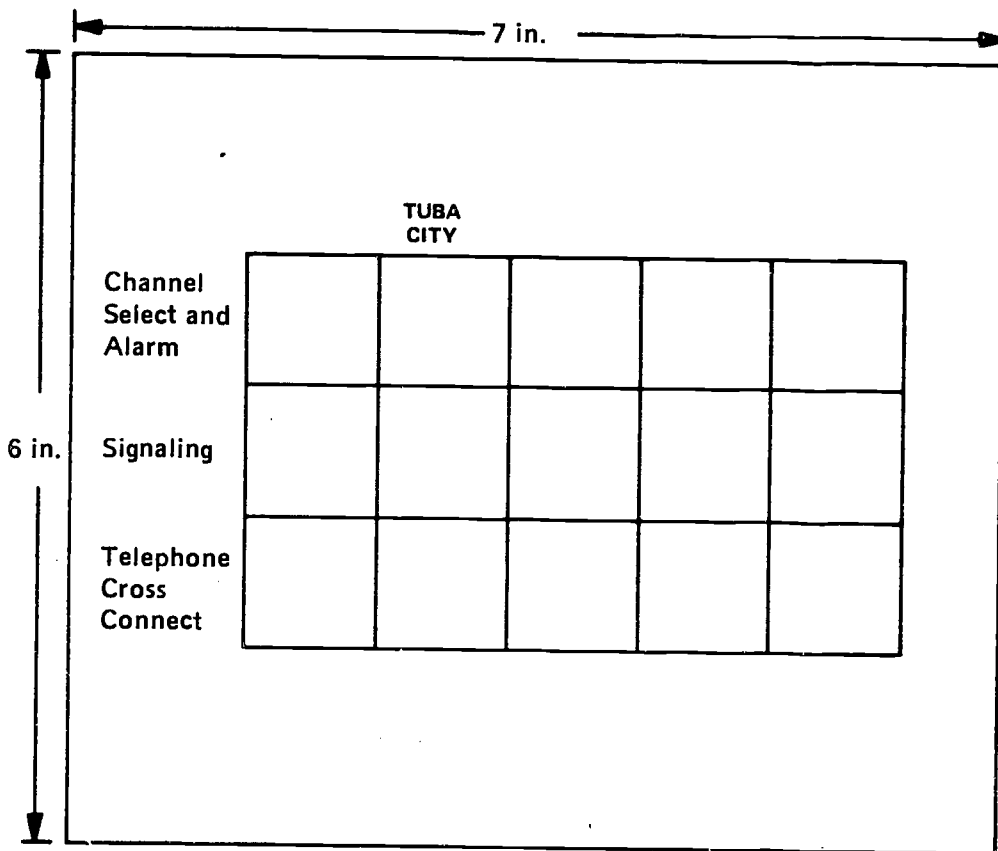

Figure D.9. Administrative Voice Panel of Phoenix.

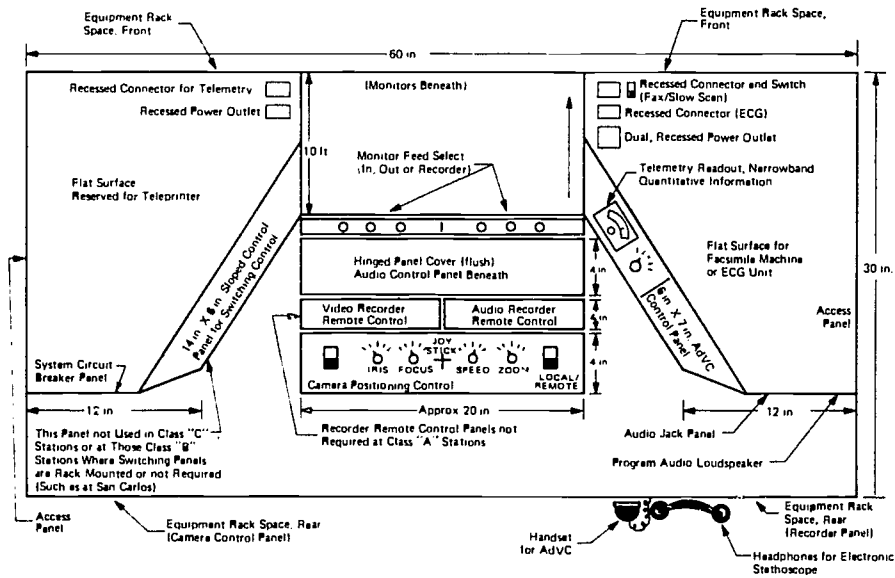
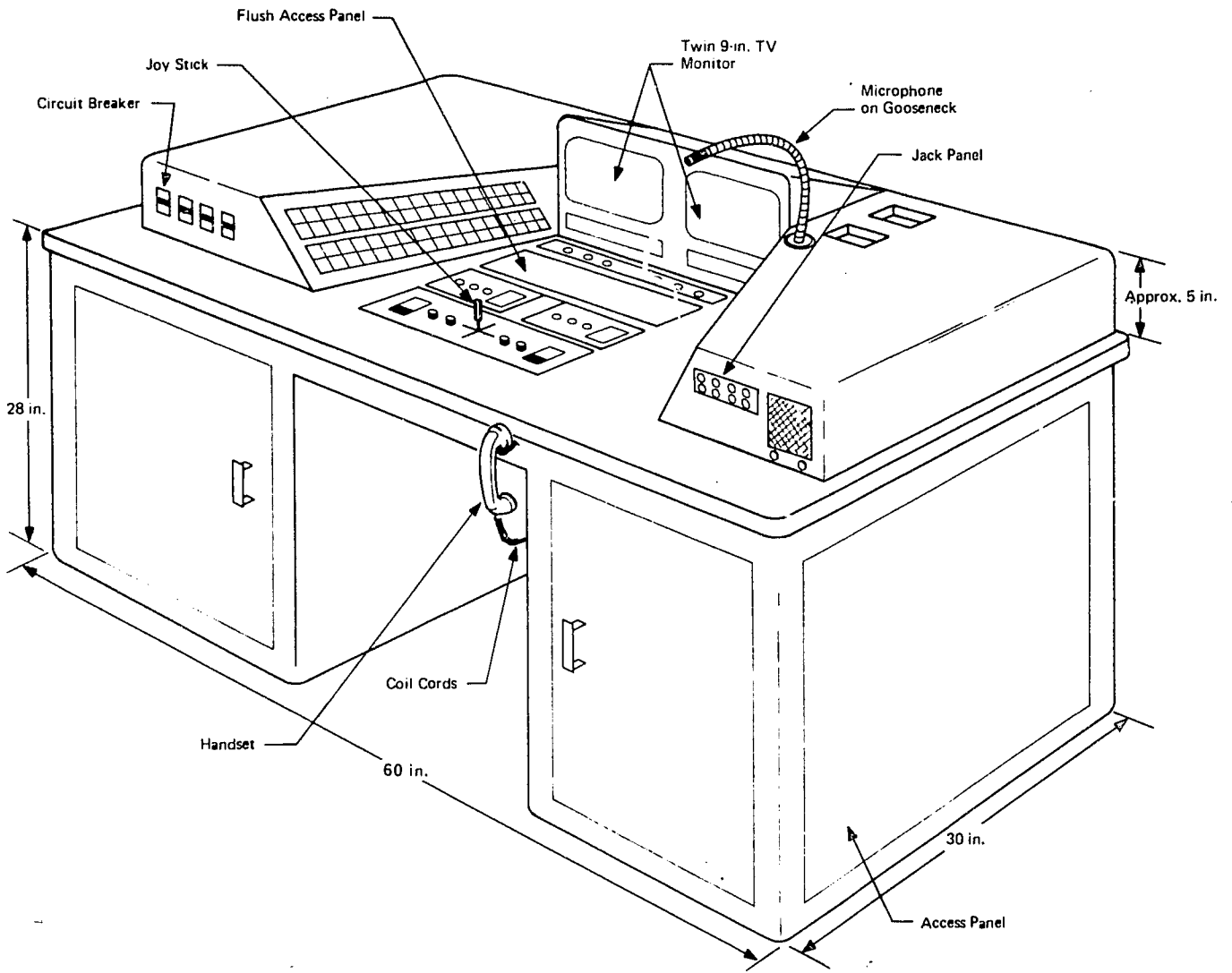

Figure D.10. Typical Control Console, Two Views.

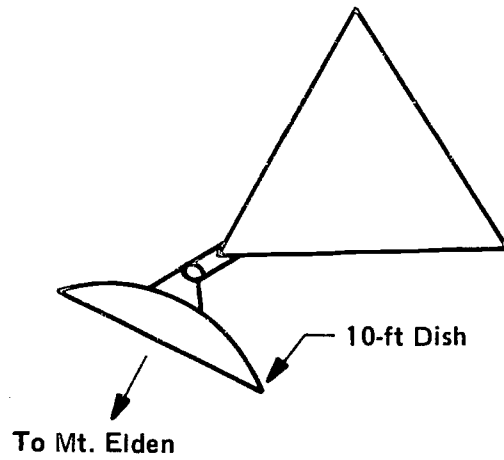
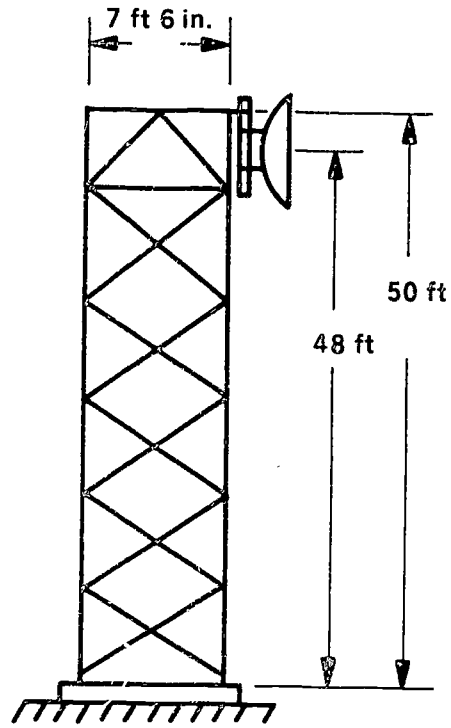

Figure D.11. New Tower and Antenna Arrangement at Graveyard Junction.

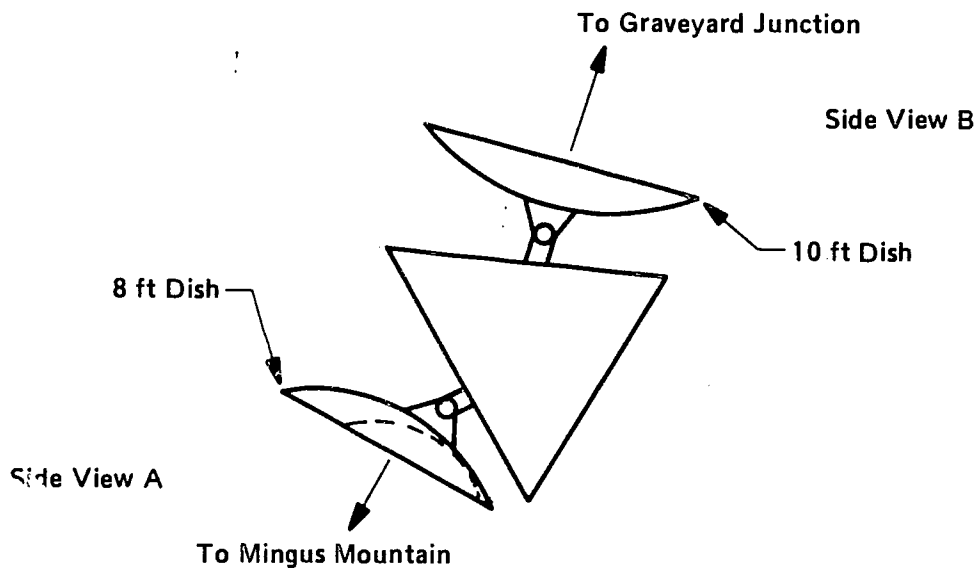
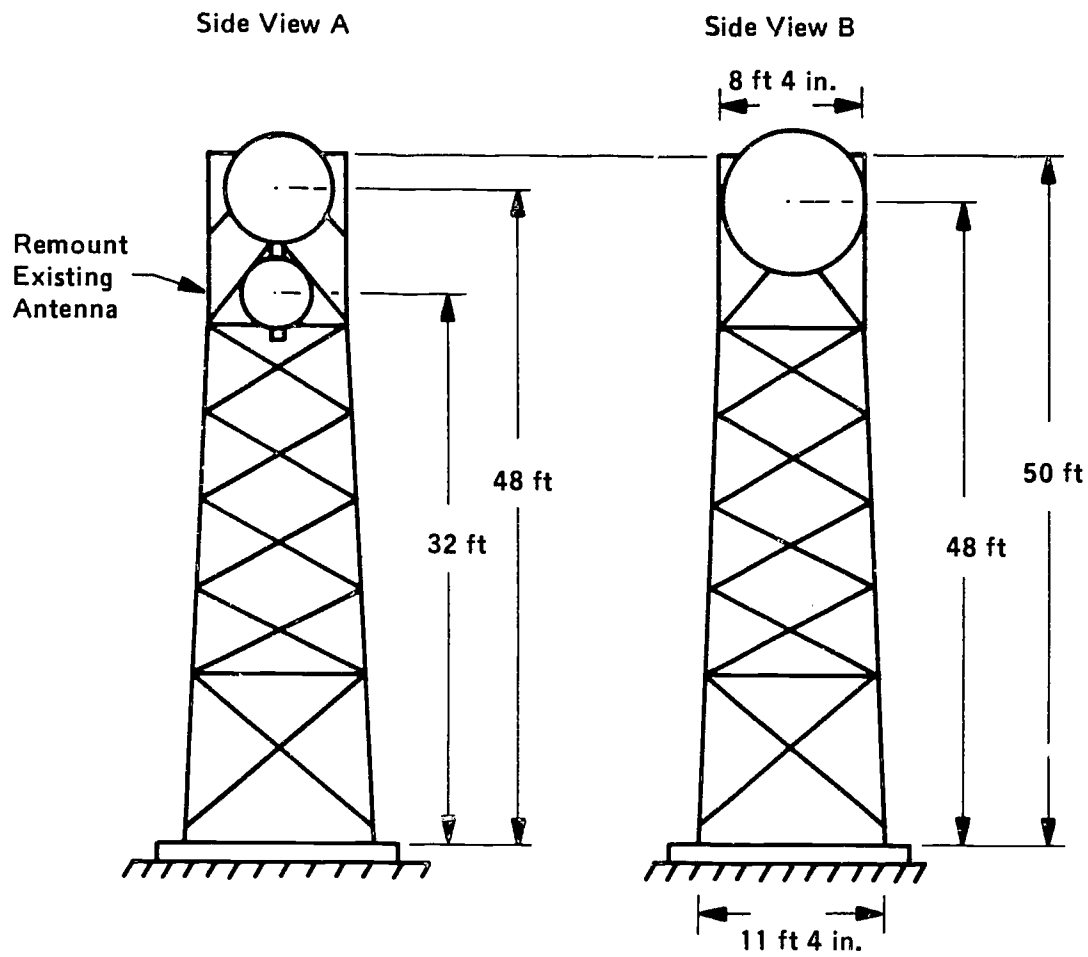

Figure D.12. New Tower Antenna Arrangement of Mt. Elden.

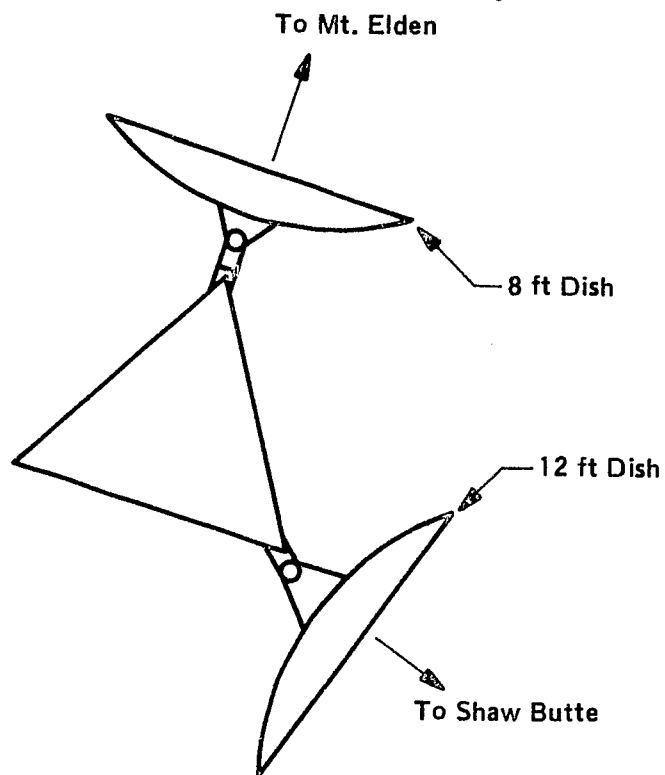
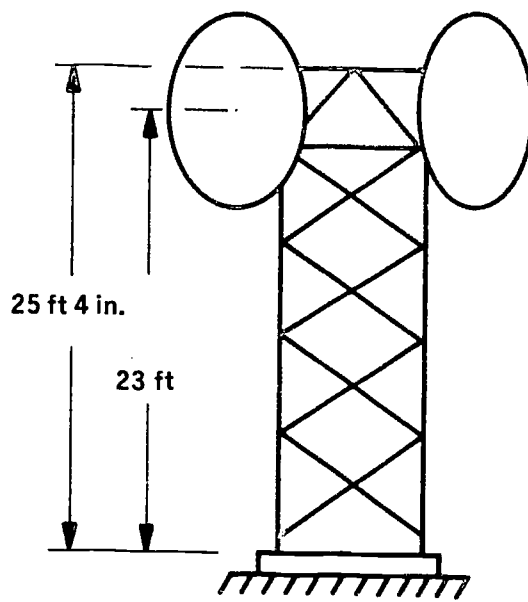

Figure D.13. New Tower and Antenna Arrangement at Mingus Mountain.

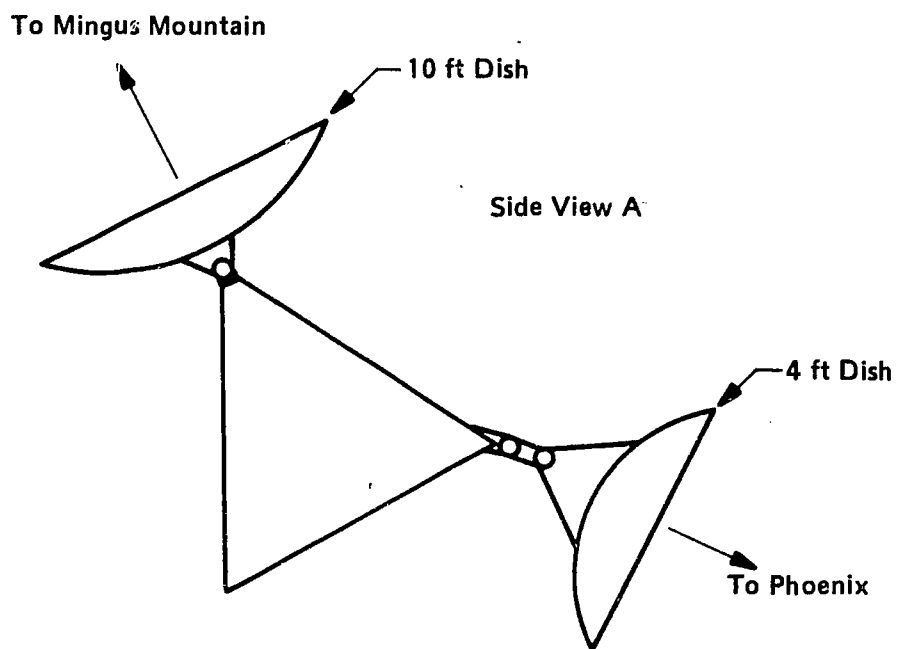
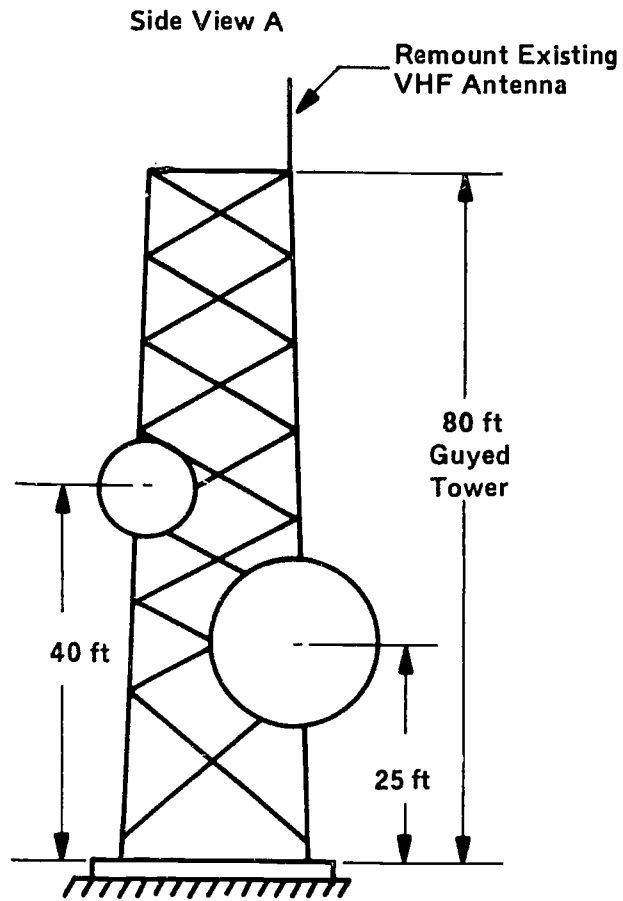

Figure D.14. New Tower and Antenna Arrangement at Shaw Butte.

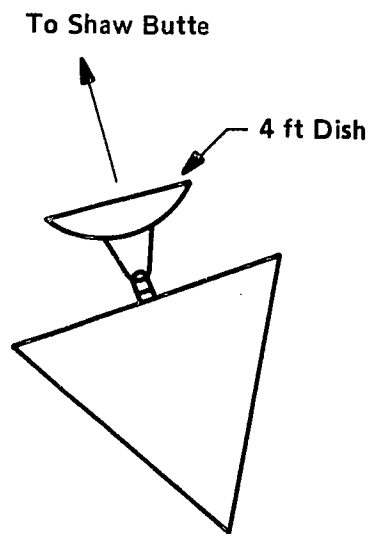
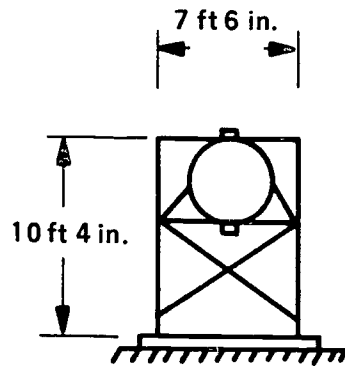
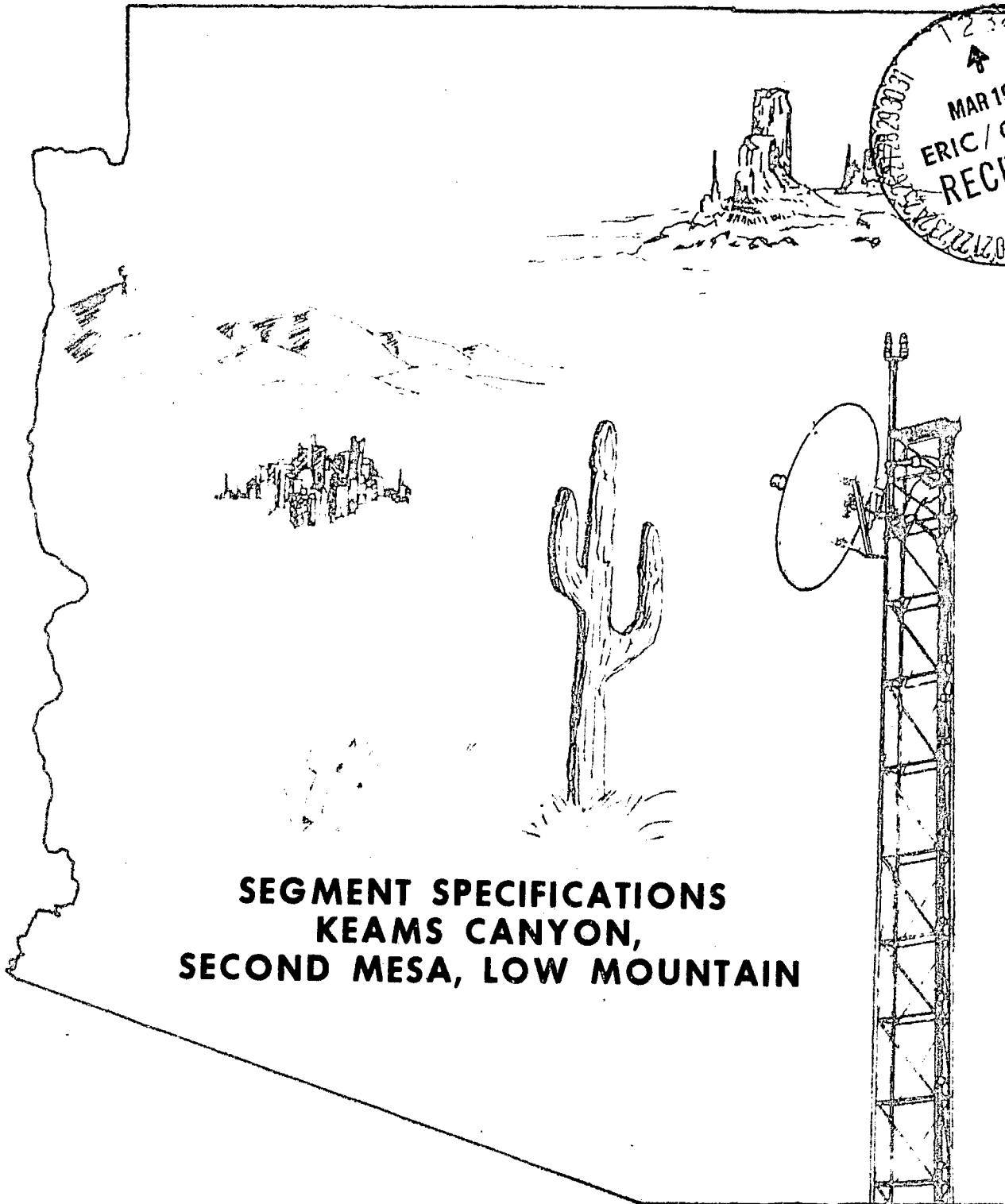

Figure D.15. Support Structure and Antenna Arrangement at Phoenix.

Arizona TeleMedicine Network



**SEGMENT SPECIFICATIONS
KEAMS CANYON,
SECOND MESA, LOW MOUNTAIN**

RC009027

THE ARIZONA TELEMEDICINE NETWORK

SEGMENT SPECIFICATIONS

Keams Canyon

Second Mesa

Low Mountain

Prepared for:

**The University of Arizona College of Medicine
Department of Family and Community Medicine
Tucson, Arizona 85724**

Prepared by:

**The Biomedical and Special Systems Group
Telecommunications Activity
Atlantic Research Corporation
Alexandria, Virginia 22314**

May 30, 1973

TABLE OF CONTENTS

	Page
1.0 SCOPE	1-1
2.0 SYSTEM DESIGN	2-1
2.1 Communications Channels	2-1
2.2 Selection of Microwave Routes	2-2
2.3 Control of Signal Switching	2-4
3.0 APPLICABLE DOCUMENTS	3-1
4.0 SPARE EQUIPMENT AND MATERIALS REQUIREMENT	4-1
APPENDIX A – Path Profiles	
APPENDIX B – Site Maps	
APPENDIX C – Site Photographs	
APPENDIX D – Drawings	

page ii is blank.

1.0 SCOPE

This document defines one segment of the Arizona TeleMedicine Network as referred to in the System Procurement Specifications. All basic requirements shall be as given by the general document as amended by unique requirements for this segment given herein.

The segment defined here is a communication link between the Keams Canyon Hospital, the field health station at Second Mesa and the field health station at Low Mountain, via a switching relay at Keams Canyon. Figure 1.1 illustrates this segment.

This document describes all equipment required to implement the segment and details all allowances to be made to facilitate anticipated expansions to the network.

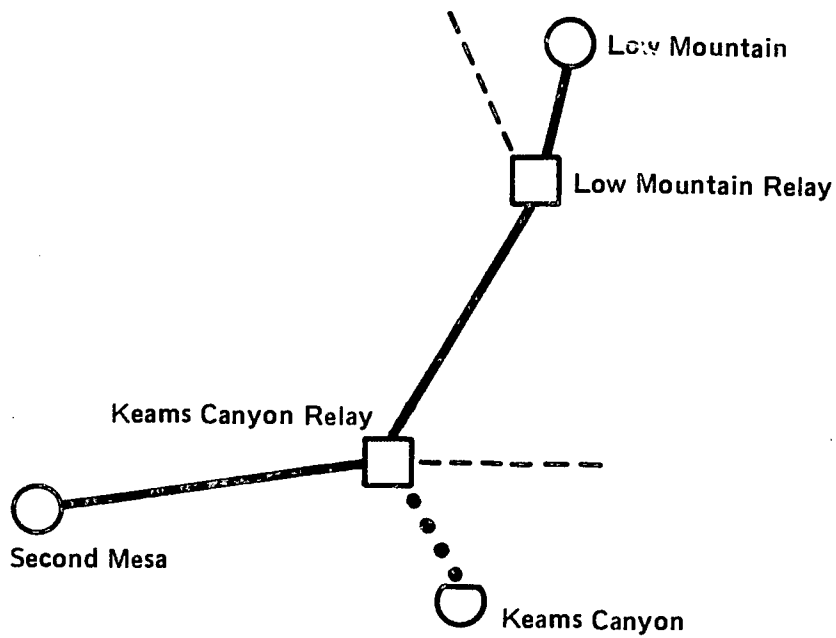
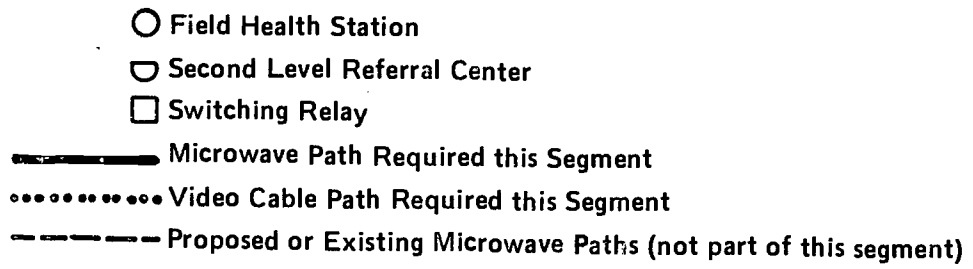

Figure 1.1. Keams Canyon, Second Mesa, Low Mountain Segment.

2.0 SYSTEM DESIGN

2.1 Communications Channels

The full duplex microwave segment shall be channelized to carry the following services:

- Full color television (525 line/30 frame with 5.5 MHz bandpass) – one channel
- Program Audio (15 kHz bandpass) – one channel
- Order wire (with selective signaling) – one channel
- “Voice” slots (FDM, 4 kHz spacing) – up to 12 channels
- Alarm circuits – see channelization plan

A further breakdown of the use of the “voice” slots is included in the suggested spectrum utilization plans for each link within the segment, see Appendix D, 1-3.

The designated voice slots shown are to be used for the following services:

- Camera positioning control (tilt, pan, focus, zoom, iris, mono/color) – six channels (dc control) per voice slot
- Teleprinter/keyboard (300 baud) – six channels per voice slot, one channel per site
- Telemetry (IRIG Standard) dc to 500 Hz – one channel, single voice slot per site
- Slow-scan television (approximately one frame per two-minute interval) – one channel, single voice slot
- Switching control (relay sites, remote) – touch tones, share voice slot
- Administrative Voice Channel(s) – see channelization plan

Locations in the network shall be provided with modems, FSK transmitter/receivers, FM telemetry devices and such required interface equipment so as to facilitate these services at each terminal site.

2.2 Selection of Microwave Routes

The suggested sites for this segment are described as follows. Path profiles, site maps, photographs and drawings are provided in Appendices A, B, C and D, respectively.

Second Mesa

The field health station at Second Mesa is shown in Figure C.7. The equipment for the Arizona TeleMedicine Project will be housed in a separate trailer placed adjacent to the building in order that enclosed access between the two is possible. Figure D.5 details the equipment layout to be installed within the trailer. Backup power for the trailer including microwave equipment is to be furnished as a part of this procurement.

A new tower and antenna are to be installed in accordance with Figures D.4 and D.5.

Keams Canyon Relay

The Keams Canyon Relay site is located on a cliff directly behind the Keams Canyon Hospital. Commercial power is available nearby and is used by existing radio facilities on the cliff. Figure C.1 shows the hospital with the cliff in the background. Figure C.2 shows the approximate location of the new relay station. Existing facilities on the cliff may be seen at the left of C.2. Figure C.3 shows the cliff viewed from the hospital roof with existing facilities clearly visible. Views from the cliff toward the hospital are shown in Figures C.4 and C.5.

A new guyed tower with antennas shall be installed as shown in Figure D.7. An equipment shelter for the microwave and switching equipment shall be provided as shown in Figure D.8. Backup power shall be supplied at the relay site.

Access to the site is by approximately 2 miles of road from the hospital, partly paved and partly dirt.

The particular land to be used must be properly identified and proper land use agreements obtained from the appropriate authorities.

Allowances shall be made in the tower design for at least one additional 6-foot antenna at the 80-foot level of the tower without causing derating of the tower below the basic specifications including wind and ice loading.

Keams Canyon Hospital

The Keams Canyon Hospital is to be connected to the Keams Canyon Switching Relay by a duplex broadband equalized cable. This cable shall be such that the entire baseband can be transmitted and meet full specifications as if it were a microwave link in the system. Figure D.8 shows the proposed routing of the cable. It is intended to carry the cable by direct attachment to a steel messenger cable from the cliff to the hospital penthouse and thence through conduit to the TeleMedicine room. Figure C.6 shows the interior of the conference room at the hospital where the terminal equipment shall be located. Figure D.9 is the proposed equipment layout for this room.

Low Mountain Relay

The Low Mountain Relay site is undeveloped at present. A new tower, antenna and shelter as well as both primary and backup power supplies are required. The antenna and tower arrangements are shown in Figure D.12. Figure D.13 is a generalized site plan which may require rearrangement to fit local conditions.

The particular land to be used must be properly identified and land use agreements obtained from the appropriate authorities.

Low Mountain

The field health station at Low Mountain is shown in Figure C.8. The equipment for the Arizona TeleMedicine Project will be housed in a separate trailer adjacent to the existing trailer in such a manner that enclosed access between the two is possible. Figure D.14 is a plan of the present clinic at Low Mountain. Figure D.15 shows the equipment layout to be used for the new equipment.

A new antenna and tower shall be installed in accordance with Figures D.15 and D.17. Backup power must be provided for the trailer and microwave equipment.

2.3 Control of Signal Switching

In this segment of the Arizona TeleMedicine Network, the following control and switching relationships shall prevail:

Switching Relay	Control Station
Keams Canyon	Keams Canyon Hospital

Refer to the System Procurement Specifications document for a general discussion of switching concepts.

The switch configuration for Keams Canyon Relay is discussed in the following paragraph. Note that blank panel or space is to be provided for switching functions which will be added as the network expands. However, if a portion of a switch matrix is to be used in this segment, the entire matrix shall be installed. Only the switch positions specifically called out in this segment are to be wired.

Keams Canyon Hospital, a Class "b" station, will have installed as an integral part of its control panel, a group of illuminated push buttons which control the station's switching tones. These tones will be generated by oscillator modules that produce the dual frequency notes commonly called "touch tones." Depending on which tones are generated and transmitted to the switch point a particular cross point on a matrix located at the switching relay station will be energized.

At the Keams Canyon Relay Switch Point (a Class "R1" station) three transmit/receive (T/R) pairs¹ are brought together for switching. They are as follows:

¹One additional T/R pair will be added as the network expands. Make allowance for rack space and power requirements.

Keams Canyon Hospital: This T/R pair links the hospital at Keams Canyon to the Keams Canyon switchpoint via a direct cable link.

Second Mesa Clinic: This T/R pair links the field health station at Second Mesa to the Keams Canyon switch point via a direct microwave path.

Low Mountain Clinic: This T/R pair links the field health station at Low Mountain to the Keams Canyon switch point via Low Mountain relay site.

The switch tones are transmitted from the Keams Canyon Hospital to the switch point via the Keams Canyon to Second Mesa administrative voice channel.

In general each transmit and receive circuit of the duplex link is switched independently. The various switch configurations possible are shown in the Switch and Control panel drawing, Figure D.10.

3.0

APPLICABLE DOCUMENTS

The Arizona TeleMedicine Network,
System Procurement Specifications, May 1973

3-1

59

page 2-4 is blank.

4.0

SPARE EQUIPMENT AND MATERIALS REQUIREMENT

The Contractor shall, as part of this construction contract, supply the following list of spare parts, components, panels, equipment and material. Delivery shall be to the site as stipulated by the Project Director. Delivery shall be effected prior to final acceptance.

2 sets	Matched 1-inch camera tube replacements
1 each	Color monitor (type as supplied at each site)
1 each	Monochrome monitor, large (type as supplied at each site)
1 each	Twin small monochrome monitors (type as supplied in each console)
1 each	Audio logging recorder (type as supplied in each console)
1 each	Video logging recorder (type as supplied in each console)
2 each	Video DA modules (type as supplied in each console)
2 each	Video DA power supply (type as supplied in each console)
1 each	Audio mixer and limiter (type as supplied in each console)
1 set	Modules for multiplex equipment (12 channels)
1 set	Common equipment modules, panels and circuit boards (not channel dependent) for microwave radio equipment for both 6 GHz and 12 GHz units
4 each	Video switcher modules
4 each	Audio frequency switcher modules
1 set	Telemetry equipment modules
4 boxes	Fuses of all types

page 3-2 is blank

APPENDIX A

PATH PROFILE

Note: When towers are not specified on the Vertical Earth Profiles, only minimum tower heights governed by antenna size, will be required.

Note: Corrections for earth curvature and Fresnel zone radius have been included on each profile:

Δ 0.3 first Fresnel zone radius

Δ earth curvature for $k = 2/3$

page 4-2 is blank

A-1

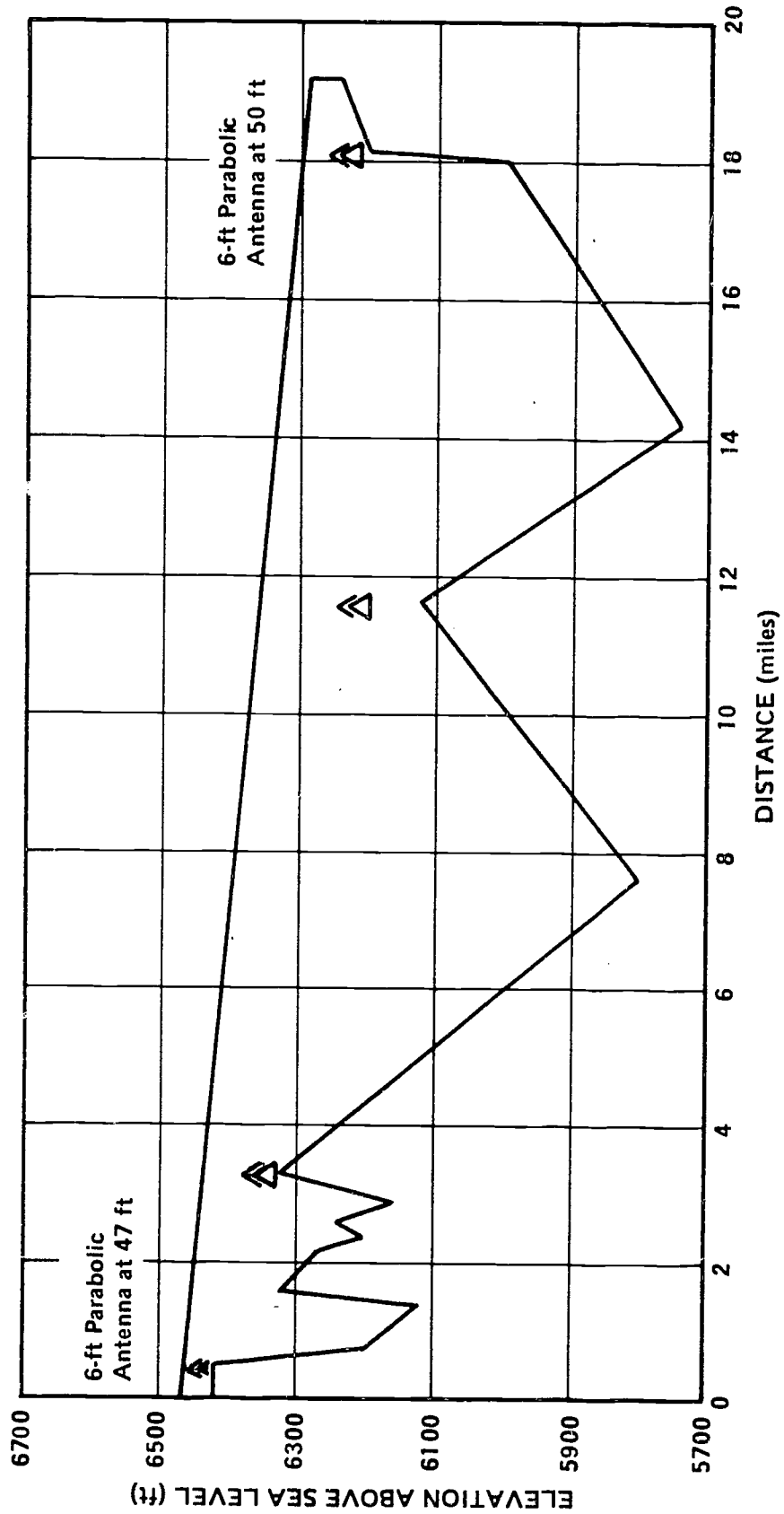

Figure A.1. Vertical Earth Profile, Keams Canyon to Second Mesa.

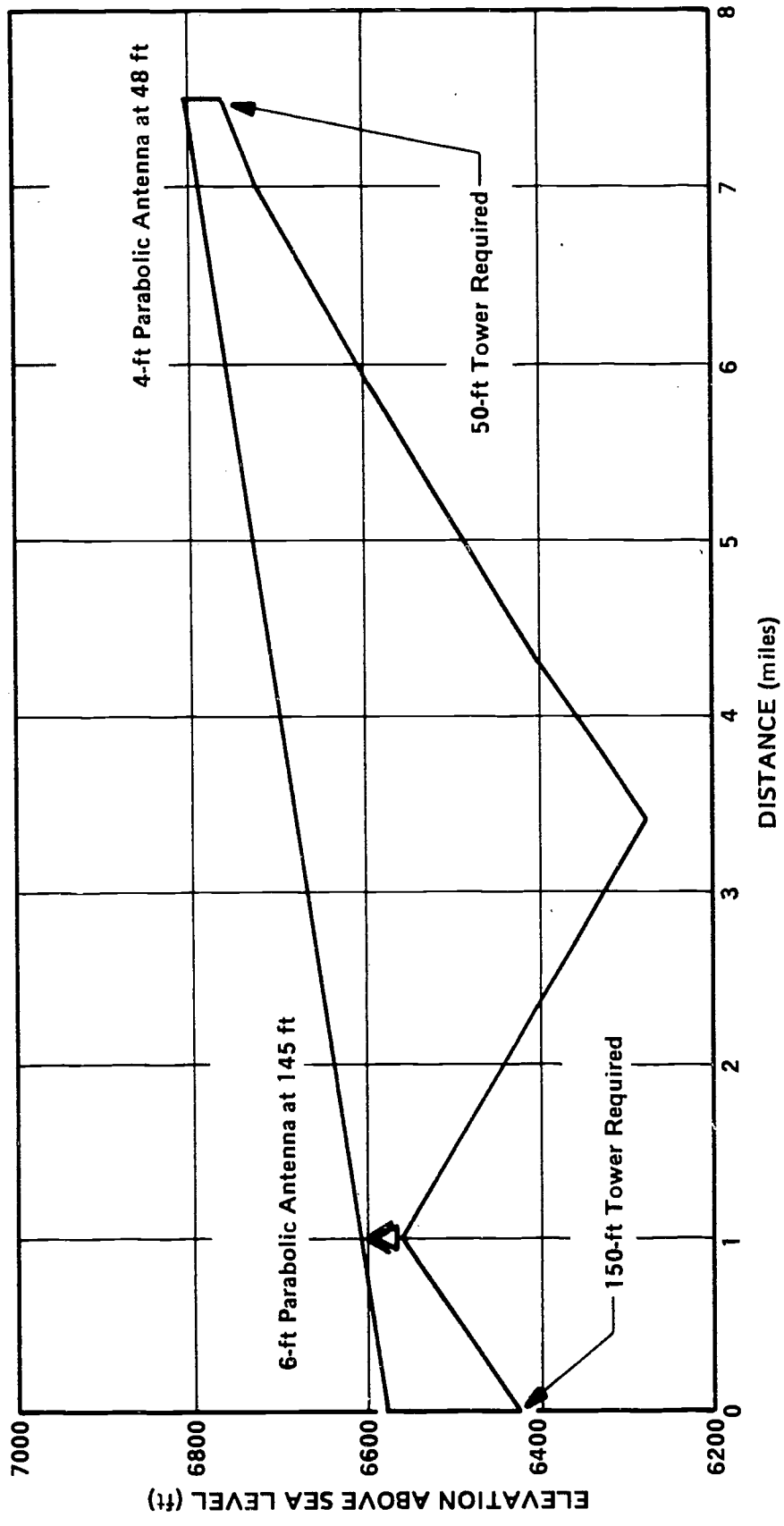

Figure A.2. Microwave Path Profile, Keams Canyon Relay to Low Mountain Relay.

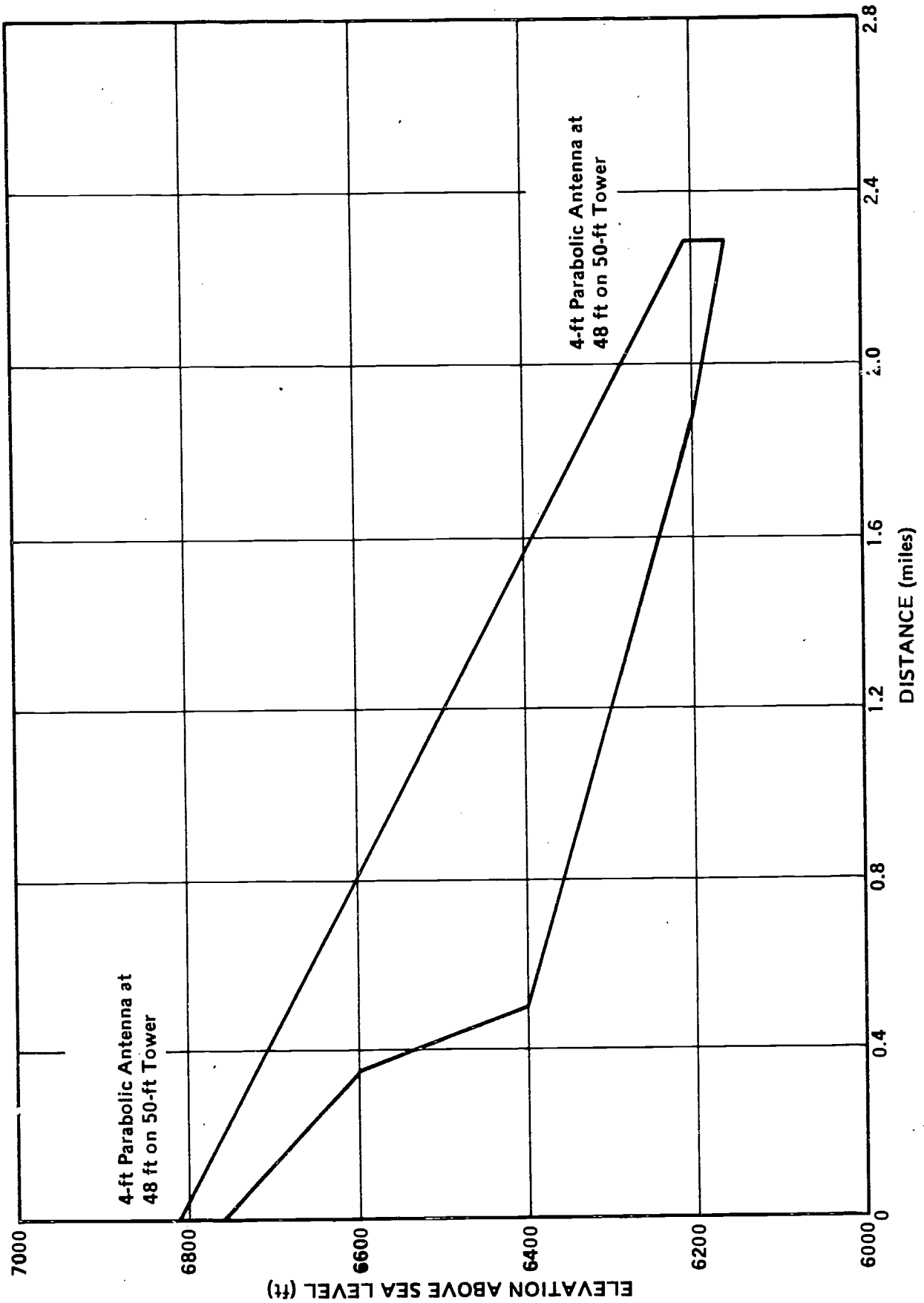

Figure A.3. Microwave Path Profile, Low Mountain Relay to Low Mountain Clinic.

APPENDIX B

SITE MAPS

B-1

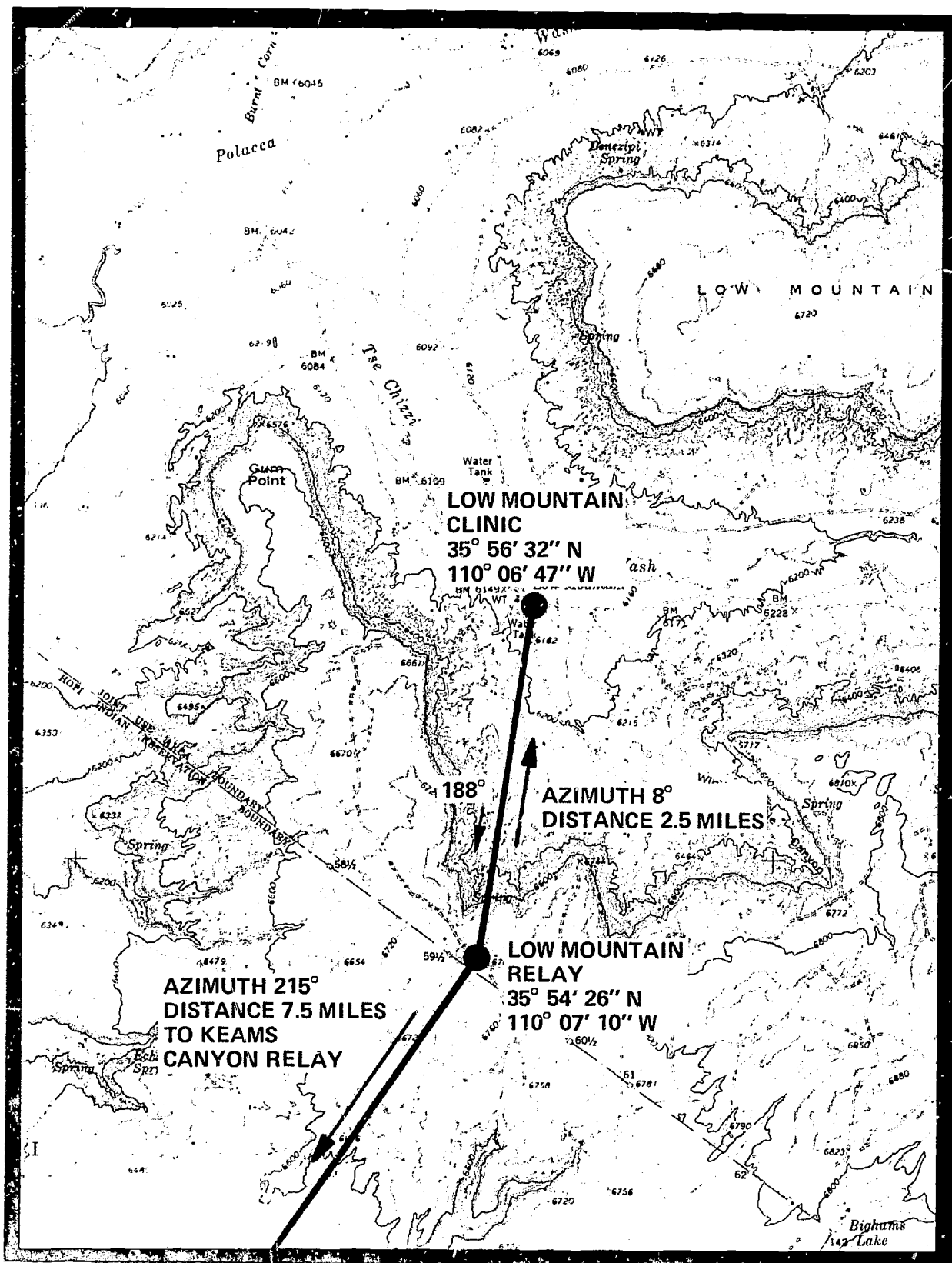

Figure B.3. Site Map Showing Low Mountain Clinic and Low Mountain Relay.

APPENDIX C

SITE PHOTOGRAPHS

C-1

69

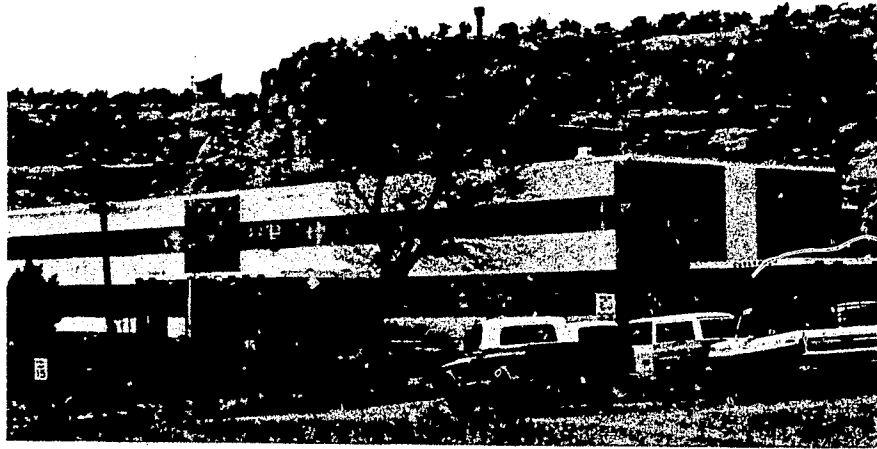

Figure C.1. Keams Canyon Hospital Viewed from the Southeast with Cliff in Background.

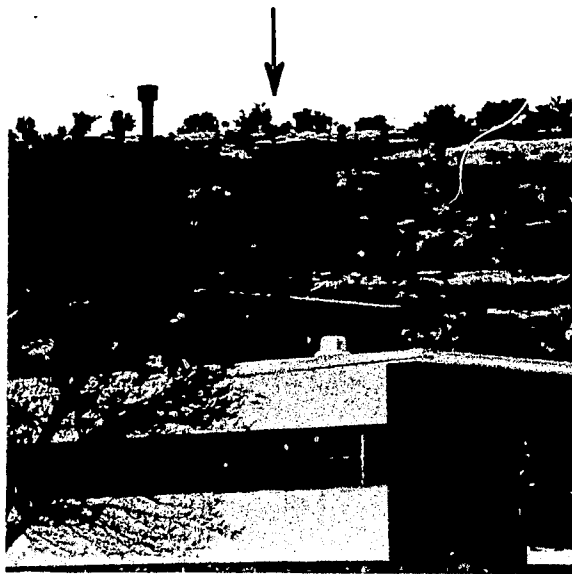

Figure C.2 View Toward Proposed New Relay Site on Cliff Behind Keams Canyon Hospital.



Figure C.3. View from Keams Canyon Hospital Roof Showing Existing Radio Facility on Cliff.



Figure C.4. View from Cliff Showing Penthouse of Keams Canyon Hospital.



Figure C.5. View Toward Keams Canyon Hospital from Vicinity of Proposed New Relay Site.



Figure C.6. View of Interior of Keams Canyon Hospital Conference Room.

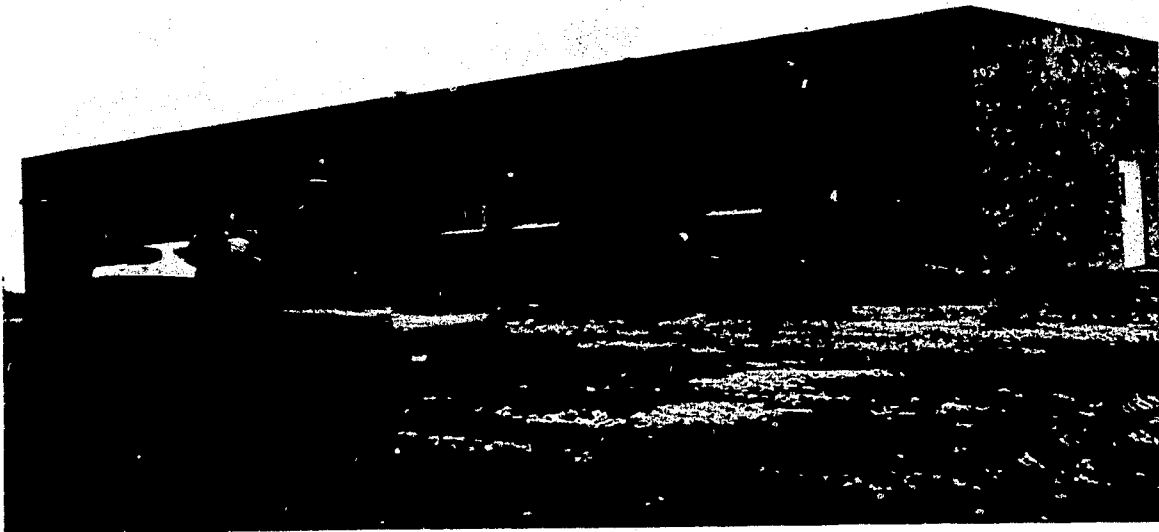

Figure C.7. View of Field Health Station at Second Mesa.

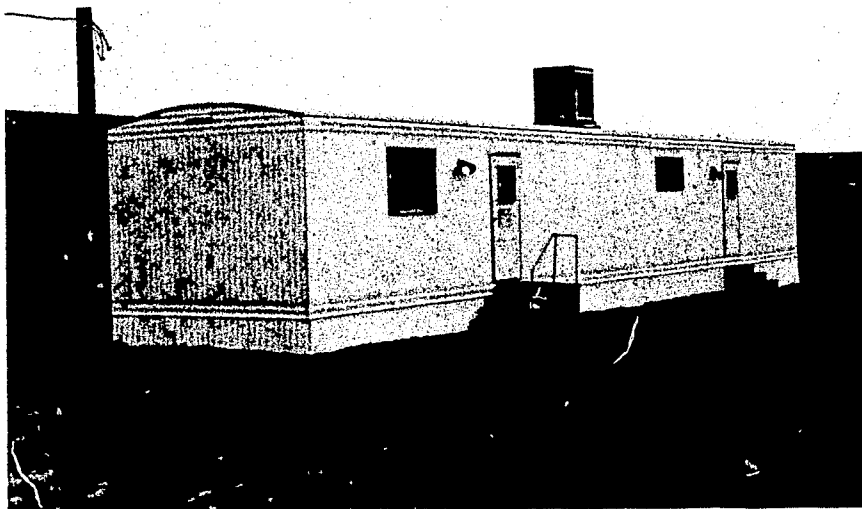

Figure C.8. View of Field Health Station at Low Mountain.



Figure C.9. View Toward Low Mountain Relay Site from Low Mountain Clinic.

APPENDIX D

DRAWINGS

D-1

75

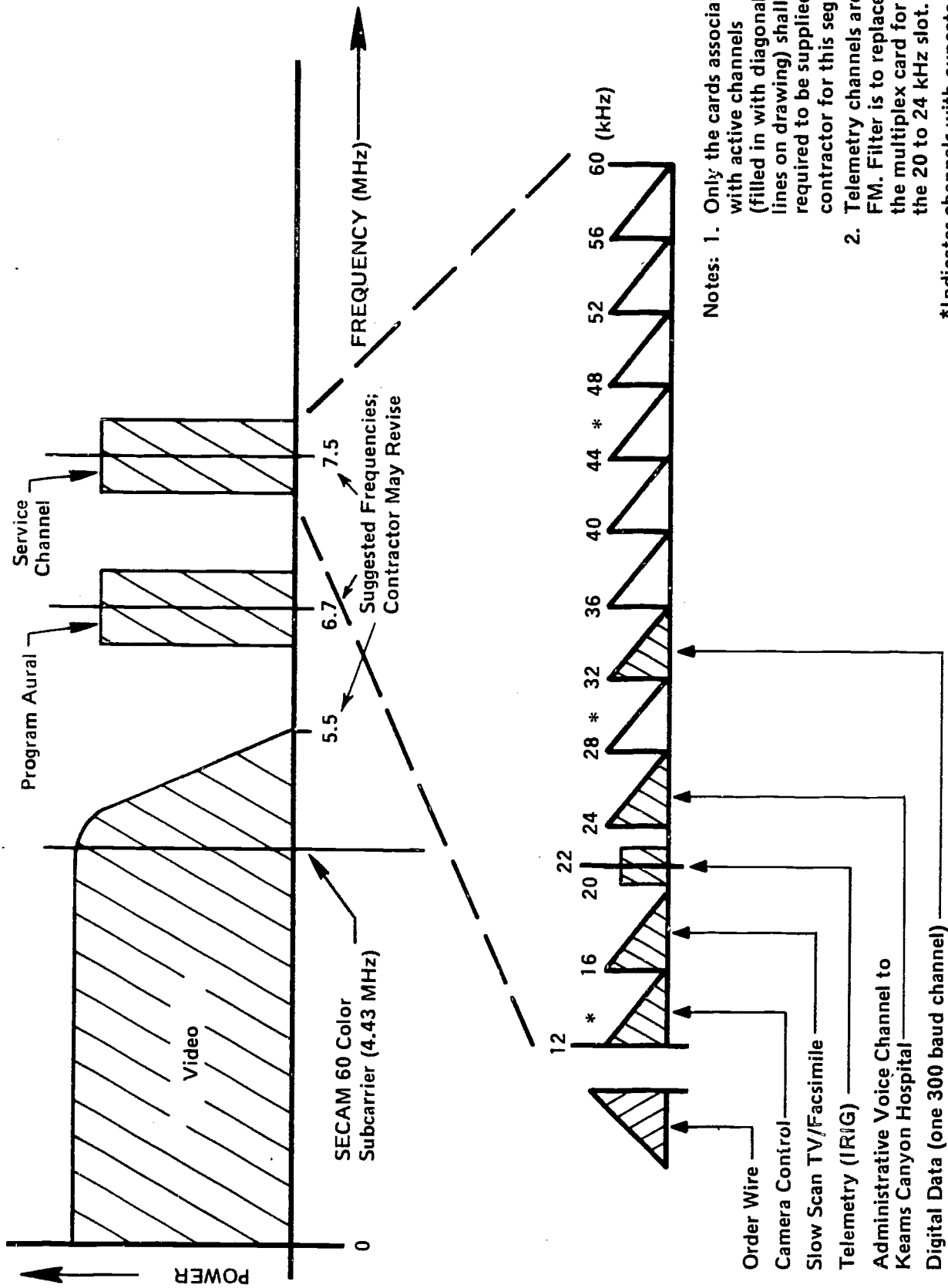

- Notes:
1. Only the cards associated with active channels (filled in with diagonal lines on drawing) shall be required to be supplied by contractor for this segment.
 2. Telemetry channels are FM. Filter is to replace the multiplex card for the 20 to 24 kHz slot.
- *Indicates channels with expected high noise level.

Figure D.1. Channelization Plan, Link from Second Mesa to Keams Canyon Relay.

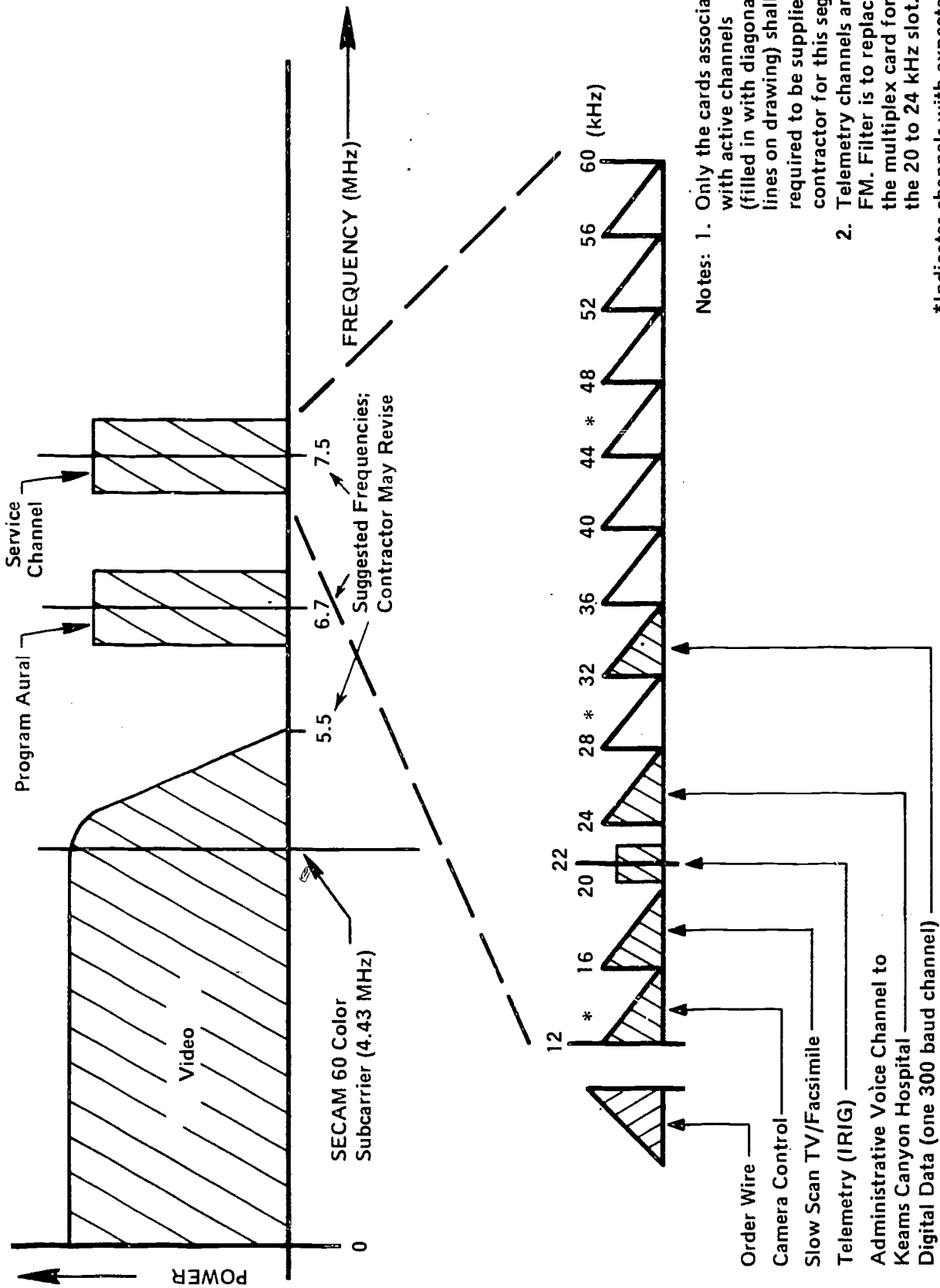
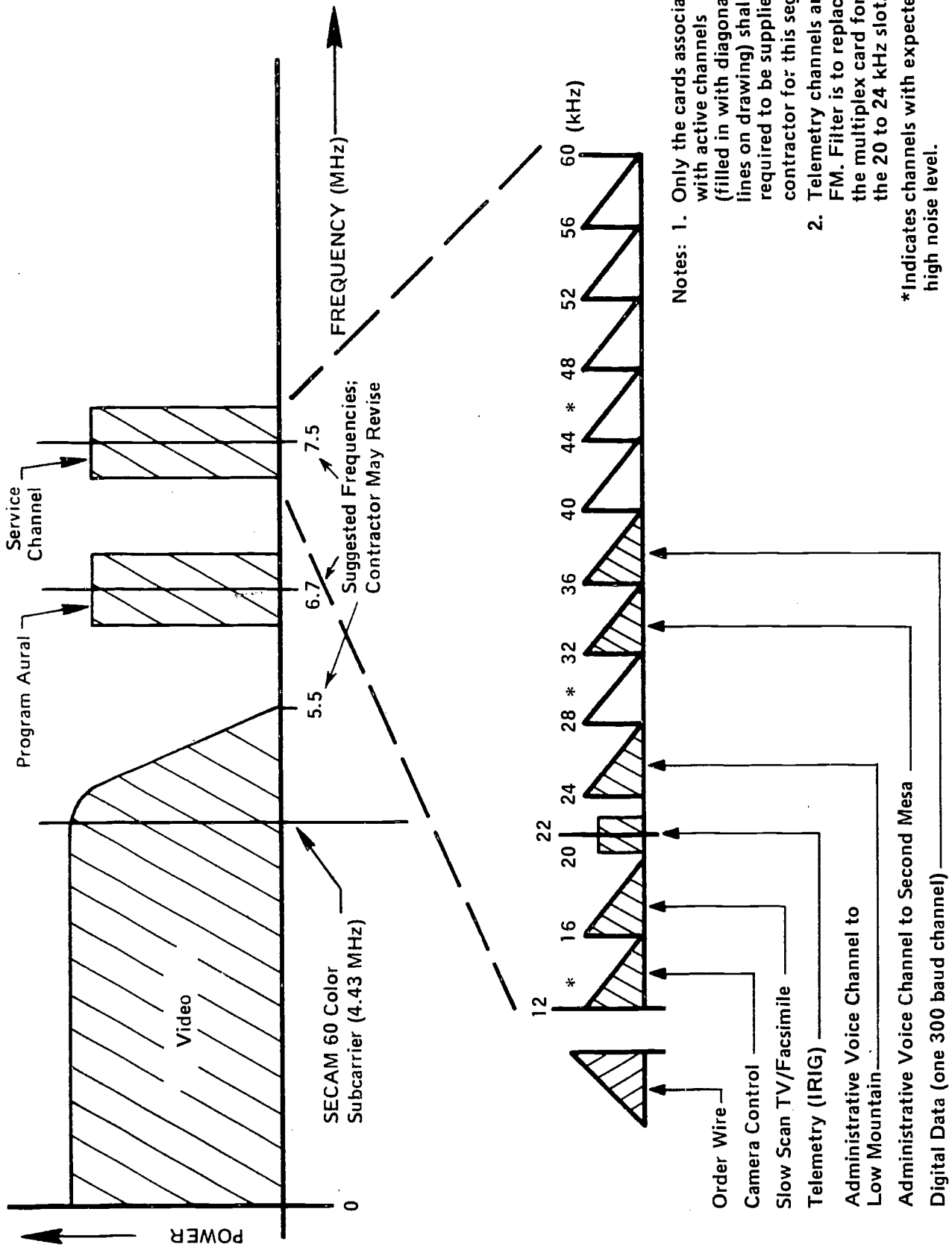

Figure D.2. Channelization Plan, Link from Low Mountain to Keams Canyon Relay.



- Notes:
1. Only the cards associated with active channels (filled in with diagonal lines on drawing) shall be required to be supplied by contractor for this segment.
 2. Telemetry channels are FM. Filter is to replace the multiplex card for the 20 to 24 kHz slot.
- *Indicates channels with expected high noise level.

Figure D.3. Channelization Plan, Link from Keams Canyon Hospital to Keams Canyon Relay.



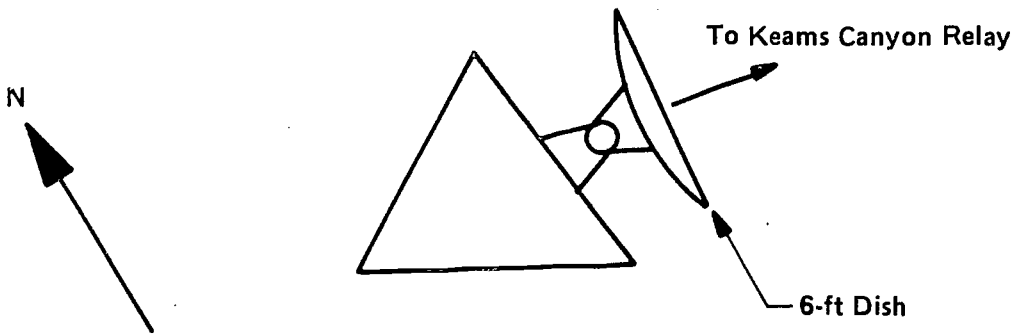
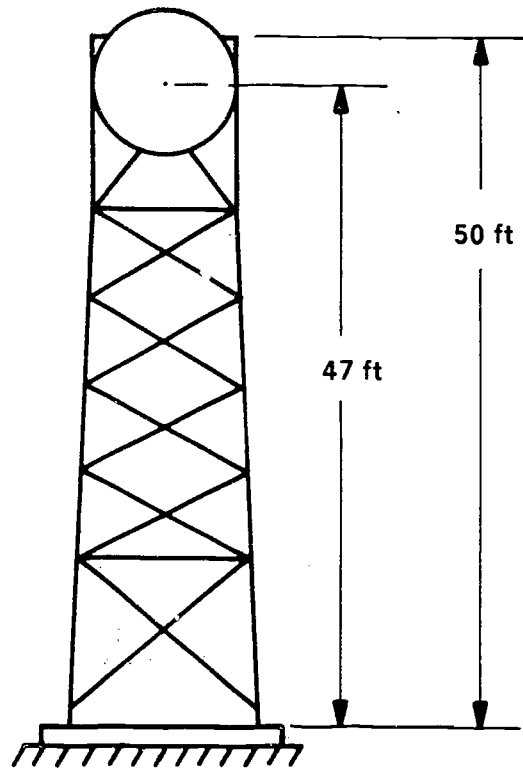

Figure D.4. New Tower and Antenna Arrangement at Second Mesa.

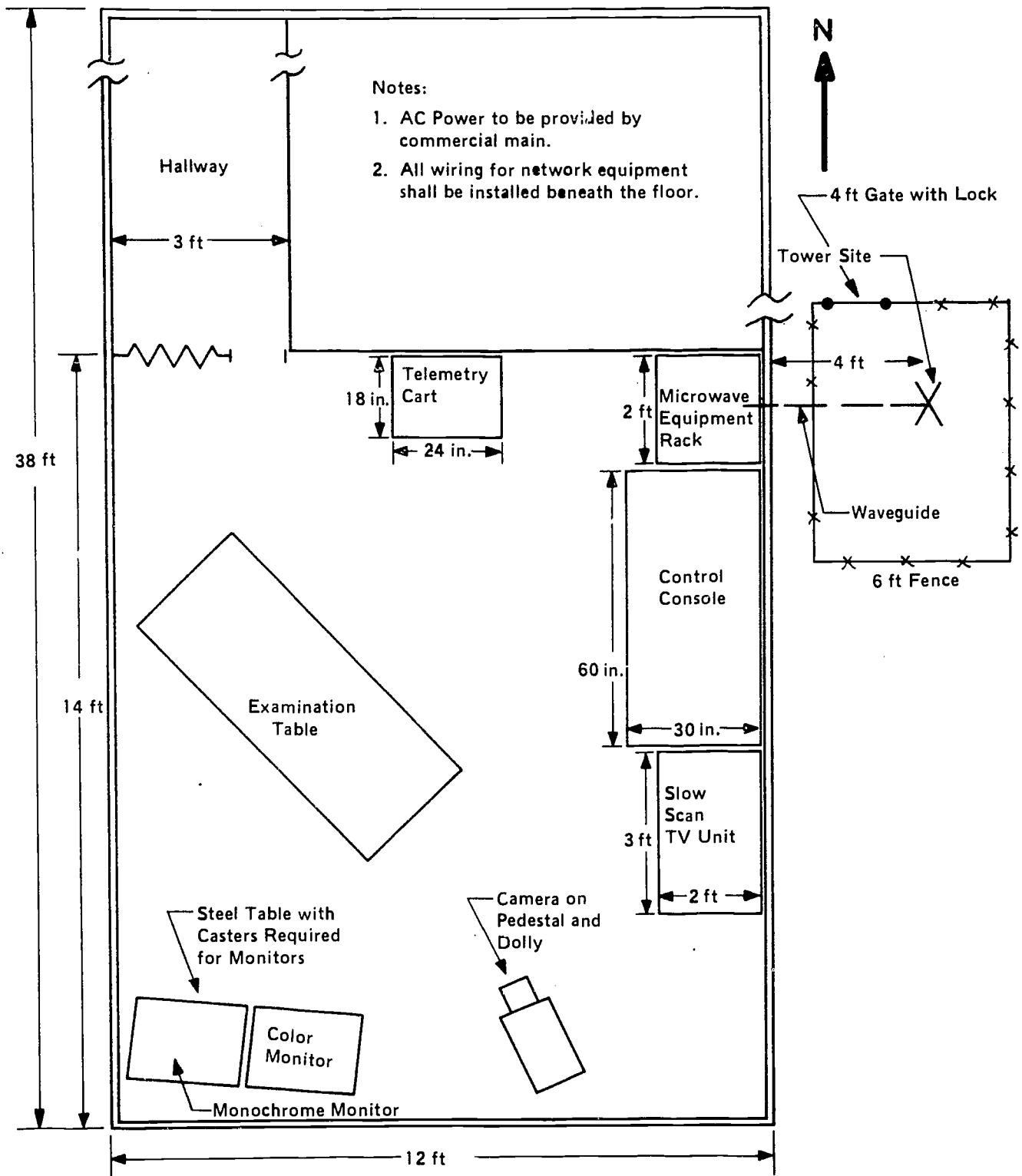

Figure D.5. Proposed Terminal Equipment Layout for New Facilities at Second Mesa Field Health Station.

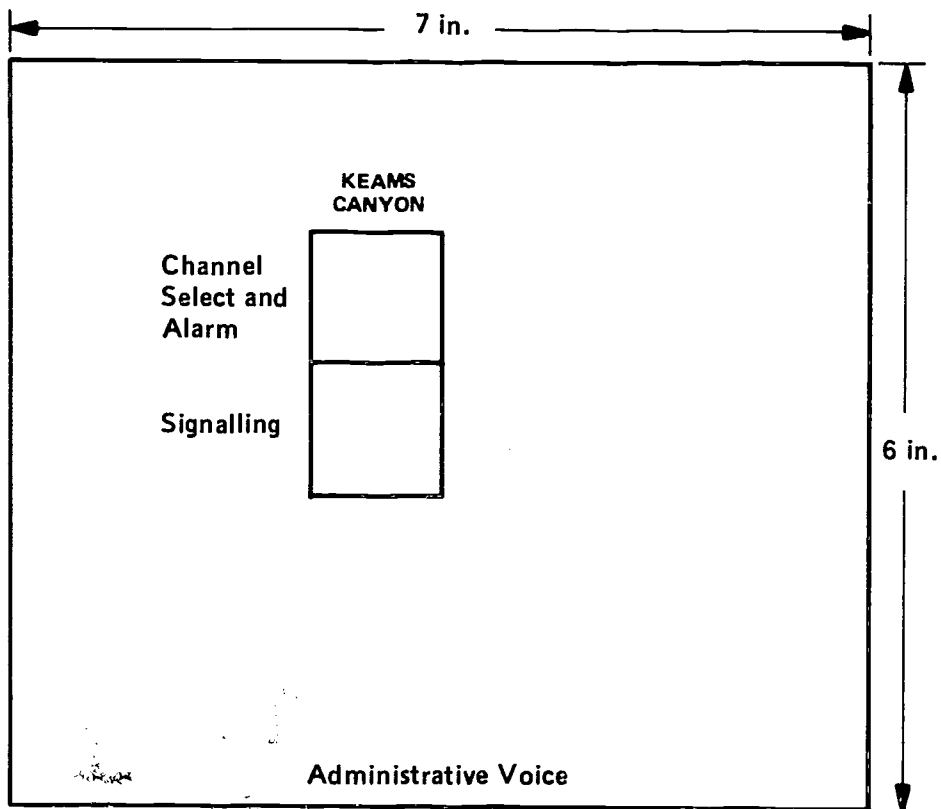

Figure D.6. AdVC Panel at Second Mesa.

Tower to be guyed in accordance with manufacturer's recommendations for specified loads.

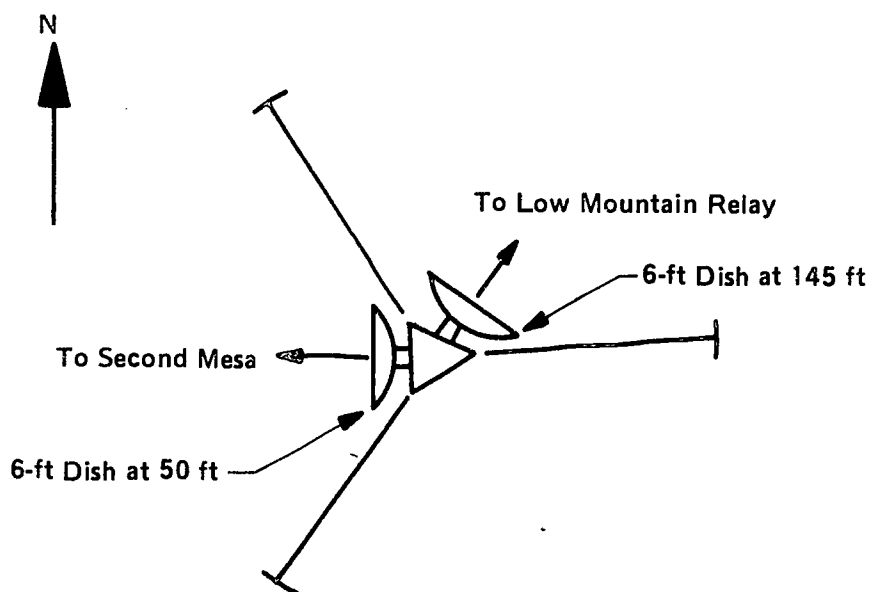
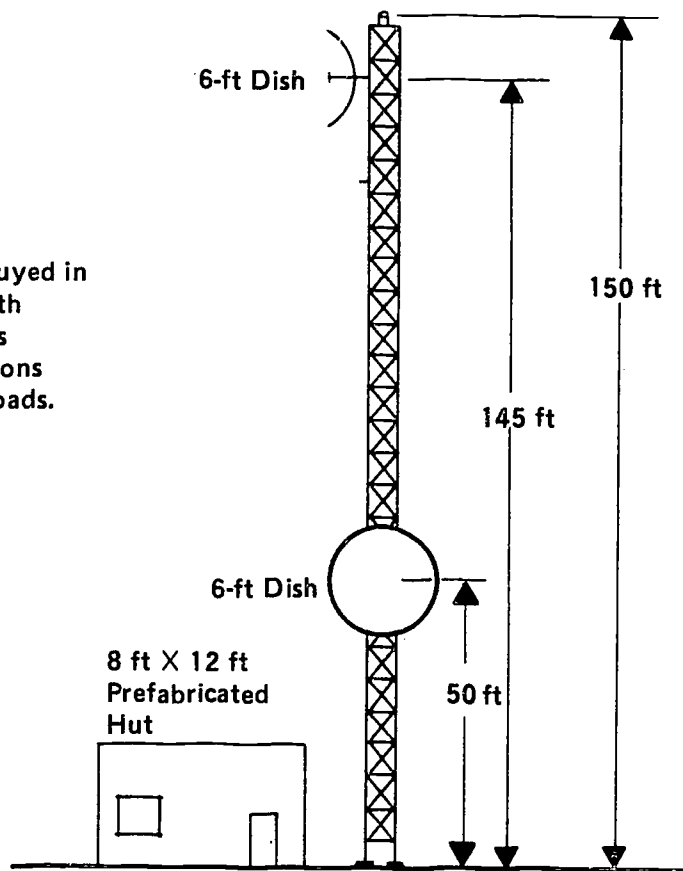

Figure D.7. New Antenna and Tower Arrangement at Keams Canyon Relay.

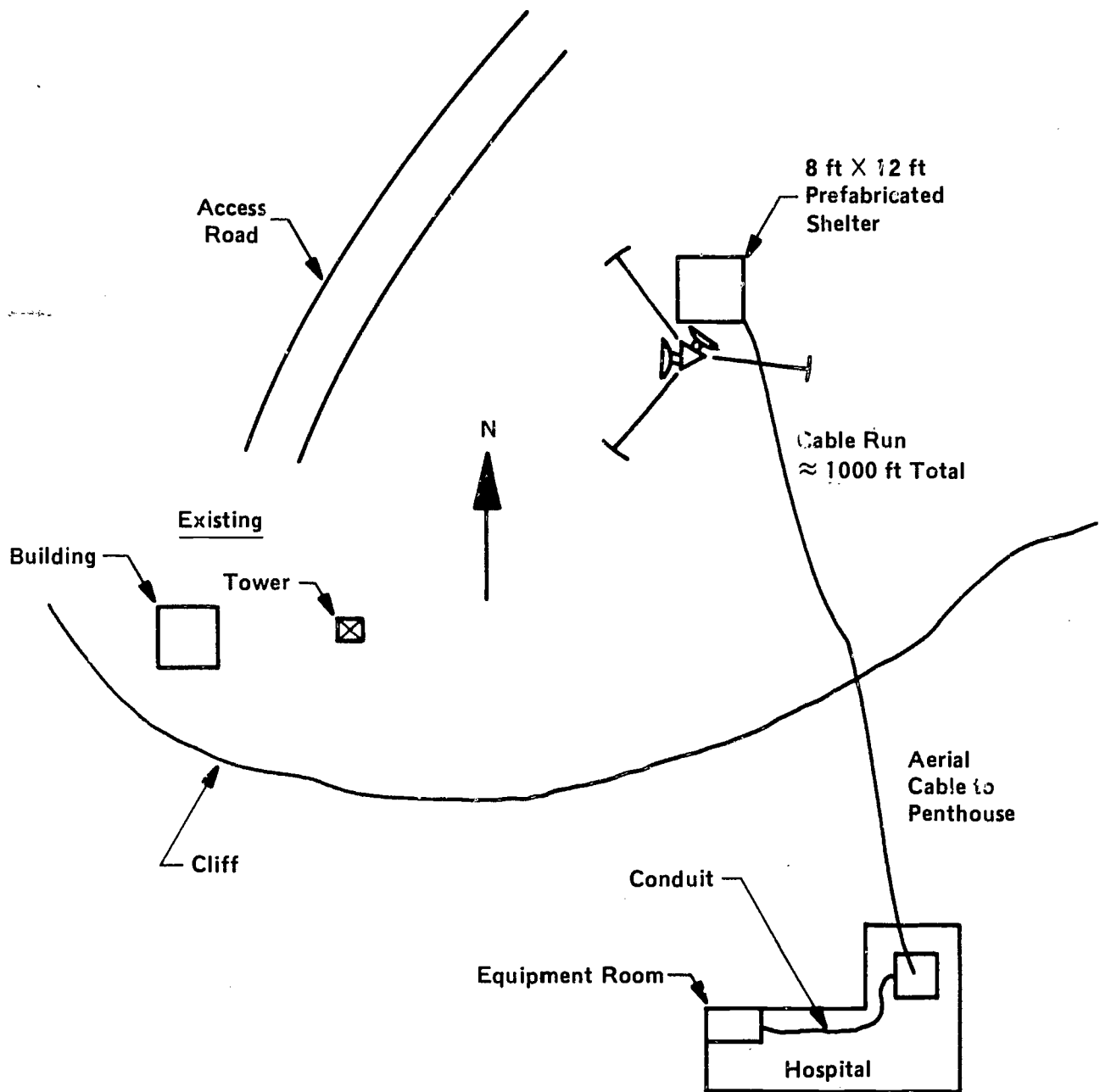

Figure D.8. Site Plan for Keams Canyon Relay and Keams Canyon Hospital.

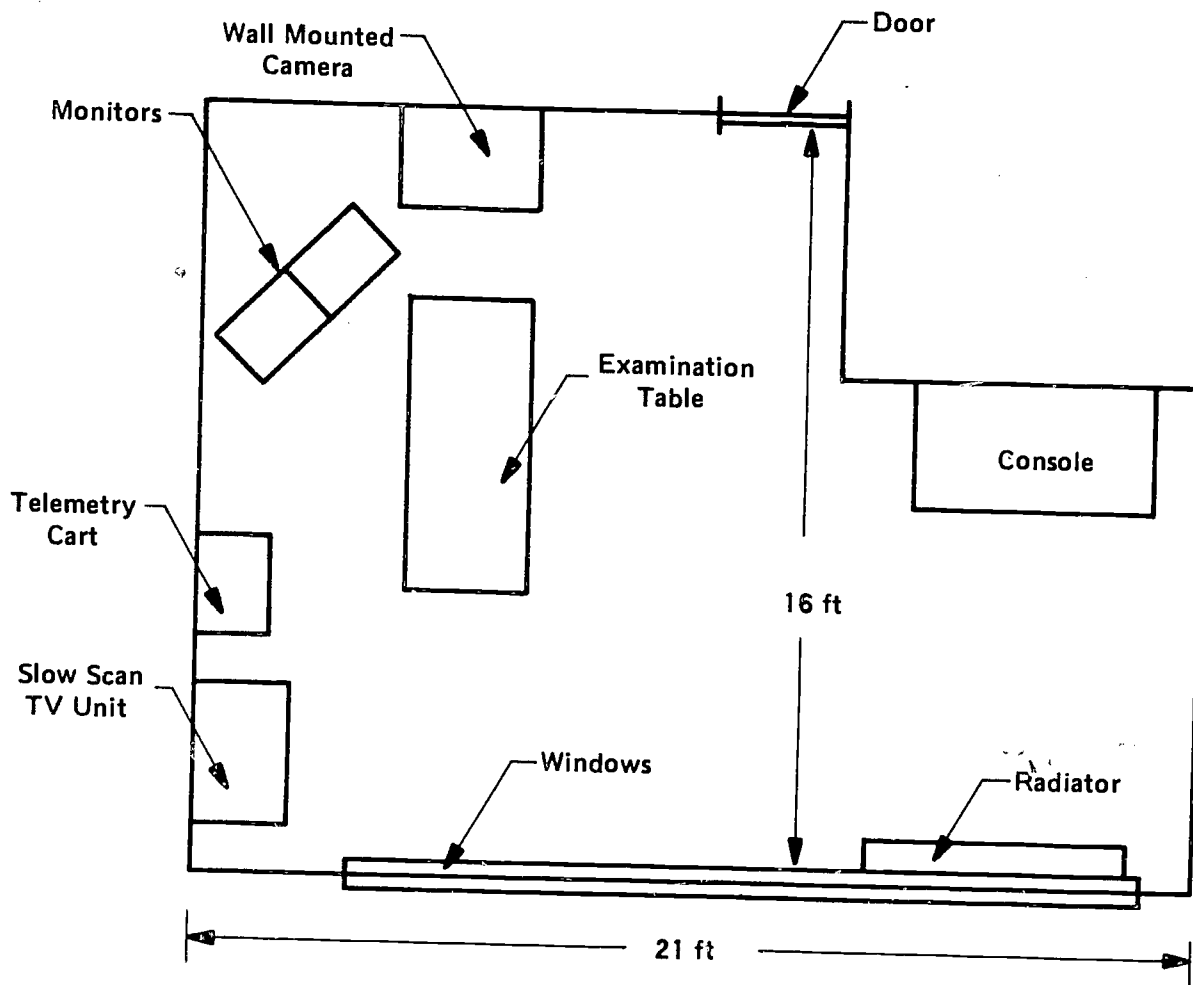
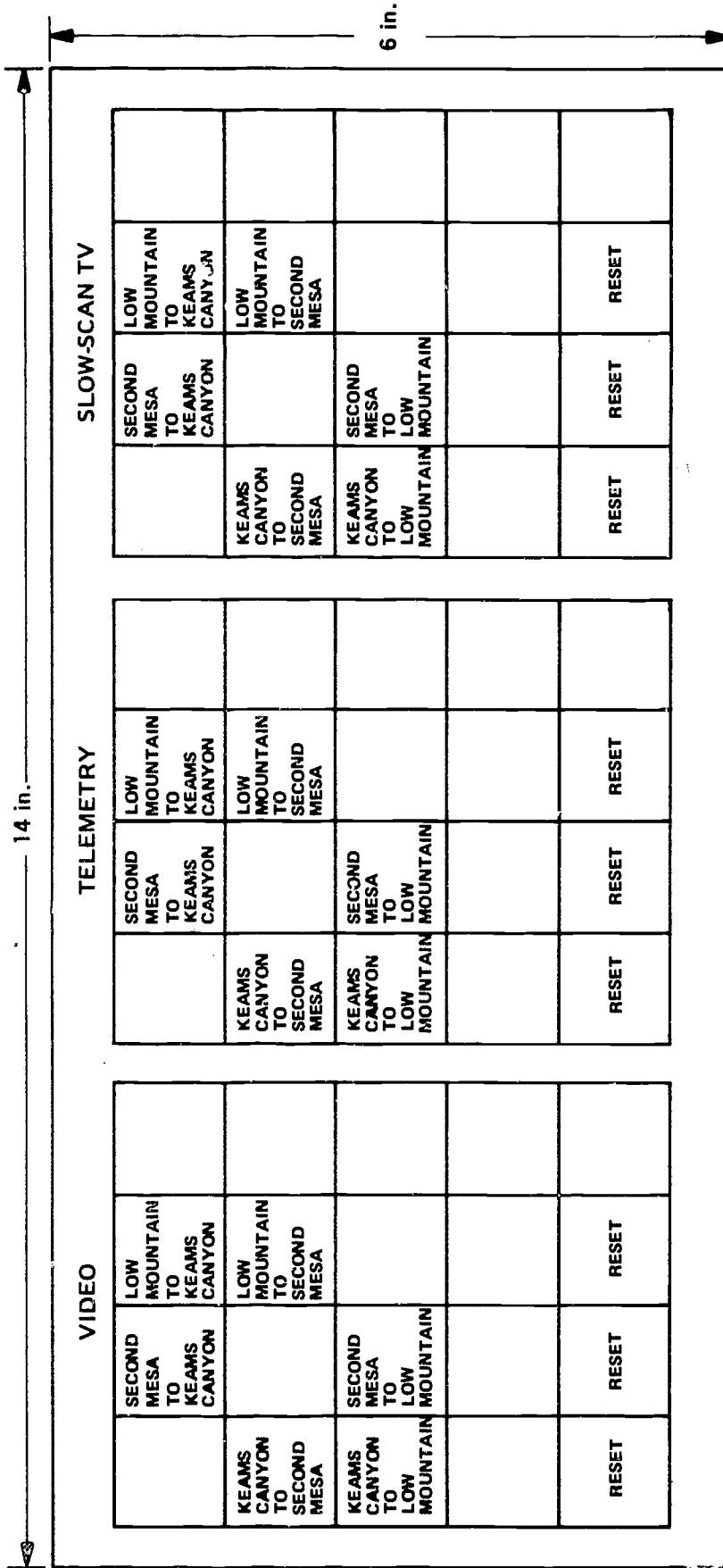

Figure D.9. Proposed Terminal Equipment Layout for Keams Canyon Hospital Conference Room.



14 in.

6 in.

SLOW-SCAN TV

TELEMETRY

VIDEO

	SECOND MESA TO KEAMS CANYON	LOW MOUNTAIN TO KEAMS CANYON	
KEAMS CANYON TO SECOND MESA		LOW MOUNTAIN TO SECOND MESA	
RESET	RESET	RESET	RESET

	SECOND MESA TO KEAMS CANYON	LOW MOUNTAIN TO KEAMS CANYON	
KEAMS CANYON TO SECOND MESA		LOW MOUNTAIN TO SECOND MESA	
RESET	RESET	RESET	RESET

	SECOND MESA TO KEAMS CANYON	LOW MOUNTAIN TO KEAMS CANYON	
KEAMS CANYON TO SECOND MESA		LOW MOUNTAIN TO SECOND MESA	
RESET	RESET	RESET	RESET

Figure D.10. Switching Control Panel Layout, Keams Canyon.

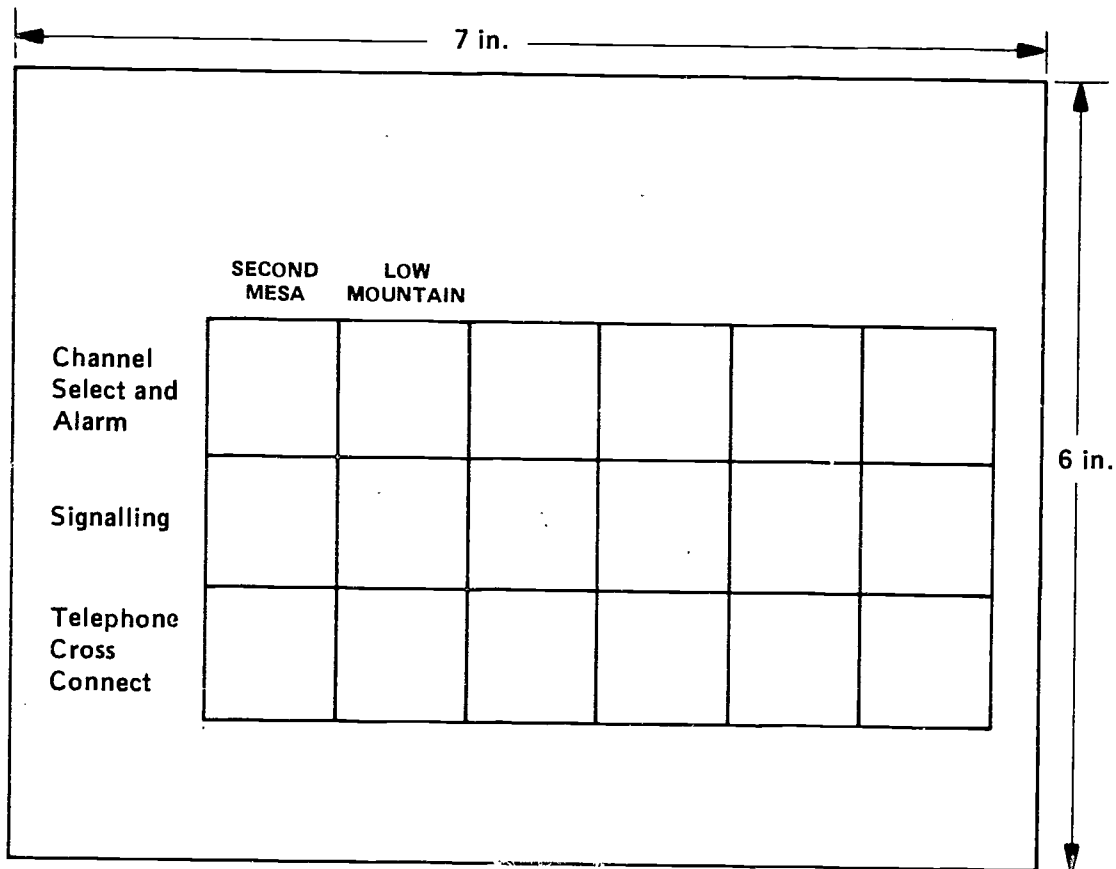

Figure D.11. AdVC Panel at Keams Canyon.

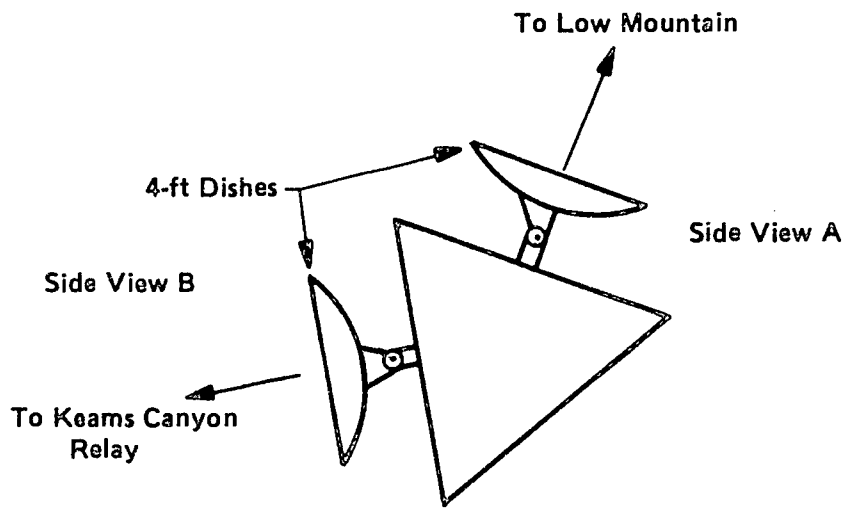
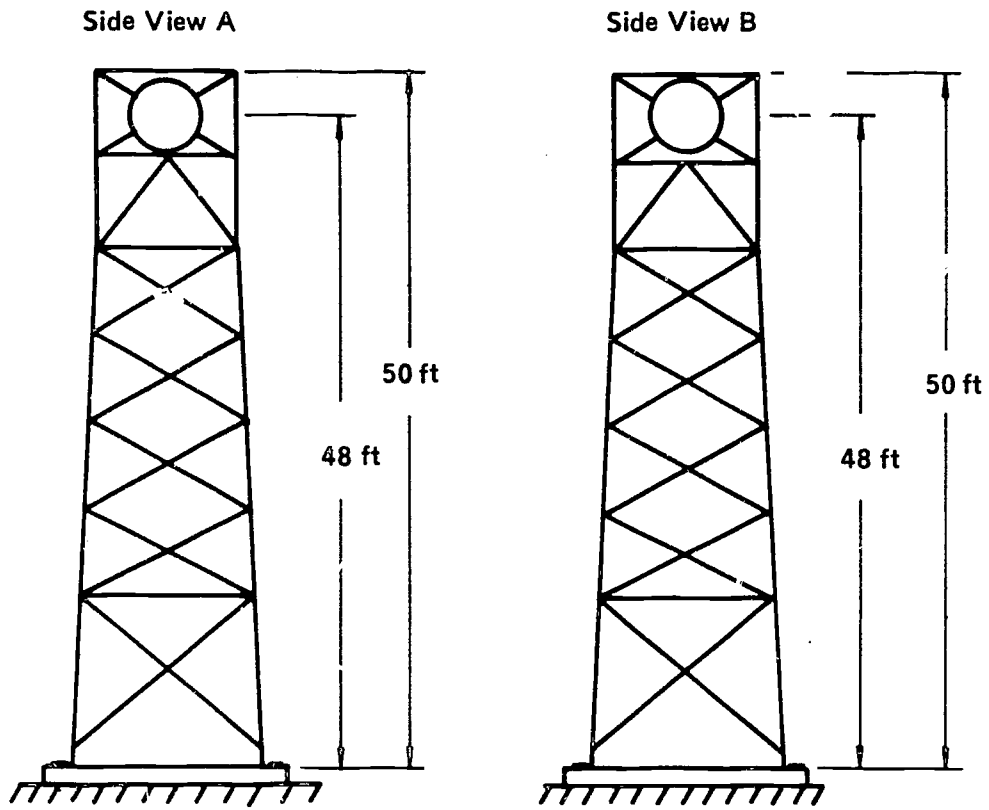

Figure D.12. New Tower and Antenna Arrangement at Low Mountain Relay.

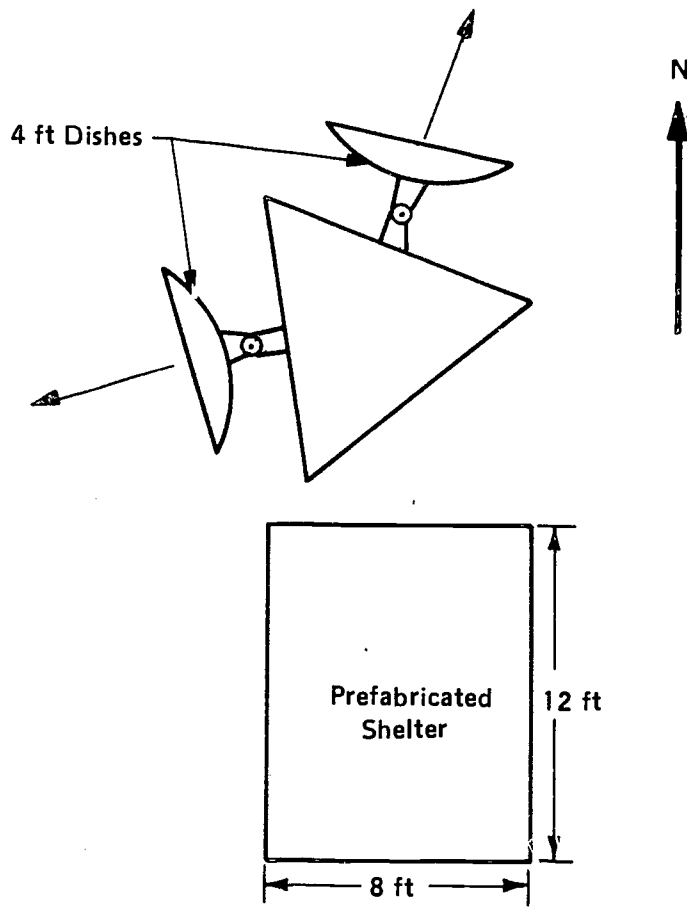
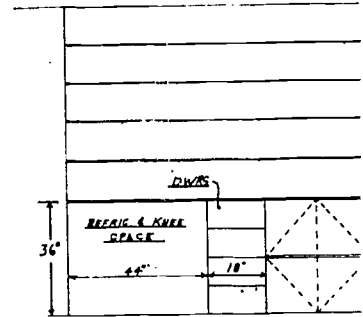
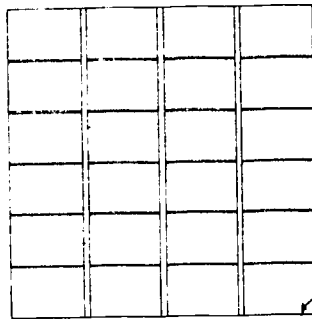
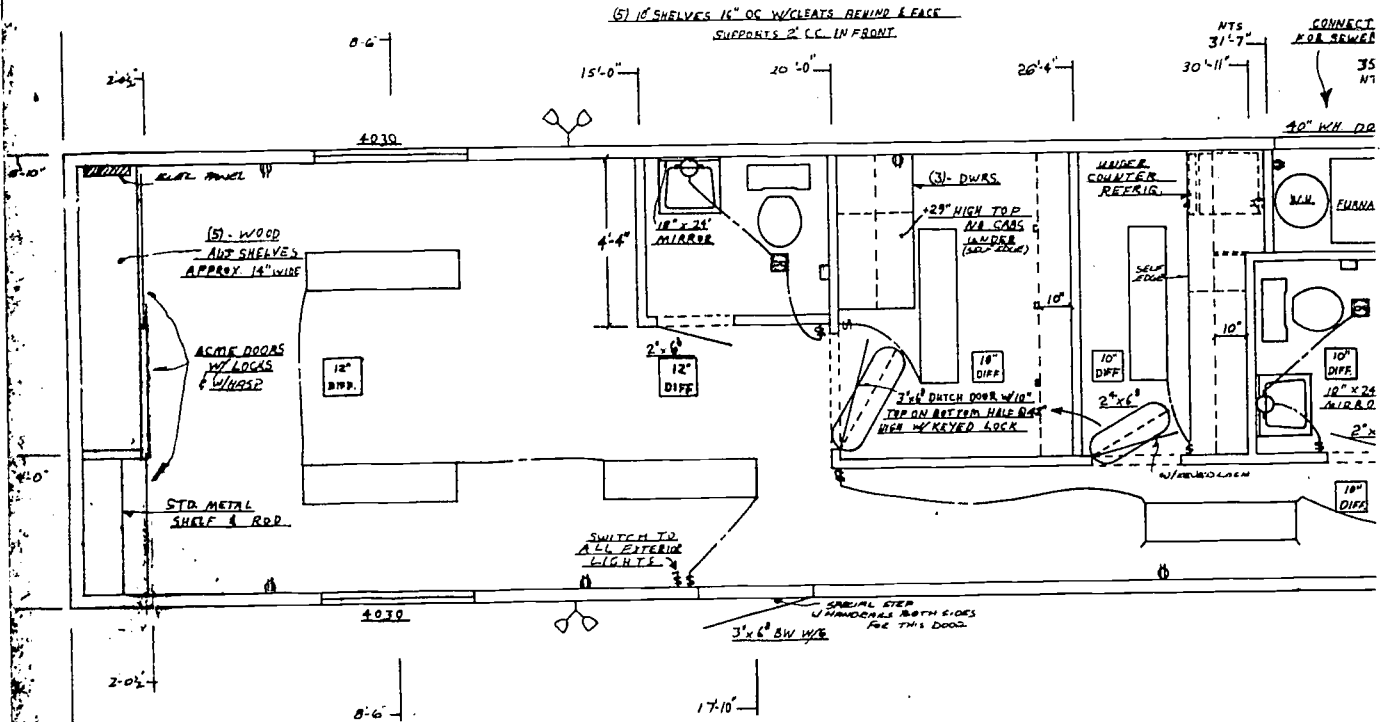

Figure D.13. Generalized Site Plan for Low Mountain Relay.



(5) 18" SHELVES 16" OC W/CLEATS BEHIND & FACE
SUPPORTS 2" C.C. IN FRONT



GENERAL EXTERIOR		INTERIOR FINISH		CABINET INFORMATION		AIR CONDITIONING	
DOOR	STD. ✓ SIZE 12' X 6'	CEILING	STD. ✓ SPECIAL	TOPS	BOULEDOUR TOP TO MATCH POWER ISL IN KITCHEN - FULL SPLAIN (8000 ELSEWHERE)	COOLING	INSTALL 5000 CFM COOLER
WINDOW	12" AXLES 2	WALLS	STD. ✓ PANELING COLOR BUTTERBUT	FACES	V7-8000	HEATING	80U -19 R&N BUTANE
SCREENS	STD. ✓ SPECIAL		SPECIAL	SIDES	V7-8000	THERMOSTATS	1- SINGLE PHASE
FLOOR	POLAR WHITE	B/R FLOOR	STD	DOORS	V7-8000	PLUMBING	
FLOOR TYPE	STD. ✓ SPECIAL	FIN. FLOOR	V.A. TILE 578 THROUGHOUT	DRAWERS		WATER LINES	COPPER ✓ COPPER C1
INSULATION	STD. ✓ SPECIAL 2\"/>						

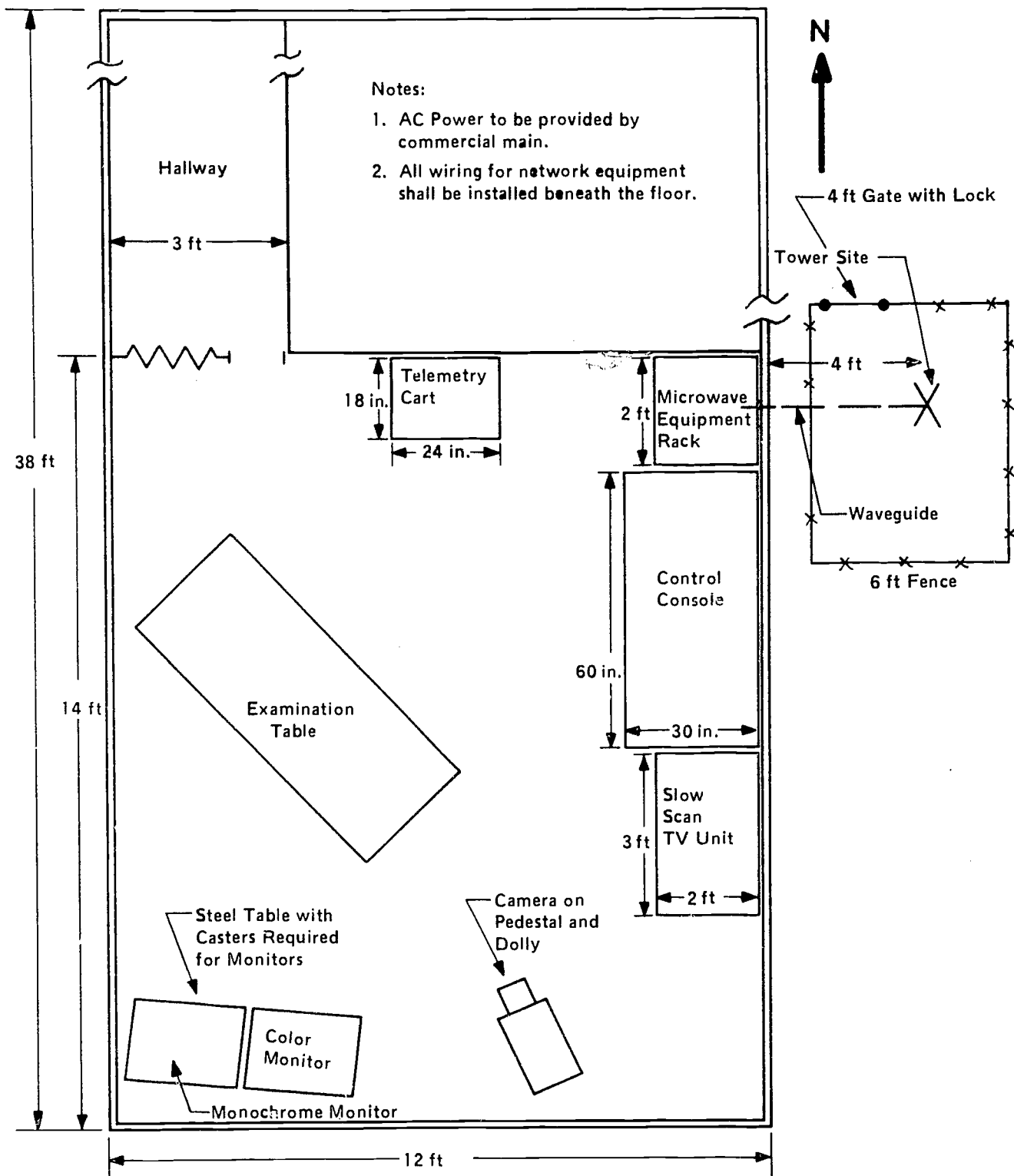

Figure D.15. Proposed Terminal Equipment Layout for New Facilities at Low Mountain.

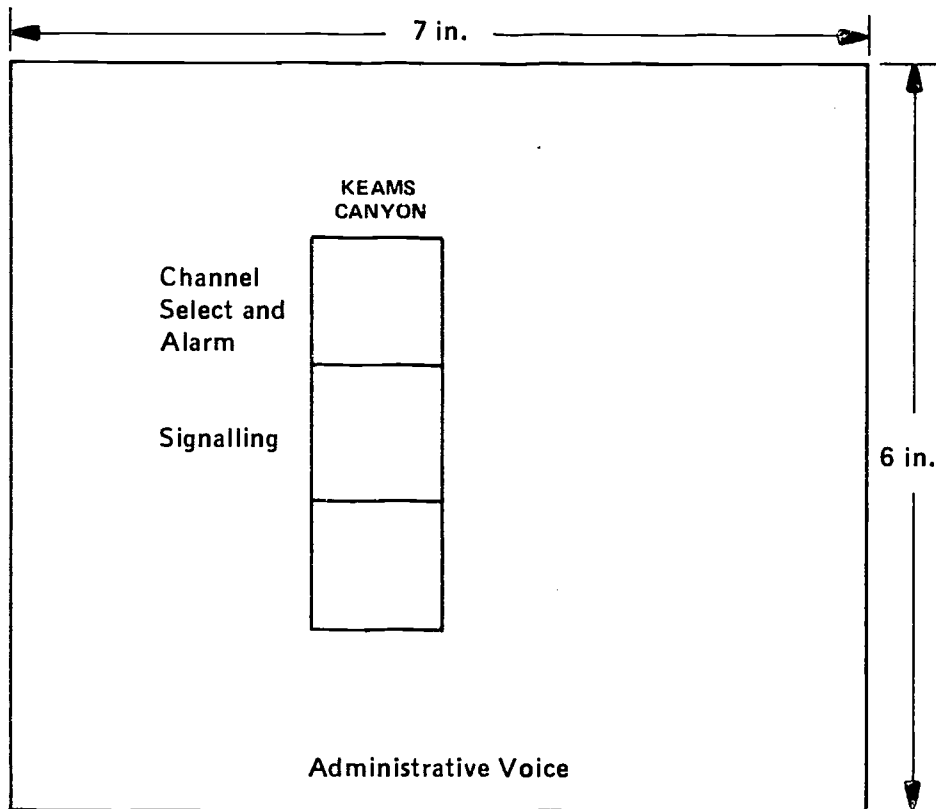

Figure D.16. AdVC Panel at Low Mountain.

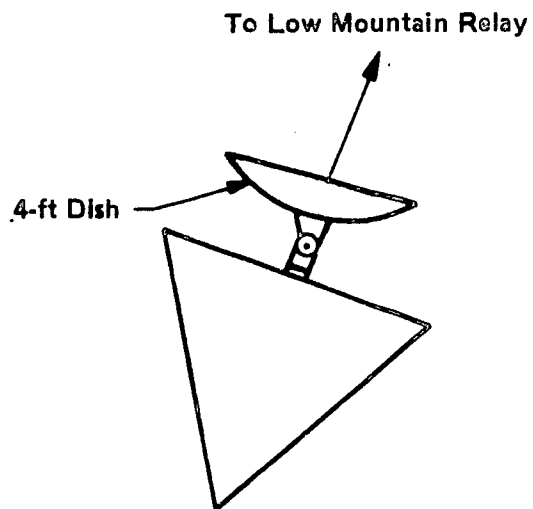
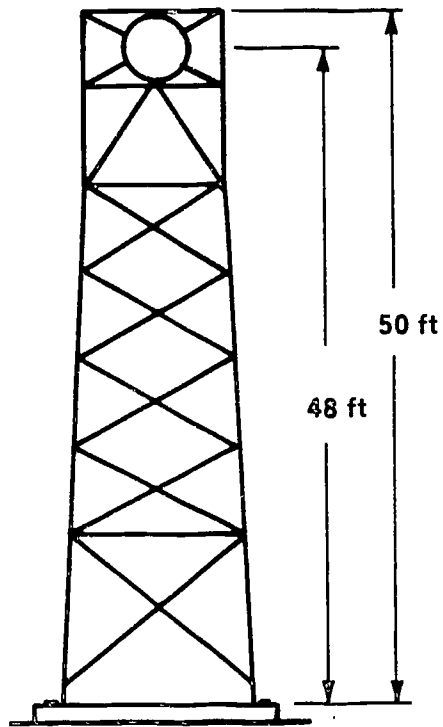
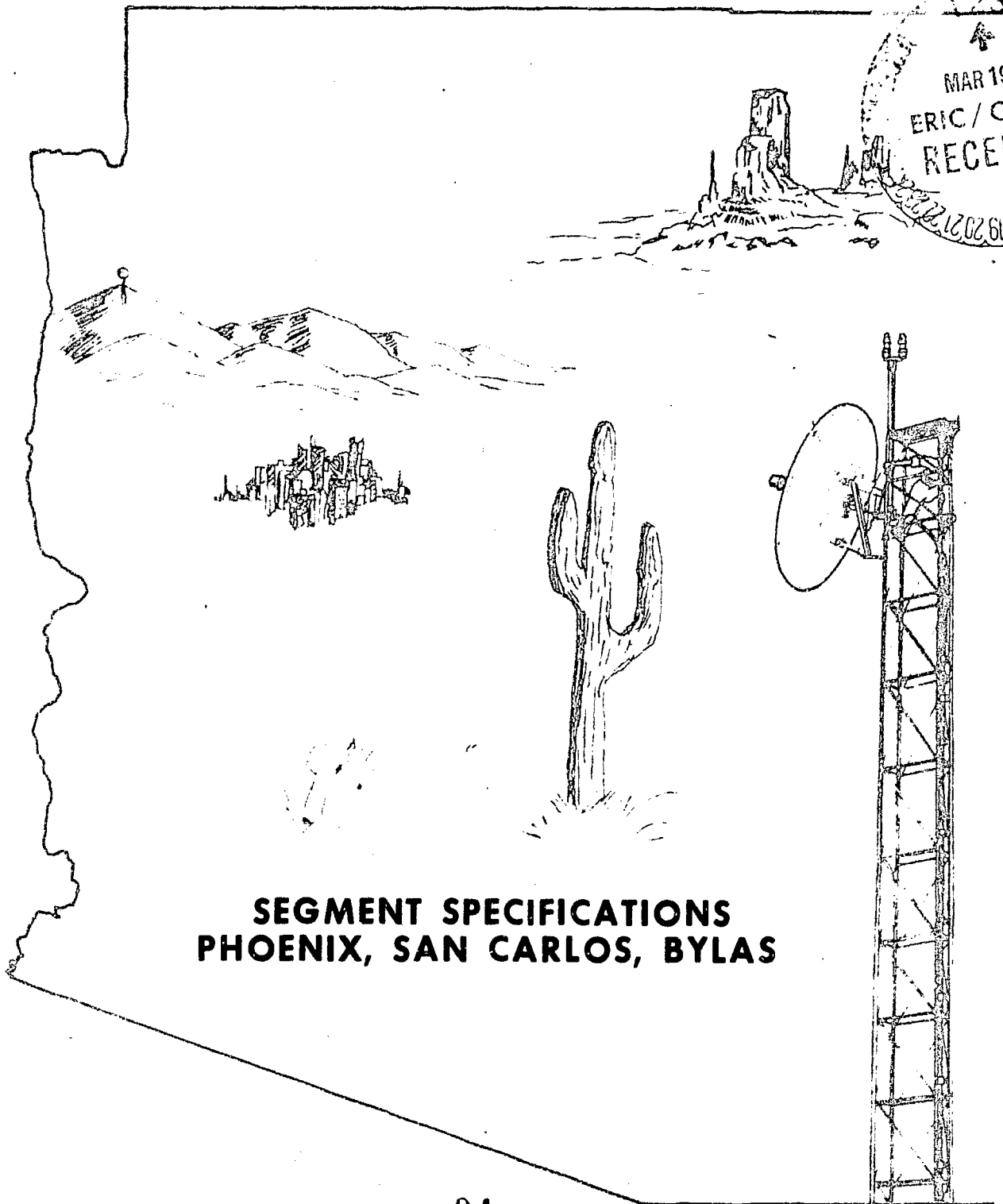

Figure D.17. New Tower and Antenna Arrangement at Low Mountain.

Arizona TeleMedicine Network



**SEGMENT SPECIFICATIONS
PHOENIX, SAN CARLOS, BYLAS**

0009027

5.00.1

THE ARIZONA TELEMEDICINE NETWORK

SEGMENT SPECIFICATIONS

Phoenix Indian Medical Center

San Carlos

Bylas

Prepared for:

**The University of Arizona College of Medicine
Department of Family and Community Medicine
Tucson, Arizona 85724**

Prepared by:

**The Biomedical and Special Systems Group
Telecommunications Activity
Atlantic Research Corporation
Alexandria, Virginia 22314**

May 30, 1973

TABLE OF CONTENTS

	Page
1.0 SCOPE	1-1
2.0 SYSTEM DESIGN	2-1
2.1 Communications Channels	2-1
2.2 Selection of Microwave Routes	2-2
2.3 Control of Signal Switching	2-5
2.3.1 Pinal Peak Switch Point (Class "R1" Station)	2-5
2.3.2 Phoenix Switch Point (Class "c" Station)	2-6
2.3.3 Control Panel Associated with Phoenix	2-7
2.3.4 Control Panel Associated with San Carlos	2-7
3.0 APPLICABLE DOCUMENTS	3-1
4.0 SPARE EQUIPMENT AND MATERIALS REQUIREMENT	4-1
APPENDIX A – Path Profile	
APPENDIX B – Site Maps	
APPENDIX C – Site Photographs	
APPENDIX D – Drawings	

page ii is blank

1.0 SCOPE

This document defines one segment of the Arizona TeleMedicine Network as referred to in the System Procurement Specifications. The basic requirements shall be as given by the general document as amended by unique requirements for this segment given herein.

The segment defined here is a communication link between the Phoenix Indian Medical Center, a peripheral hospital at San Carlos and the field health station at Bylas, via a switching relay at Pinal Peak. Figure 1.1 illustrates this segment.

This document describes all equipment required to implement the segment and details all allowances to be made to facilitate anticipated expansions to the network.

- Field Health Stations
- ⊕ First Level Referral Center
- ◐ Second Level Referral Center
- Switching Relay
- Microwave Path Required this Segment
- - - - Proposed or Existing Microwave Paths (not part of this segment)

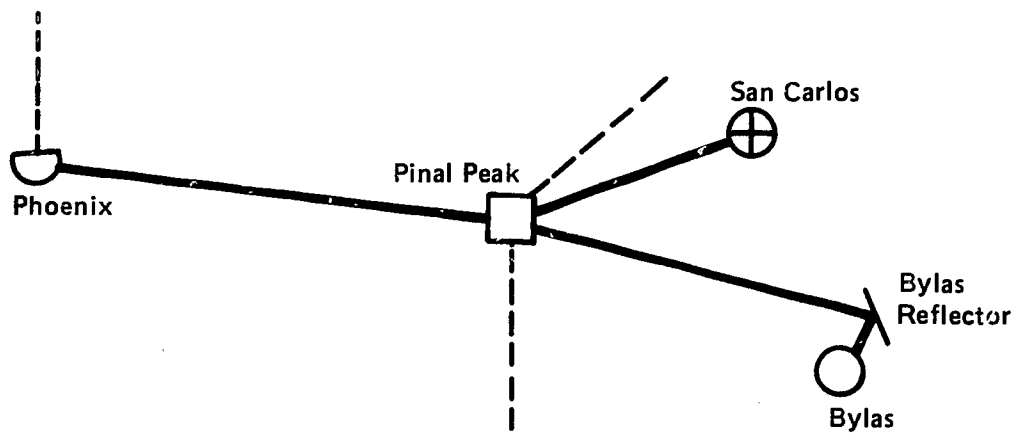

Figure 1.1. Phoenix Indian Medical Center, San Carlos, Bylas — Segment.

2.0 SYSTEM DESIGN

2.1 Communications Channels

The full duplex microwave segment shall be channelized to carry the following services.

- Full color television (525 line/30 frame with 5.5 MHz bandpass) – one channel
- Program audio (15 kHz bandpass) – one channel
- Order wire (with selective signaling) – one channel
- “Voice” slots (FDM, 4 kHz spacing) – up to 12 channels
- Alarm circuits – see channelization plan.

A further breakdown of the use of the “voice” slots is included in the suggested spectrum utilization plans for each link within the segment (see Appendix D, 1-4).

The designated voice slots shown are to be used for the following services:

- Camera positioning control (tilt, pan, focus, zoom, iris, mono/color) – six channels (dc control) per voice slot
- Teleprinter/keyboard (300 baud) – six channels per voice slot, one channel per site
- Telemetry (IRIG Standard) dc to 500 Hz – one channel, single voice slot per site
- Slow-scan television (approximately one frame per two-minute interval) – one channel, single voice slot

- Switching control relay sites, remote – touch tones, share administrative voice slot
- Administrative Voice Channel(s) – see channelization plan.

Locations in the network shall be provided with modems, FSK transmitter/receivers, FM telemetry devices and such required interface equipment so as to facilitate these services at each terminal site.

2.2 Selection of Microwave Routes

The suggested sites for this segment are described as follows. Path profiles, site maps, photographs and drawings are provided in Appendices A, B, C and D, respectively.

Pinal Peak

This site is already heavily used as a radio relay by many different users. The Arizona TeleMedicine Network will share the existing building owned by the Bureau of Indian Affairs. Hard surface roadway and commercial power are available.

A 10- by 10-foot block building owned by the Bureau of Indian Affairs (BIA) is to be made available for joint use by the Arizona TeleMedicine Project. To provide additional space within the building, an existing propane gas standby power system is to be removed by the Contractor. This unit is to be disposed of according to instructions to be provided by the BIA. A new generator, with an appropriate weather housing, shall be installed by the Contractor at some point near the existing building. This unit shall have sufficient power producing capability to drive both the existing BIA radio equipment and the proposed Arizona TeleMedicine Network equipment. Gas storage capacity shall be provided by the Contractor such that all equipment can be supplied with standby power for at least 72 hours.

The existing BIA tower is to be removed by the Contractor and disposed of in accordance with instructions to be provided by the BIA. The Contractor shall relocate the existing VHF antennas to the top of the new tower.

A new tower as per D.17 is to be provided by the Contractor. The Tower shall be capable of supporting the three specified parabolic antennas. Allowance, including wind and ice loads, is to be made for the addition of four 8-foot parabolic antennas near the top of the tower. "

The Contractor shall have the responsibility of assuring minimal interruption of the existing radio service and restoration of this service upon completion of installation. The Contractor shall render assistance as requested by the BIA in this installation. This task shall include installing and fastening the RF transmission lines associated with the mobile radio antennas. The Contractor shall supply new materials, such as antenna mounting hardware, RF transmission lines and hangers. Contractor shall provide an appropriate ice shield to protect the BIA building from falling ice.

It is recognized that the space at this site is severely limited. Nevertheless, the Contractor shall arrange all new and existing equipment within the building such that maintenance can be effected without the need to disconnect waveguide or to move equipment racks. Wall-mounted equipment shall be permitted so long as swingout or rollout shelves are used.

Grounding requirements are to be in accordance with recognized industry practice. A specific requirement is to drive one 3/4-inch by 10-foot copper clad grounding rod at the base of each tower leg and bond the tower base, ground rods and equipment racks together using 2-0 stranded copper.

Bylas

Bylas field health station is to be supplied with a mobile home type trailer as an annex to the existing building. This addition to the field health station to accommodate the TeleMedicine facilities is to be provided by others and is not a cost item for consideration by the Contractor. All modifications to this unit associated with the Arizona TeleMedicine project are the Contractor's responsibility. The Contractor is to provide all office furniture, examination table, and miscellaneous medical items as well as all components directly associated with the terminal site installation. Medical equipment is listed in Appendix D.20. A tower is required at this site D.19. The tower shall be capable of supporting the specified parabolic antennas and allowance, including wind and ice load, is to be made for the addition of up to at least one 8-foot parabolic antenna installed near the top of the tower. This site is supplied by commercial power and shall be equipped with a standby generator as per the System Procurement Document.

Bylas Reflector Site

This site is located about 1-1/2 miles northeast of Bylas. A minimum size reflector of 20 by 32 feet is to be installed. Installation shall be in accordance with EIA specified in RS-195A, "Electrical and Mechanical Characteristics for Microwave Relay Antennas and Passive Reflectors."

San Carlos

Equipment space and suitable power are available at this hospital. Minor electrical wiring modifications are required. A tower is required as per D.18. The tower shall be capable of supporting the specified antenna and an allowance, including wind and ice load, is to be made for the addition of at least one 8-foot parabolic antenna installed near the top of the tower.

Phoenix Indian Medical Center

Equipment space is not available in the penthouse at the Phoenix Indian Medical Center. Contractor shall provide a prefabricated equipment shelter on the roof immediately adjacent to the penthouse and inside the decorative screen. Standby power and room temperature air is available at this level on the building.

The exhaust air (second and third floor room air exhaust) from the hospital shall be appropriately filtered and utilized for circulation through the shelter in lieu of the self-contained heating and/or cooling devices at most other sites.

The Contractor's responsibility shall include the sheet metal work involved in channeling the exhaust air from the nearby vent through the equipment shelter. The conduit and power wiring from within the penthouse to the equipment shelter is also the responsibility of the Contractor.

A 10-foot stub tower, as per D.16. is required on the penthouse roof. The tower shall be capable of supporting the specified antennas and an allowance, including wind and ice load, made for the addition of at least one 8-foot parabolic antenna installed near the top of the tower. Any necessary relocation of the existing television and VHF radio antennas or their support structures shall be the Contractor's responsibility. Restoration of any interruption in these services as may be caused by the Contractor in the course of his work shall be prompt. Also a foundation is not called for; instead steel skids will bear the load.

In addition to general grounding requirements, a specific requirement is to bond the stub tower base and equipment main frames to the lightning rod ground system using 2-0 stranded copper.

2.3 Control of Signal Switching

In this segment of the Arizona TeleMedicine Network, the following control and switching relationships shall prevail:

<u>Switching Relay</u>	<u>Control Station</u>
Pinal Peak	Phoenix/San Carlos
Phoenix	Phoenix

Refer to System Procurement Specifications document for general discussion of switching concepts.

The various switch configuration for each switch point are described in the following paragraphs. Note that blank panels are to be provided for switching functions which will be added as the network expands. However, if a portion of a switch matrix is to be used in this segment, the entire matrix shall be installed. Only the switch positions specifically called for in this segment are to be wired.

Each Class "b" or Class "c" station will have installed, when applicable, as an integral part of its control panel, a group of illuminated push buttons which control the origin of the station's switching control tones. These tones will be generated by oscillator modules that produce the dual frequency notes commonly called "touch tones." Depending on which set of tones is generated over which Administrative Voice Channel, a particular cross point on a matrix located at a remote switching relay station will be energized. In the arrangement associated with Phoenix, the switching takes place locally and does not involve tone control. The push buttons in this case shall control the matrix switch points through a direct connection. The administrative voice channel control panel is installed in the console.

2.3.1 Pinal Peak Switch Point (Class "R1" Station)

General

At this site three transmitter/receiver (T/R) pairs¹ are brought together for switching. They are listed below:

¹Up to two transmitter/receiver pairs will be added as the network expands. Make allowance for rack space and power requirements.

Phoenix: This T/R pair links the Phoenix Indian Medical Center with the Pinal Peak switching center.

San Carlos: This T/R pair links the San Carlos Indian Health Service Hospital with the Pinal Peak switching center.

Bylas: This T/R pair links the Bylas Clinic to the Pinal Peak switching center.

In remote command of the various switch configurations at Pinal Peak is Phoenix, a Class "c" station and San Carlos, a Class "b" station.

The control tones, originated by Phoenix used to actuate the Pinal Peak switching equipment are carried via the Phoenix to San Carlos administrative voice channel. The control tones originated by San Carlos used to actuate the Pinal Peak switching equipment are carried via the San Carlos to Bylas administrative voice channel. In general, each transmit and receive circuit of the duplex link is switched separately.

2.3.2 Phoenix Switch Point (Class "c" Station)

General

In this segment one transmit/receiver (T/R) microwave pair¹ comes together at the Phoenix Indian Medical Center terminal site. In addition to this remote link, one must consider the signals generated and received by Phoenix itself as another T/R pair. Furthermore, it can be projected that expansions both within and outside of the Phoenix Indian Medical Center will create additional inputs that should be considered at this time in setting requirements.

The initial T/R pairs may be identified as described on the list below :

Pinal : This T/R pair serves as the link to the Pinal Peak switching relay.

Phoenix : The Phoenix designation for this pair signified the link to the first of what may grow to a large number of specialists telediagnosis rooms located throughout the hospital, or, at least, on its grounds. In command of the various switch configurations at Phoenix is the control panel at Phoenix. These control signals shall be carried via hard wire from the remote terminal site to the switch matrix. In general each transmit and receive circuit of the duplex link is switched separately.

¹Up to two transmitter/receiver pairs will be added as the network is expanded. Make allowance for rack space and power requirements.

2.3.3 Control Panel Associated with Phoenix

A drawing of the switching control panel at Phoenix is shown as Figure D.10. The drawing shows the switching requirement for the video, slow-scan TV and telemetry functions for control of the Pinal Peak. Other switching functions will be added as the network expands.

2.3.4 Control Panel Associated with San Carlos

A drawing of the switching control panel at San Carlos is shown in Figure D.11. The drawing shows the switching requirement for video, slow-scan TV and telemetry functions. This panel is mounted within the control console as shown in Figure D.15. The administrative voice channel control panel is installed in the console.

3.0

APPLICABLE DOCUMENTS

The Arizona TeleMedicine Network,
System Procurement Specifications, May 1973

3-1

106

page 2-8 is blank

4.0 SPARE EQUIPMENT AND MATERIALS REQUIREMENT

The Contractor shall, as part of his construction contract, supply the following list of spare parts, components, panels, equipment and material. Delivery shall be to the site as stipulated by the Project Director. Delivery shall be effected prior to final acceptance.

2 sets	Matched 1-inch camera tube replacements
1 each	Color monitor (type as supplied at each site)
1 each	Monochrome monitor, large (type as supplied at each site)
1 each	Twin small monochrome monitors (type as supplied in each console)
1 each	Audio logging recorder (type as supplied in each console)
1 each	Video logging recorder (type as supplied in each console)
2 each	Video DA modules (type as supplied in each console)
2 each	Video DA power supply (type as supplied in each console)
1 each	Audio mixer and limiter (type as supplied in each console)
1 set	Modules for multiplex equipment (12 channels)
1 set	Common equipment modules, panels and circuit boards (not channel dependent) for microwave radio equipment for both 6 GHz and 12 GHz units
4 each	Video switcher modules
4 each	Audio frequency switcher modules
1 set	Telemetry equipment modules
4 boxes	Fuses of all types

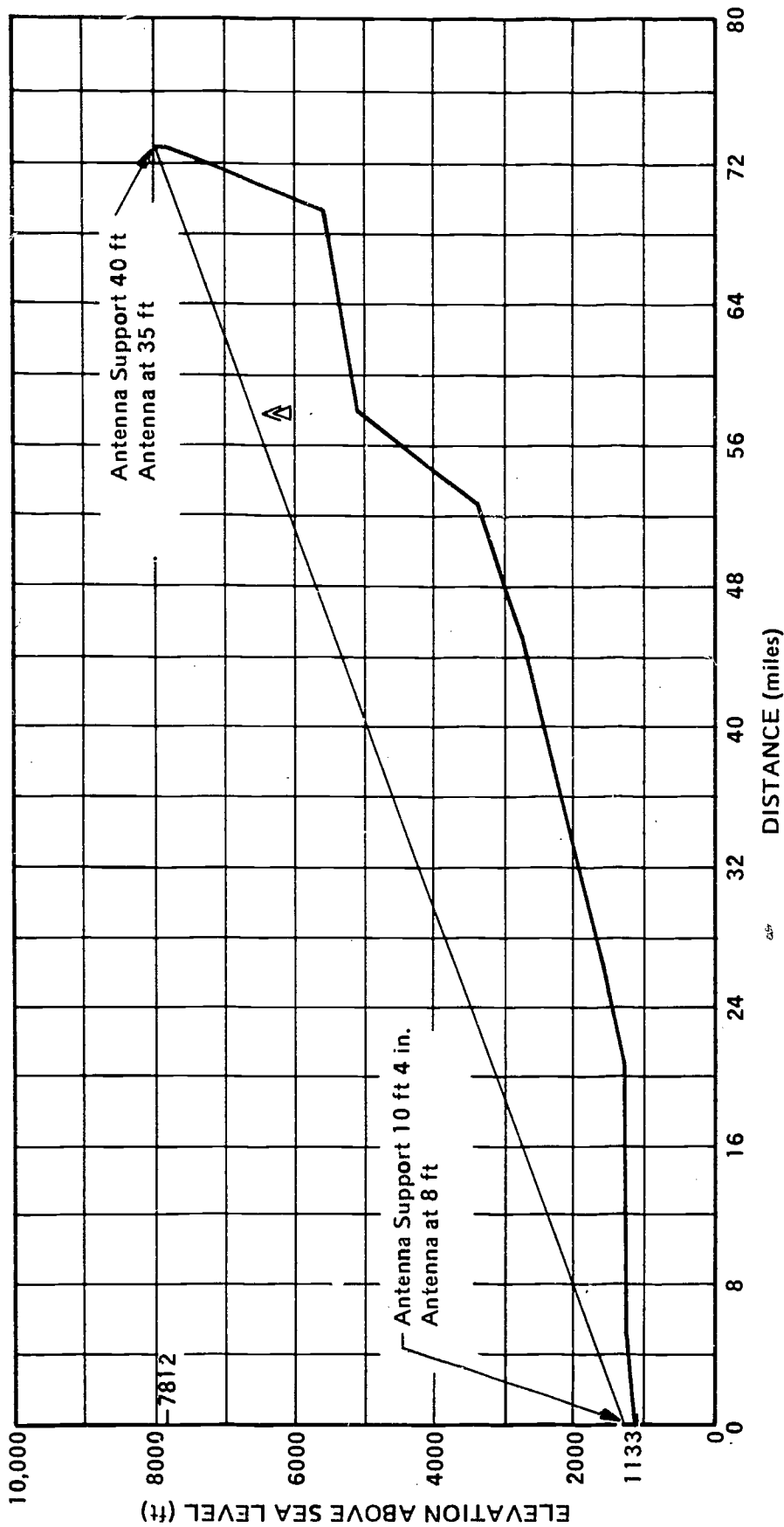

Figure A.1. Microwave Path Profile, Phoenix to Pinal Peak.

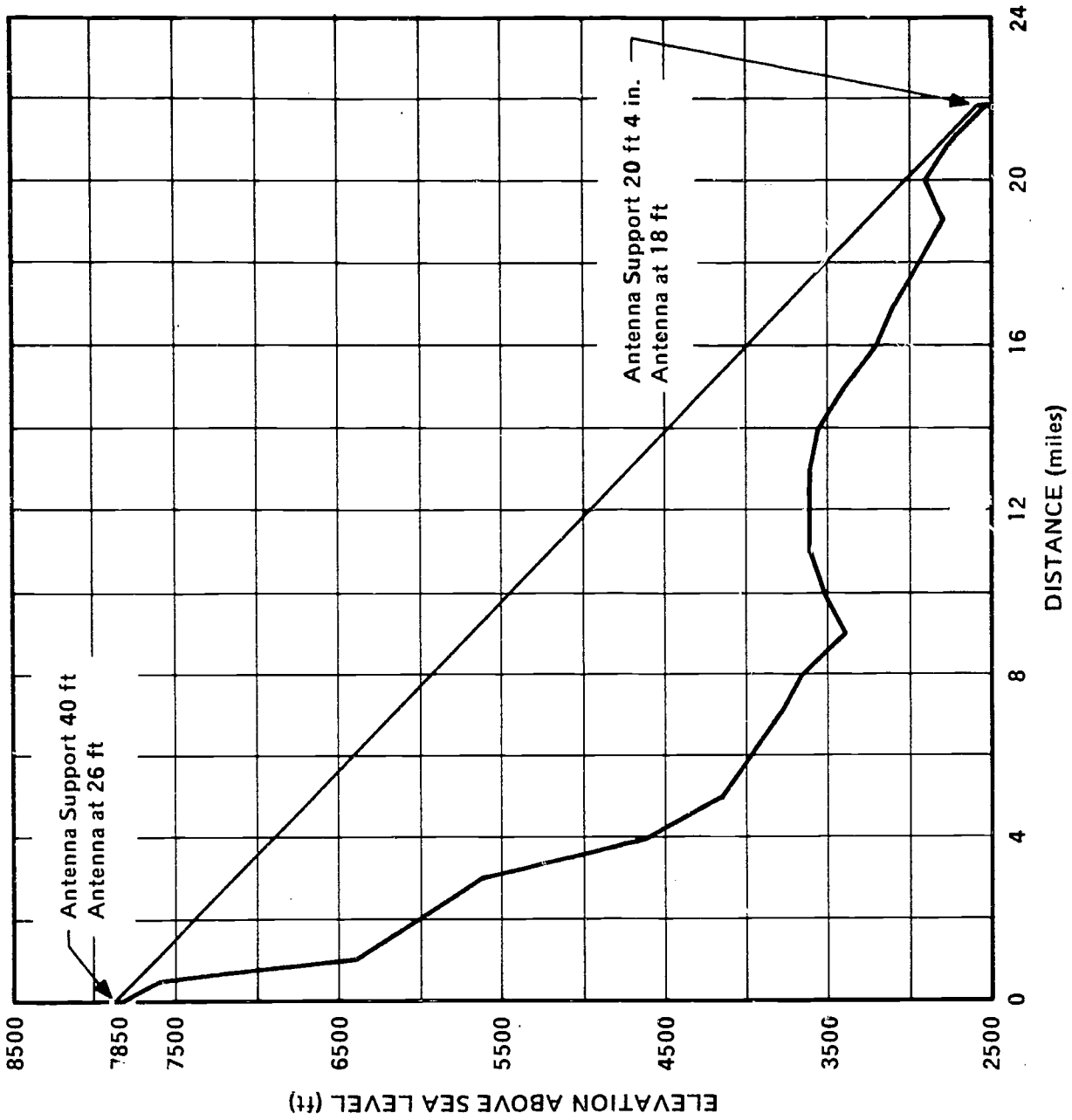

Figure A.2. Microwave Path Profile, Pinal Peak to San Carlos.

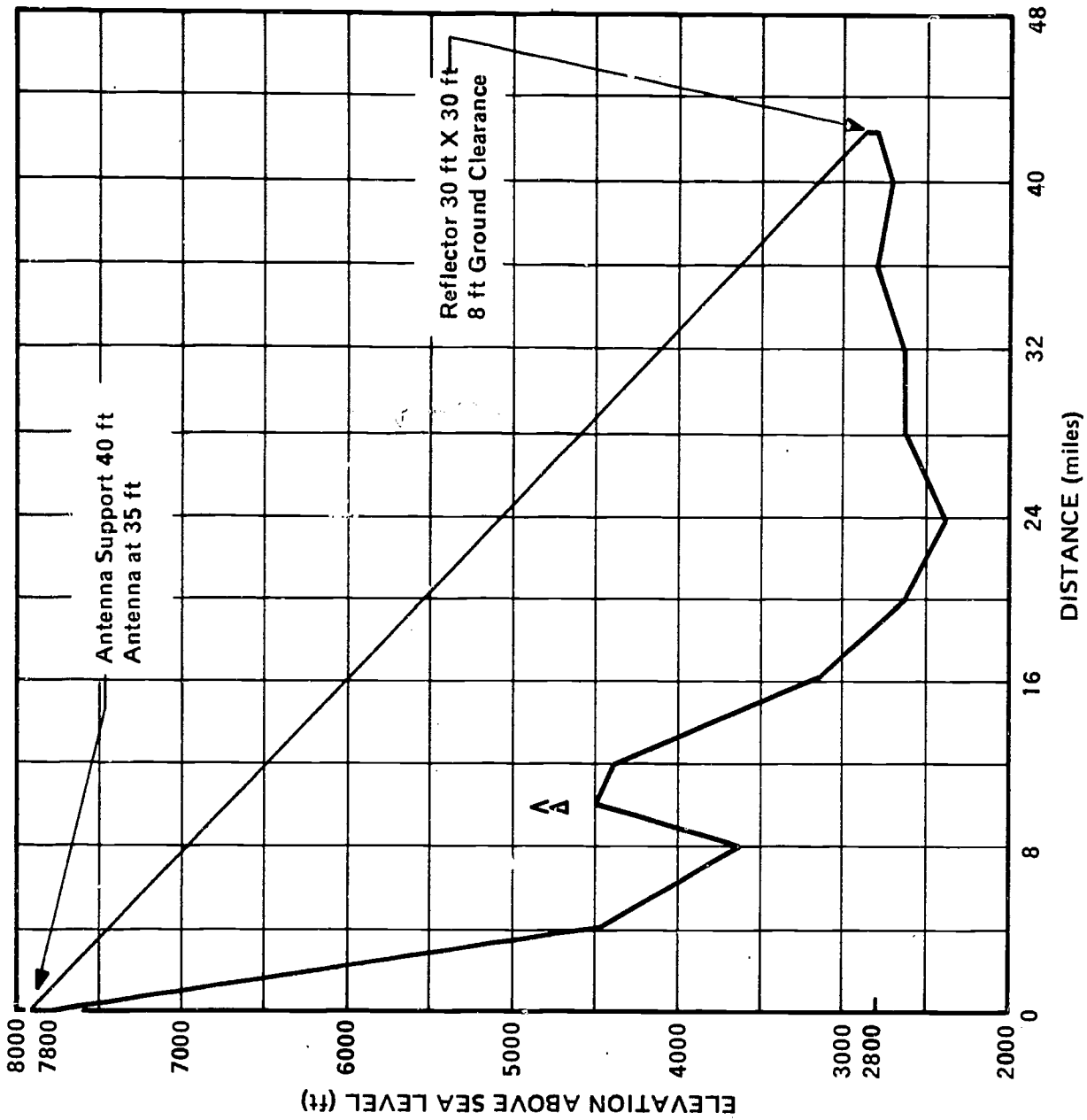

Figure A.3. Microwave Path Profile, Pinal Peak to Bylas Reflector.

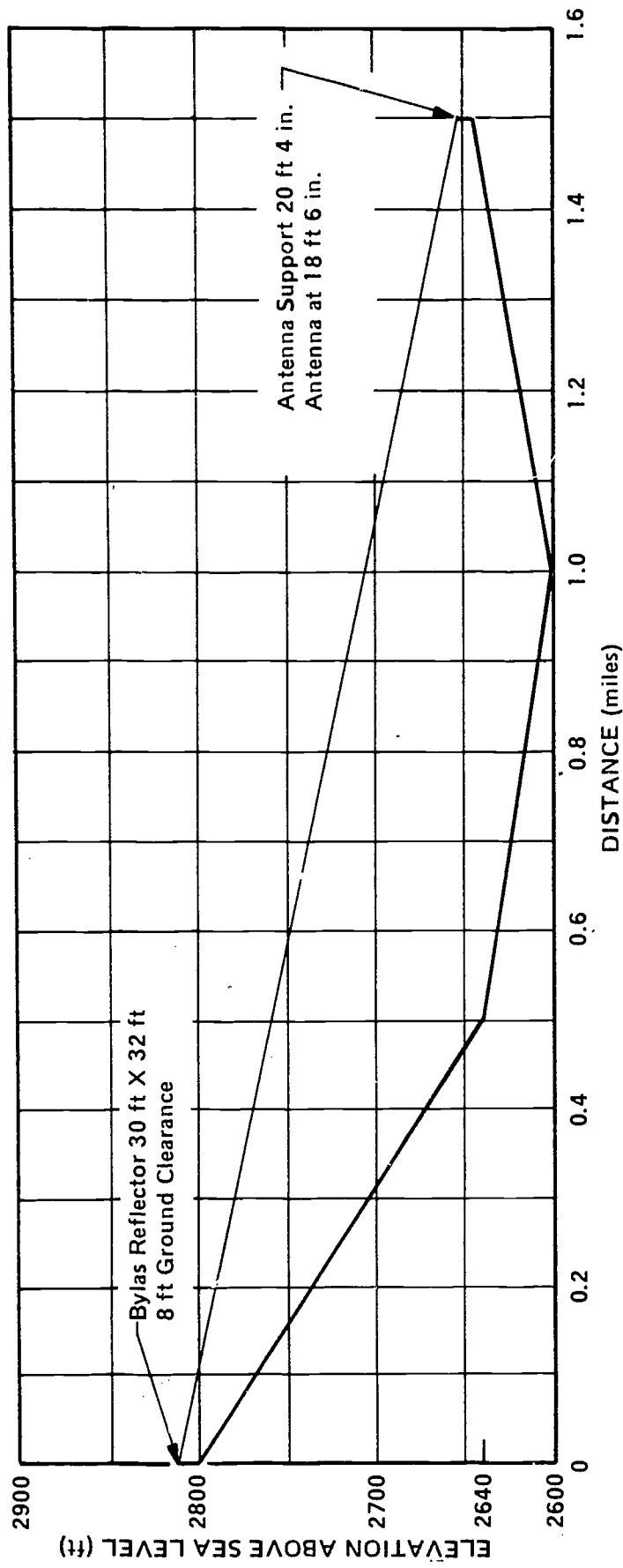

Figure A.4. Microwave Path Profile, Bylas Reflector to Bylas.

APPENDIX B

SITE MAPS

B-1

page A-6 is blank

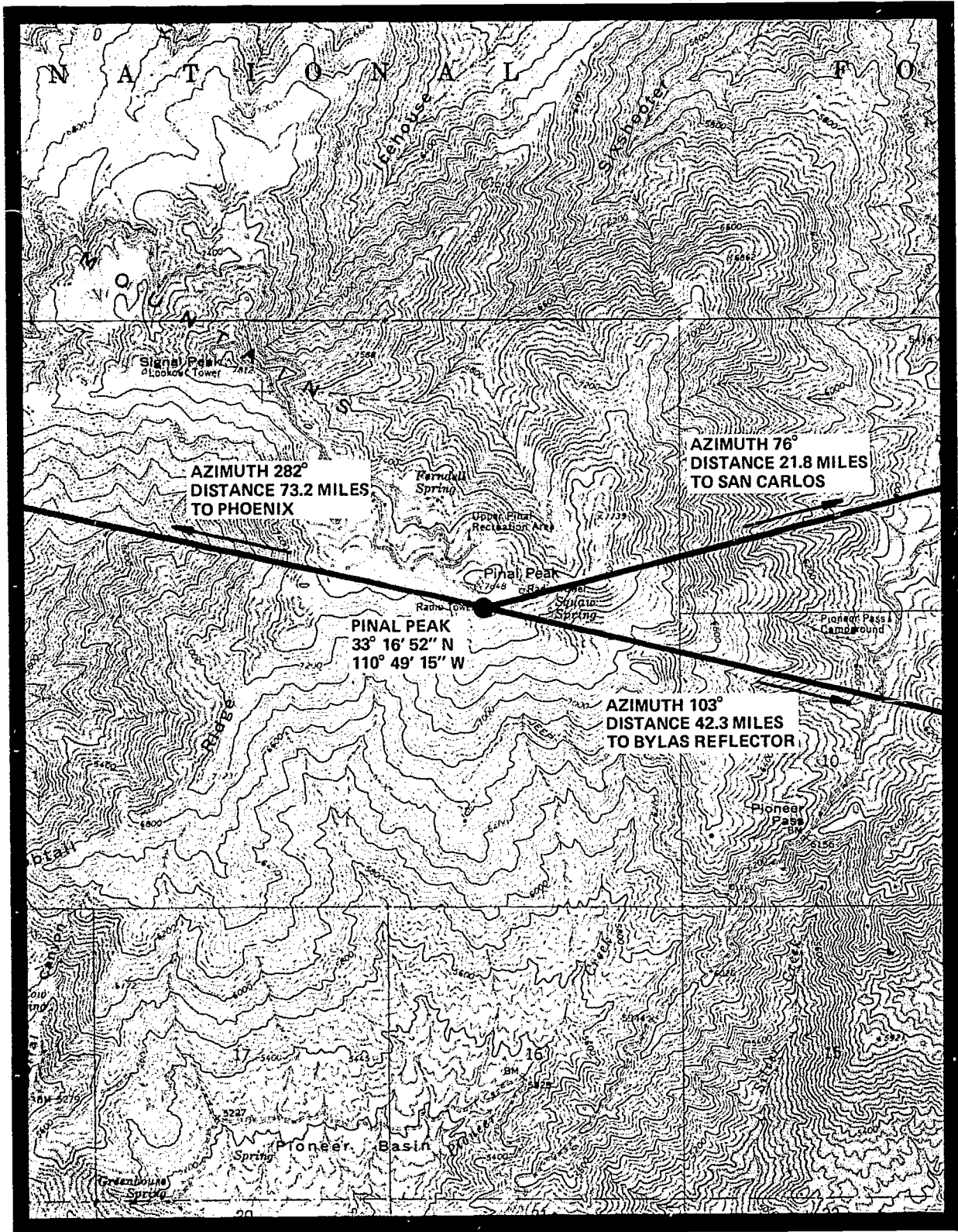

Figure B.2. Pinal Peak Site Map.

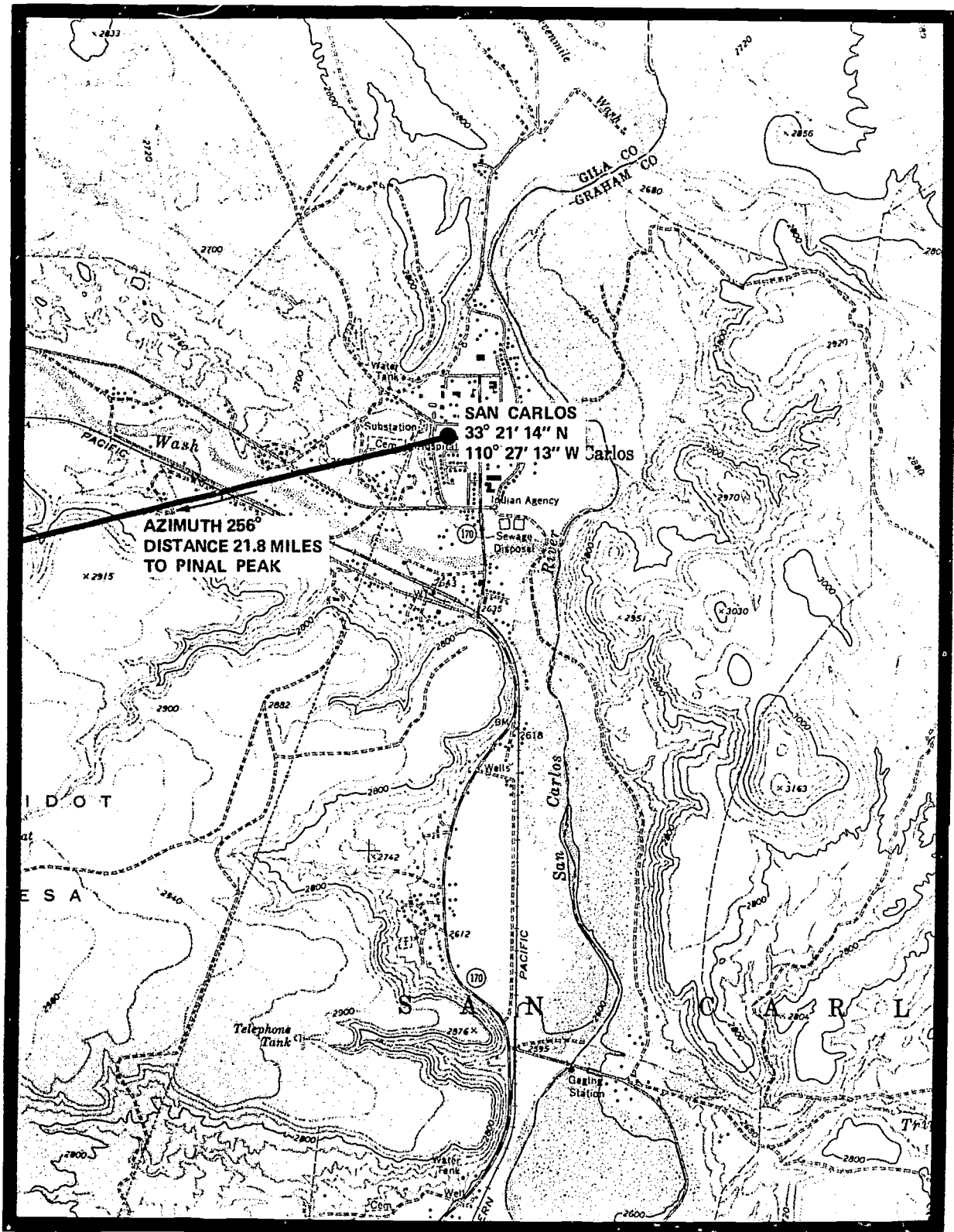

Figure B.3. San Carlos Site Map.

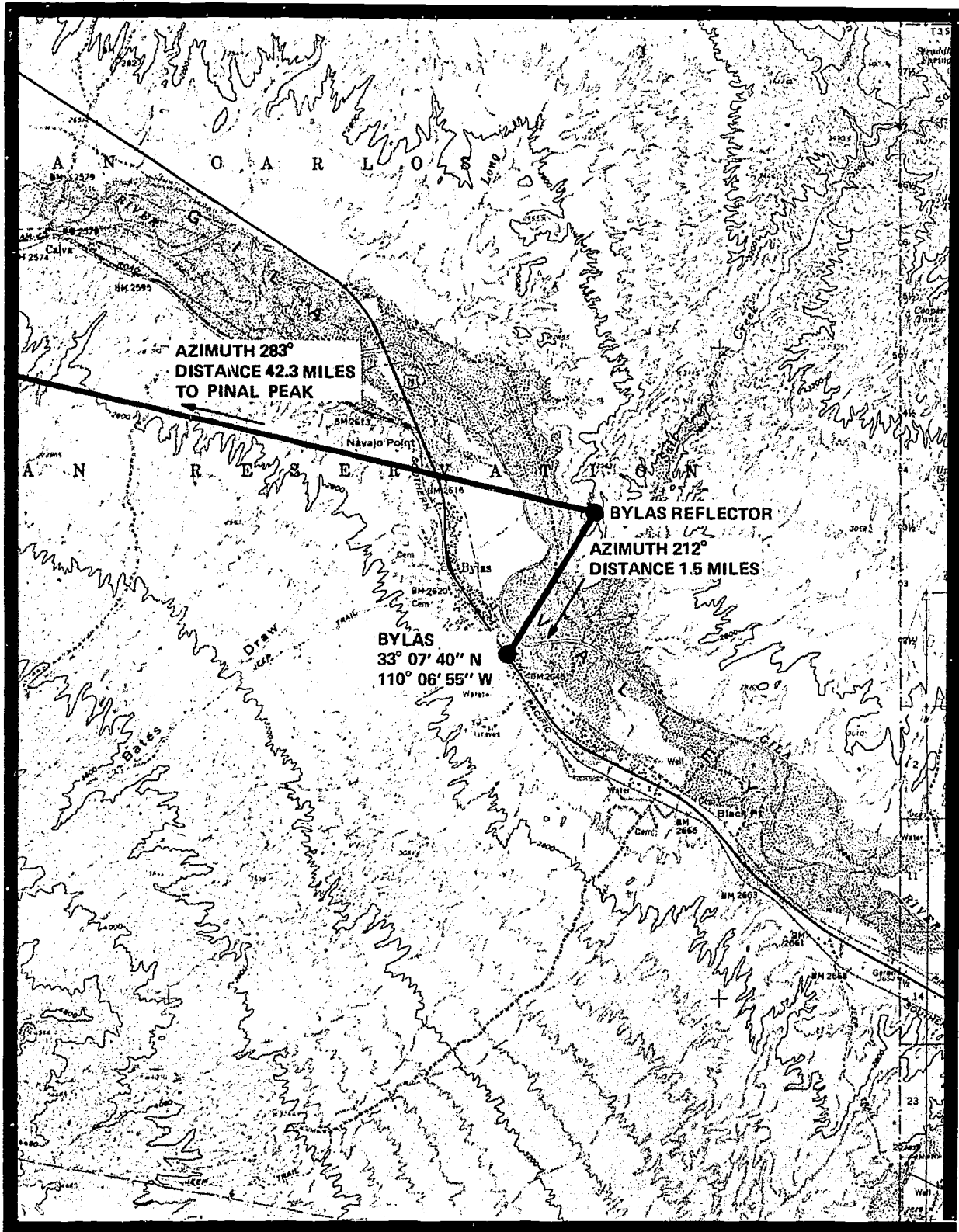

Figure B.4. Bylas and Bylas Reflector Site Map.

APPENDIX C

SITE PHOTOGRAPHS

B-6 is blank

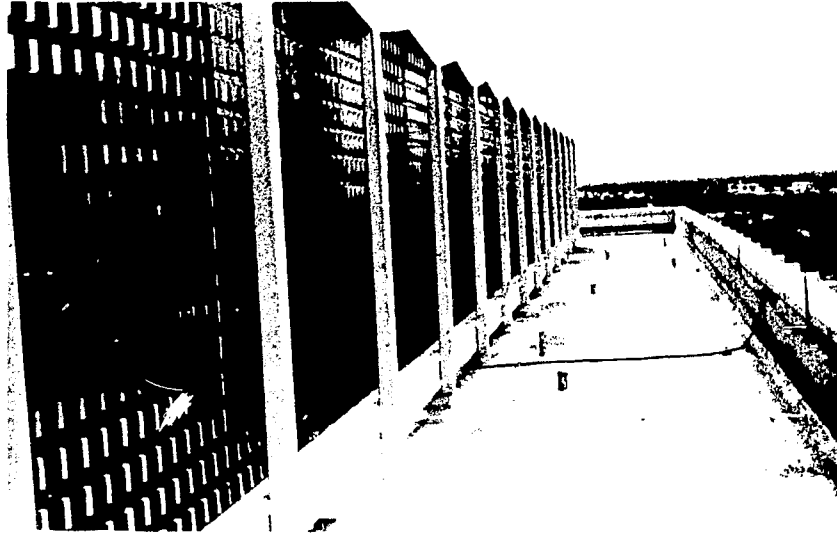

Figure C.1. Phoenix Indian Medical Center Roof Showing Lightning Rod Ground System and Grillwork Surrounding the Penthouse.



Figure C.2. Phoenix Indian Medical Center Roof Area Adjacent to Penthouse, Site of Proposed Prefabricated Equipment Shelter. Air Duct Shown in Center.

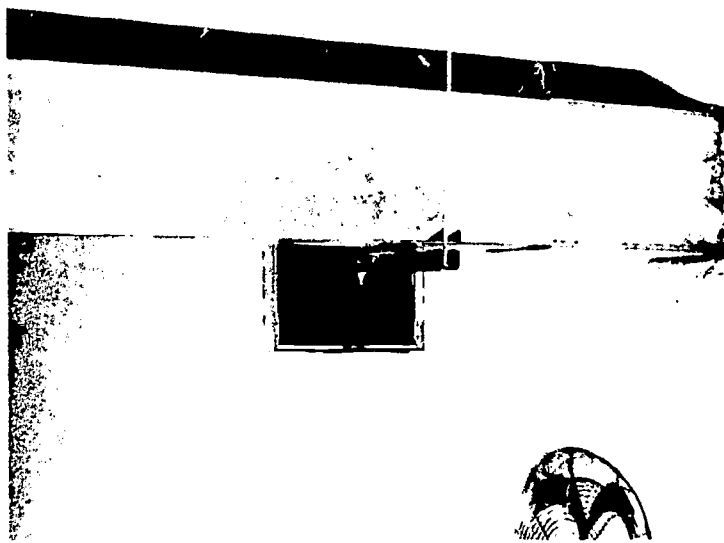

Figure C.3. Phoenix Indian Medical Center, Elevator Equipment Room Showing Proposed Cable Route from Elevator Shaft (access hole seen in center of photo) Paralleled with Existing Duct thru Outer Wall (to the right).

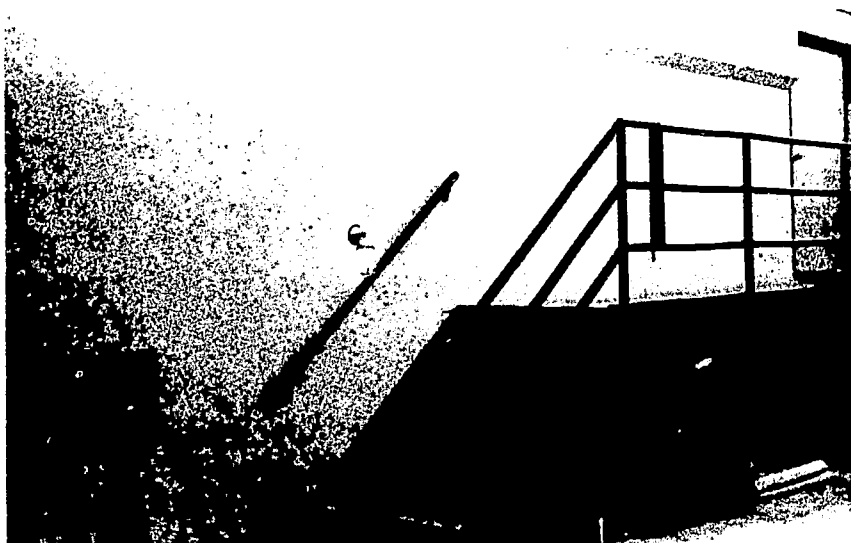

Figure C.4. Phoenix Indian Medical Center, Exterior View of Elevator Equipment Room, Showing Cable Feedthru Near Duct Port, Lower Left.

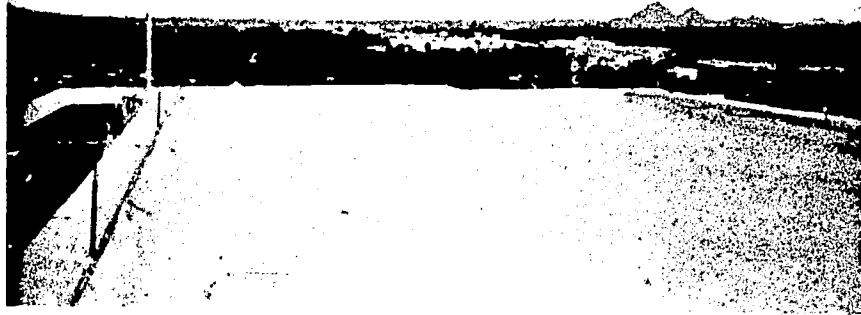

Figure C.5. Phoenix Indian Medical Center Elevator Equipment Room Roof. View Looking West. Top of Penthouse.



Figure C.6. Phoenix Indian Medical Center Showing Approximate Location of Proposed Control Console.

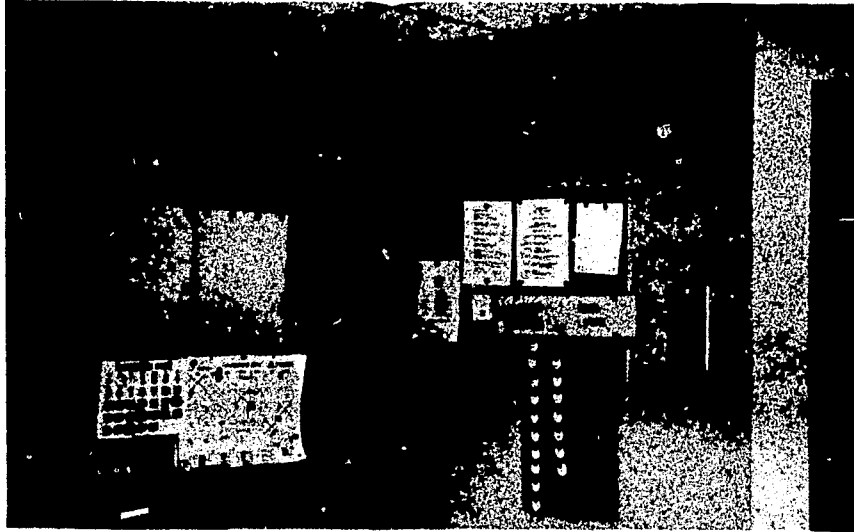

Figure C.7. Phoenix Indian Medical Center, Showing Proposed Monitor and Camera Mounting Positions.

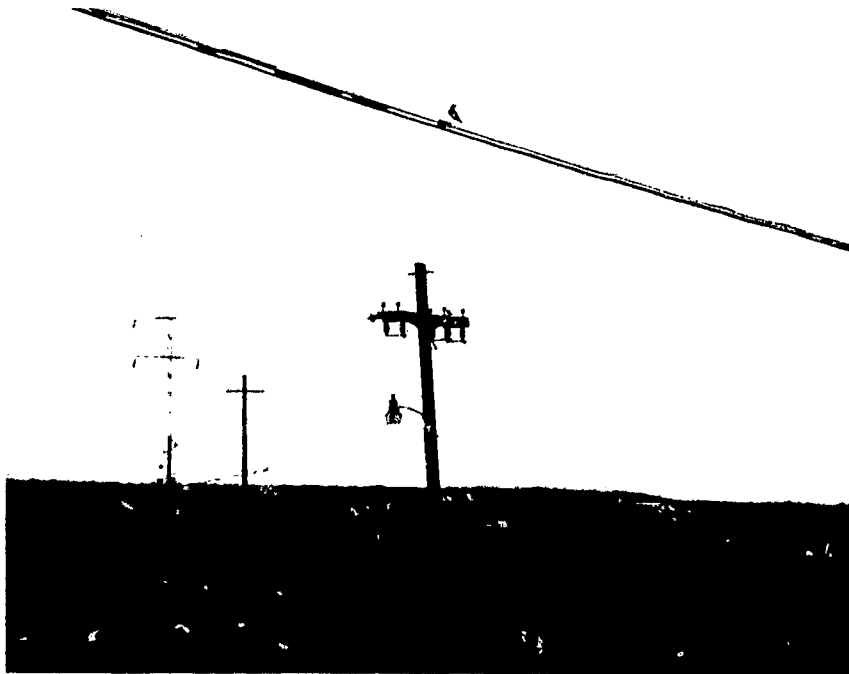

Figure C.8. Pinal Peak, Viewed from San Carlos.

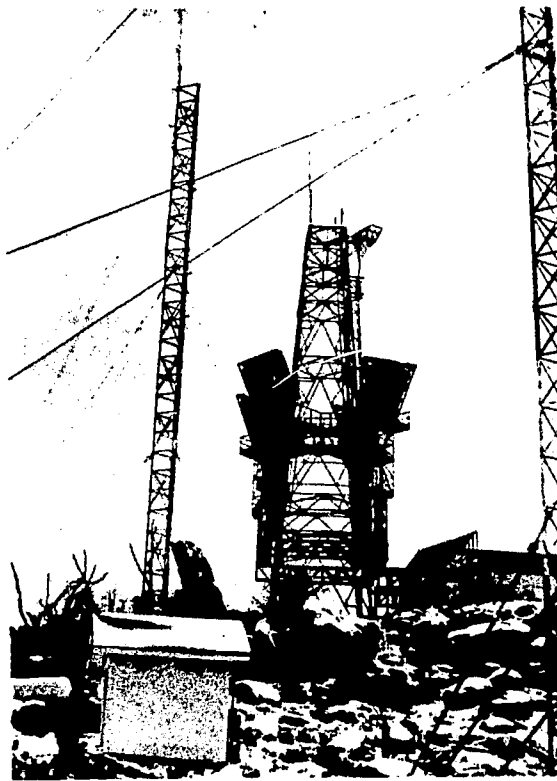

Figure C.9. Pinal Peak B.I.A. Radio Station (foreground left of center).

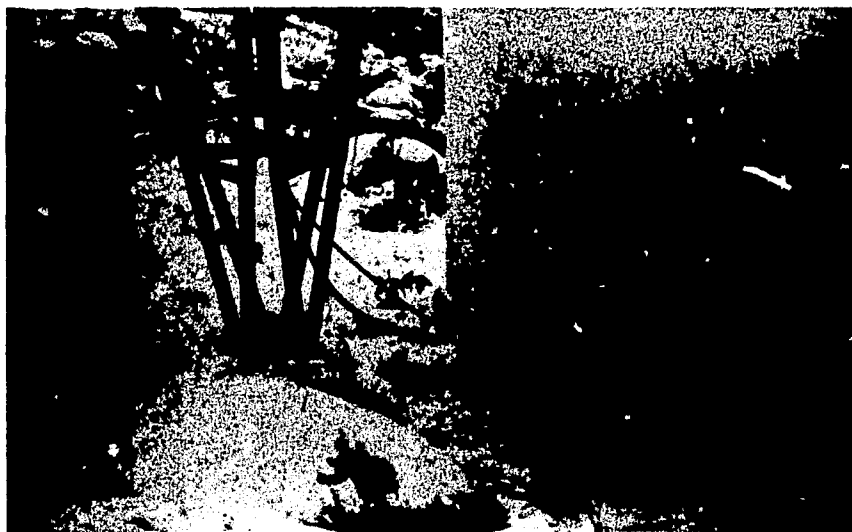

Figure C.10. Pinal Peak, Showing Existing Tower Base and Feedthru for Transmission Line.

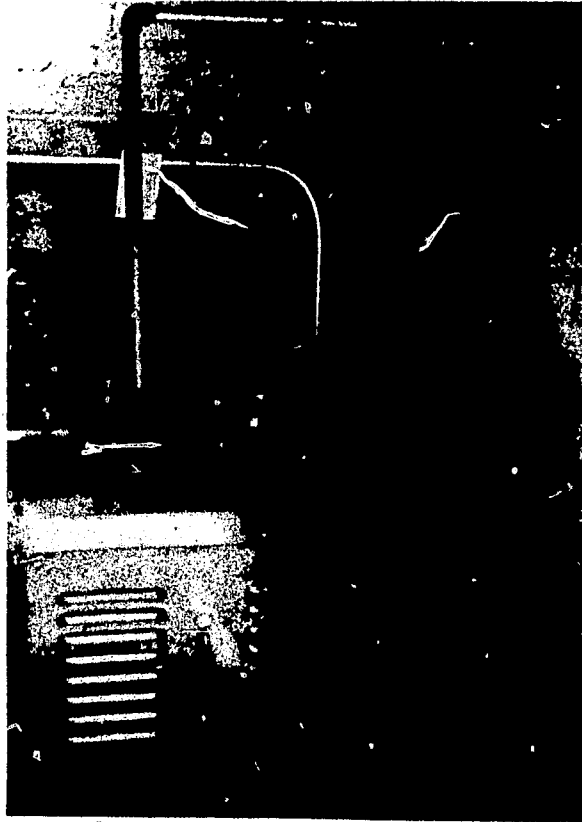

Figure C.11. Pinal Peak Showing the Interior of the Existing B.I.A. Equipment Shelter and Generator (to be removed).

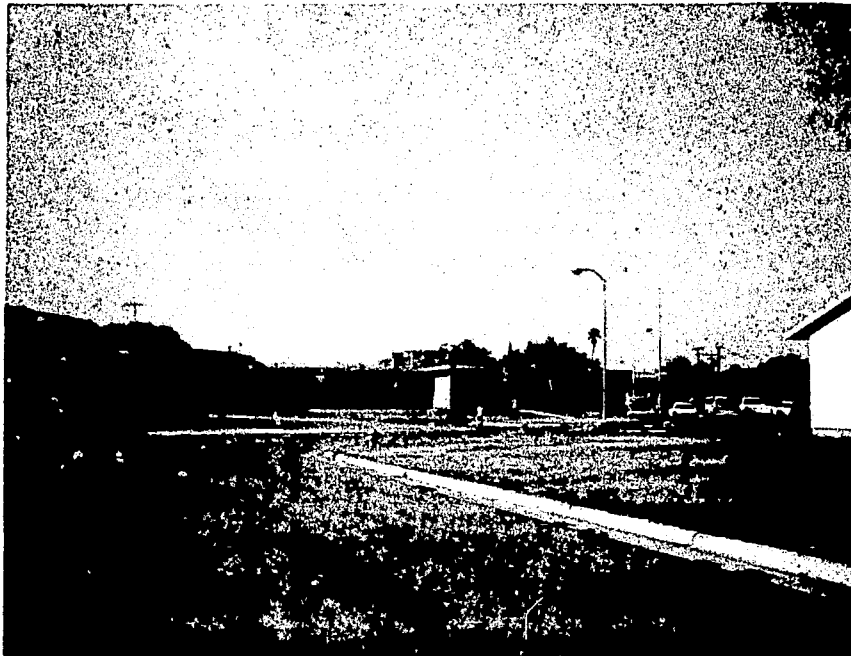

Figure C.12. San Carlos I.H.S. Hospital View Looking North.



Figure C.13. San Carlos I.H.S. Hospital, Corner of Building Nearest to Teleco Equipment Room and Where Tower is to be Located.



Figure C.14. San Carlos I.H.S. Hospital Showing Wall in the Teleco Equipment Room Where Proposed Microwave Equipment will be Flush Mounted.

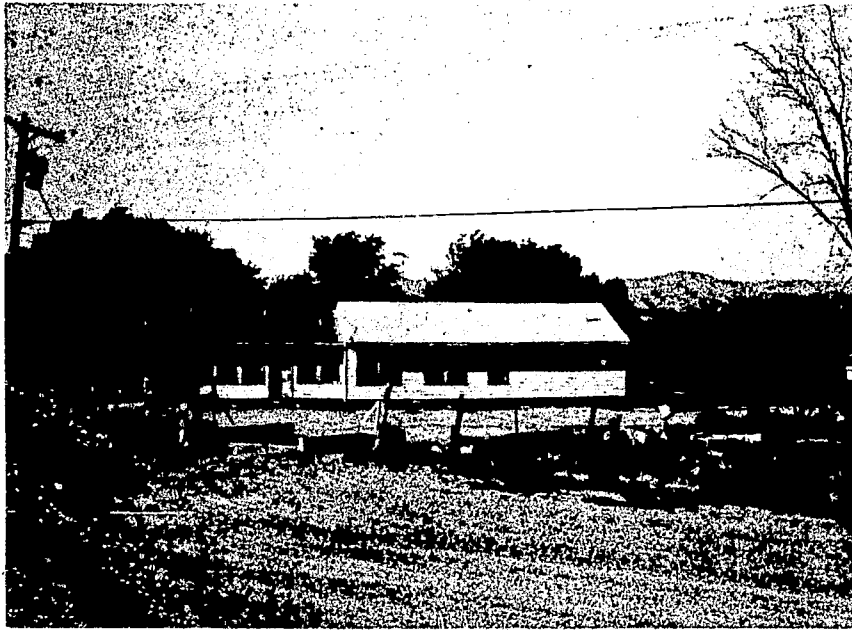

Figure C.15. Bylas, View to West from Grounds of the Clinic.



Figure C.16. Bylas Health Center Showing Approximate Site of Proposed Building Addition and Antenna Support.



Figure C.17. Bylas, View to West from Grounds of the Clinic.

APPENDIX D

DRAWINGS

D-1

127

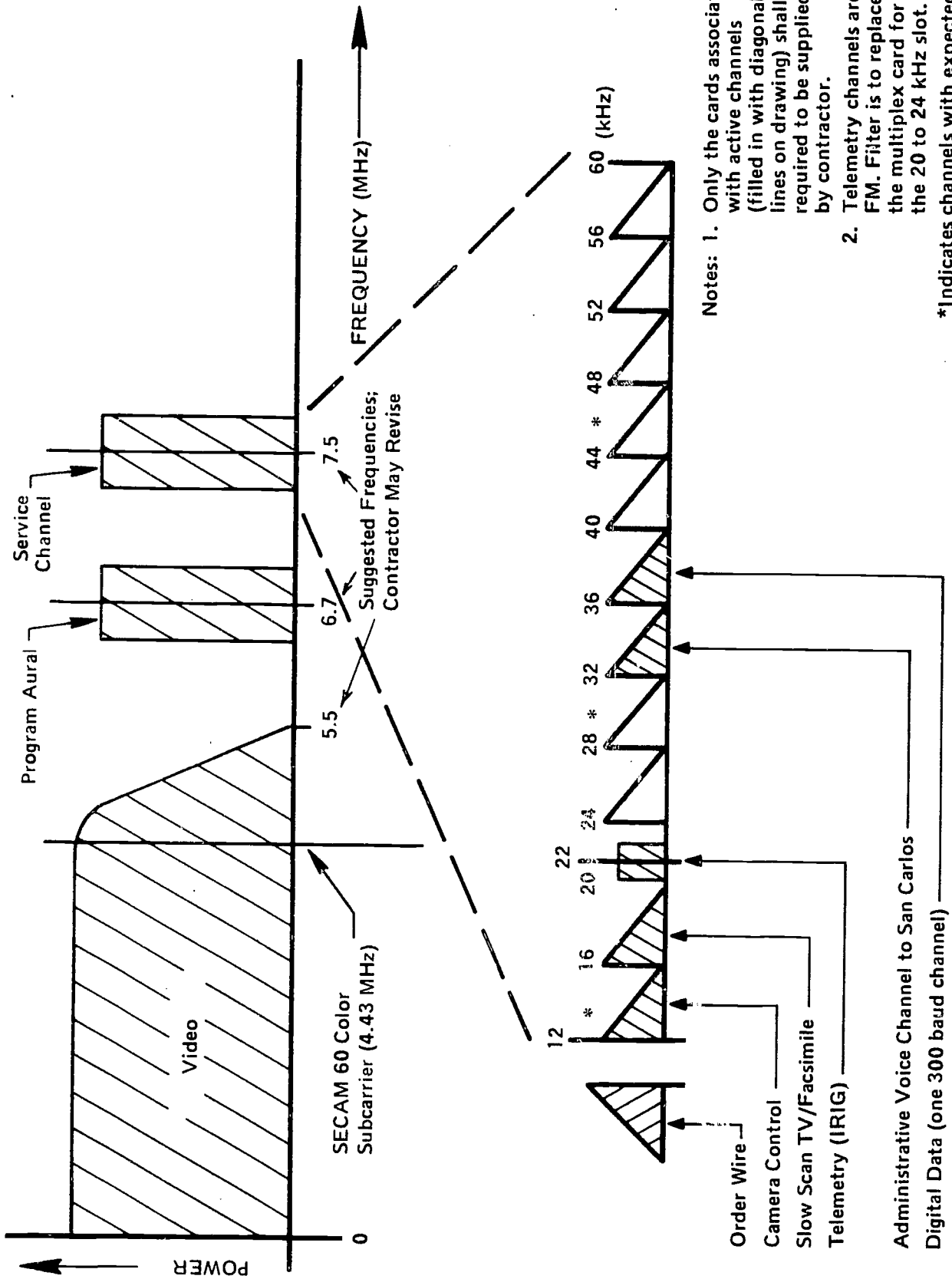
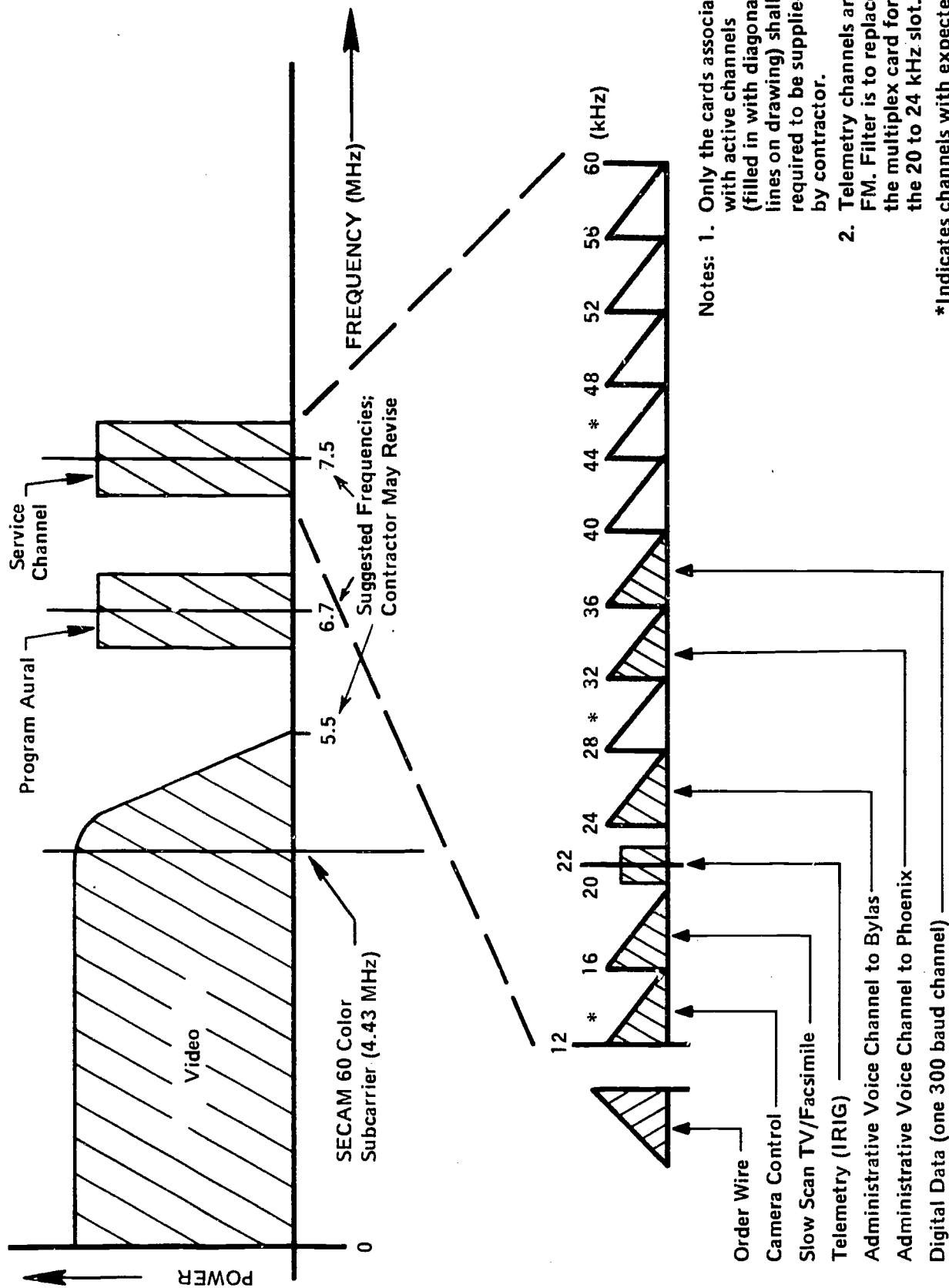
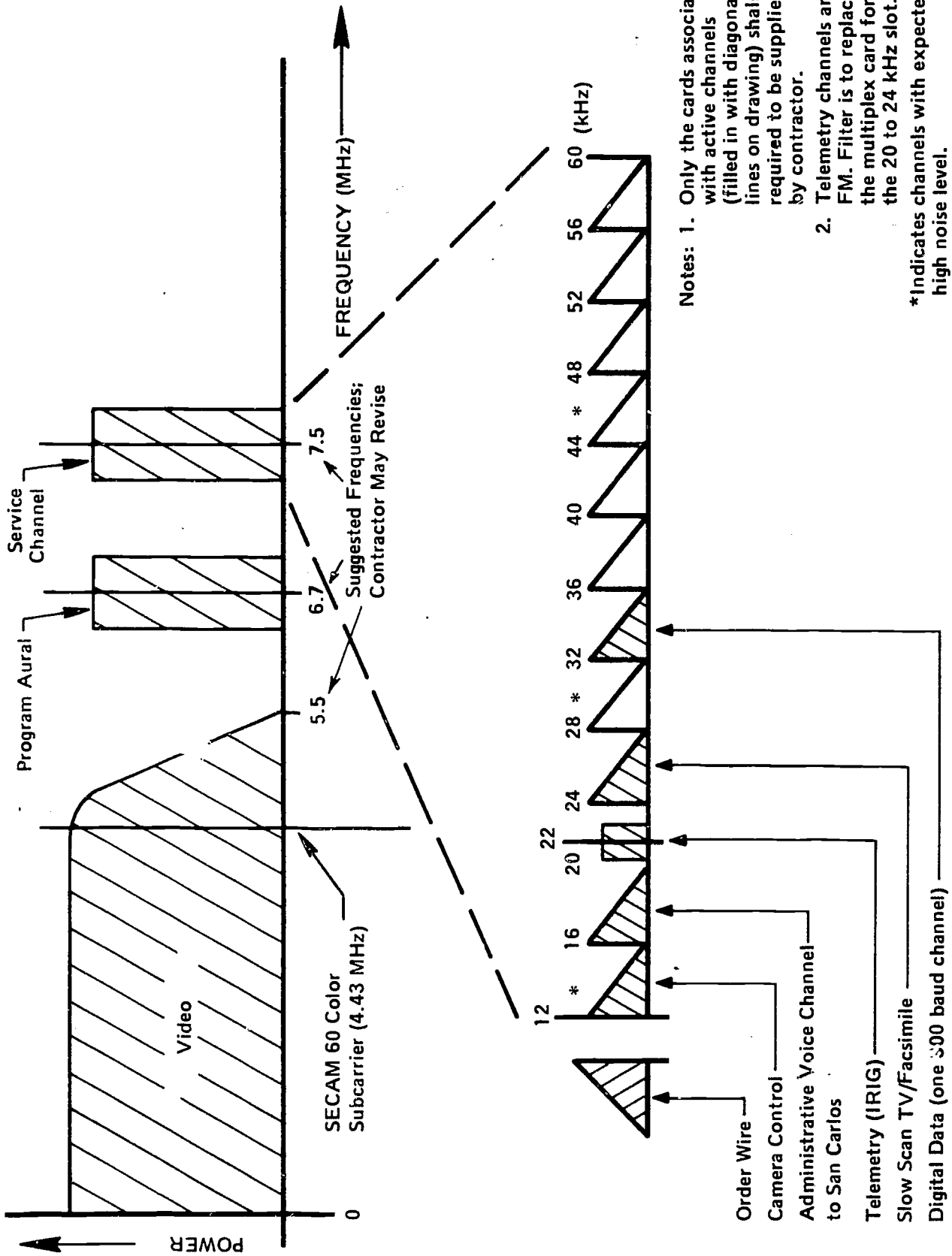

Figure D.1. Channelization Plan, Link from Phoenix to Pinal Peak.



- Notes:
1. Only the cards associated with active channels (filled in with diagonal lines on drawing) shall be required to be supplied by contractor.
 2. Telemetry channels are FM. Filter is to replace the multiplex card for the 20 to 24 kHz slot.
- *Indicates channels with expected high noise level.

Figure D.2. Channelization Plan, Link from San Carlos to Pinal Peak.



D-4

Figure D.3. Channelization Plan, Link from Bylas to Pinal Peak.

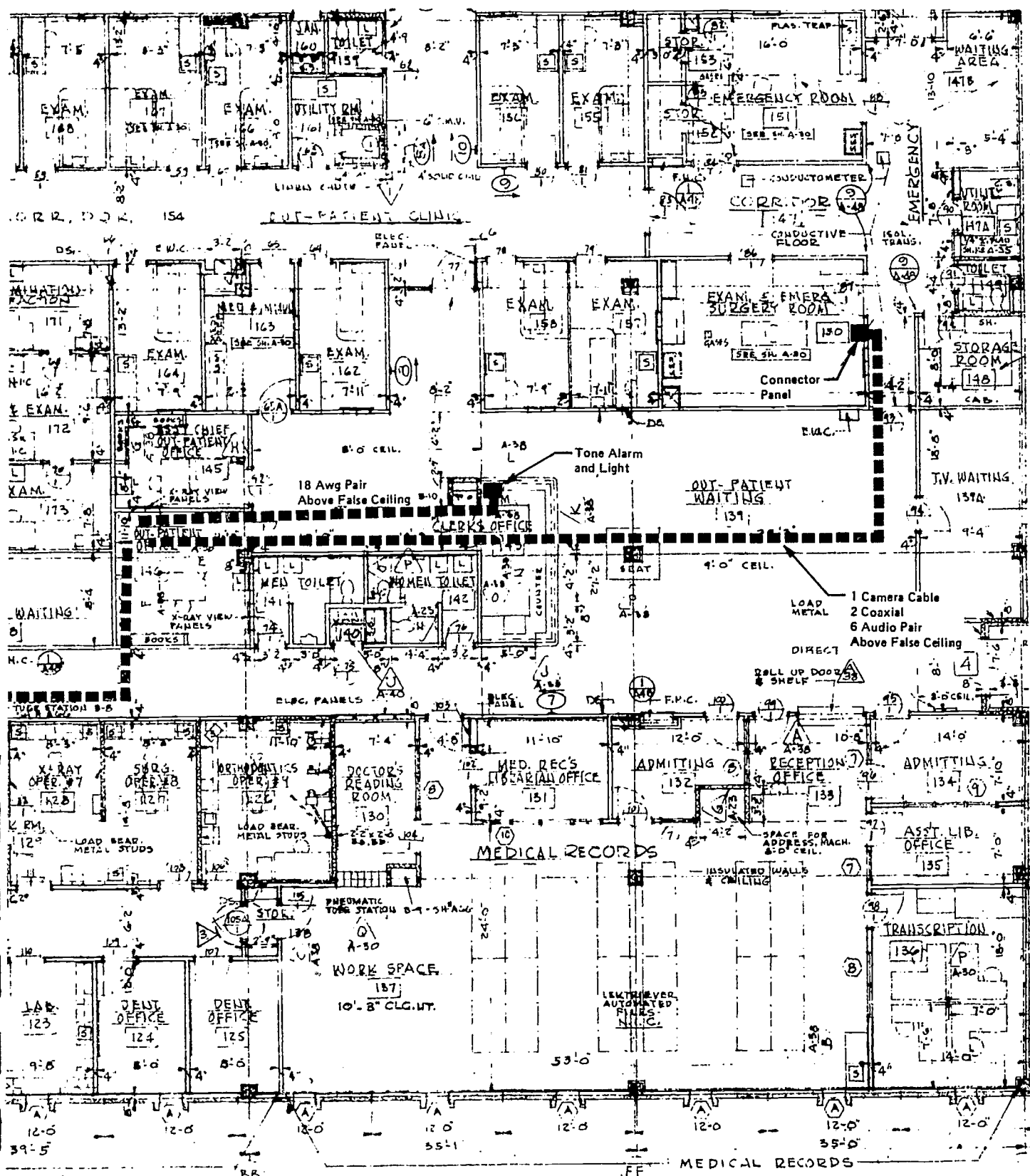

Note: Cable Requirement from First Floor to Penthouse Consists of Four Coaxial Cables Plus 12 Pairs.

Figure D.4. Existing and Proposed Facilities, Phoenix Indian Medical Center.



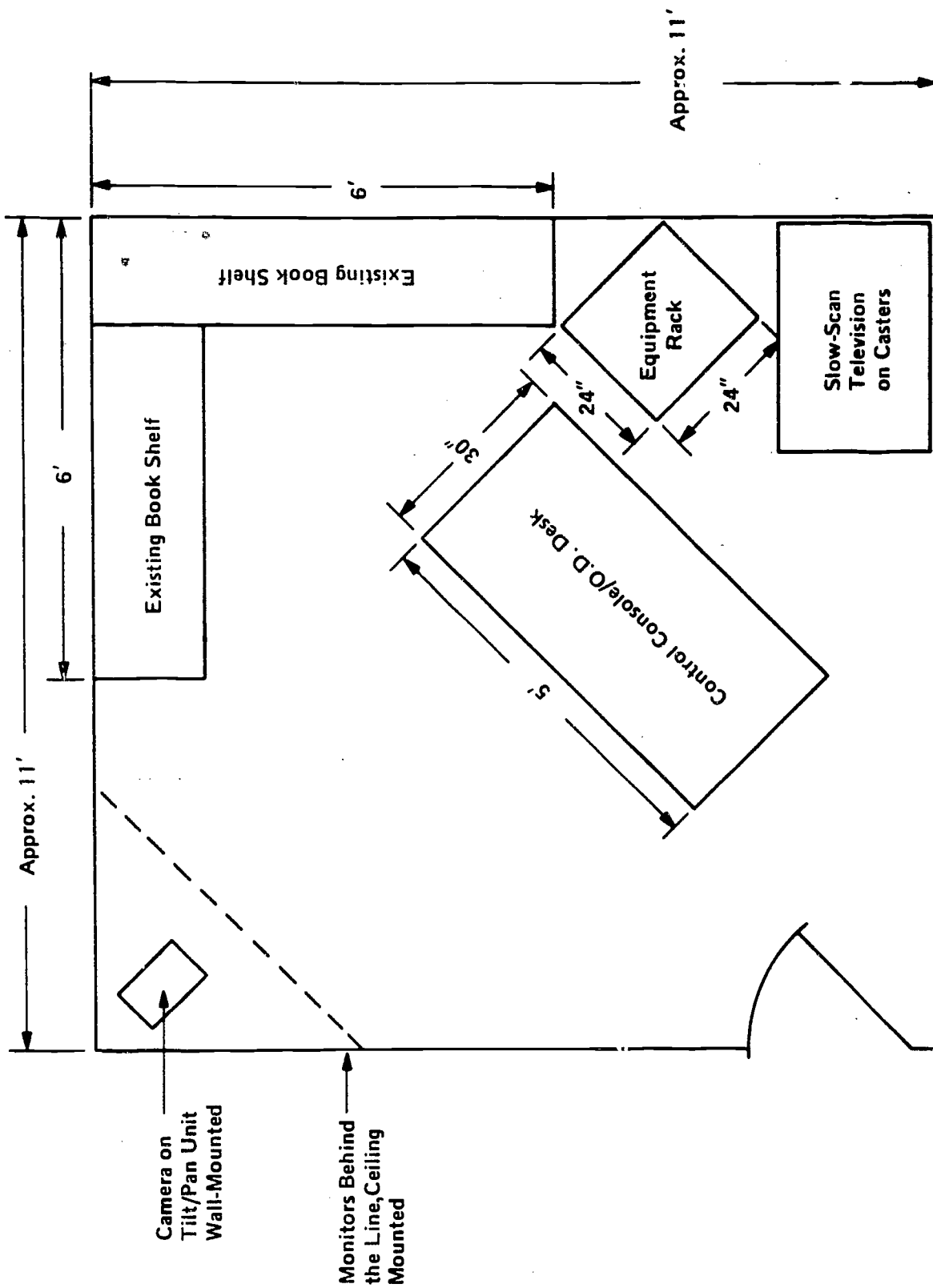

Note: Contractor to provide extra set of monitors on roll around pedestals. Contractor also to provide pedestal and manual cradle head for alternate mounting of camera.

Figure D.5. Approximate Equipment Locations, Phoenix Indian Medical Center, First Floor.

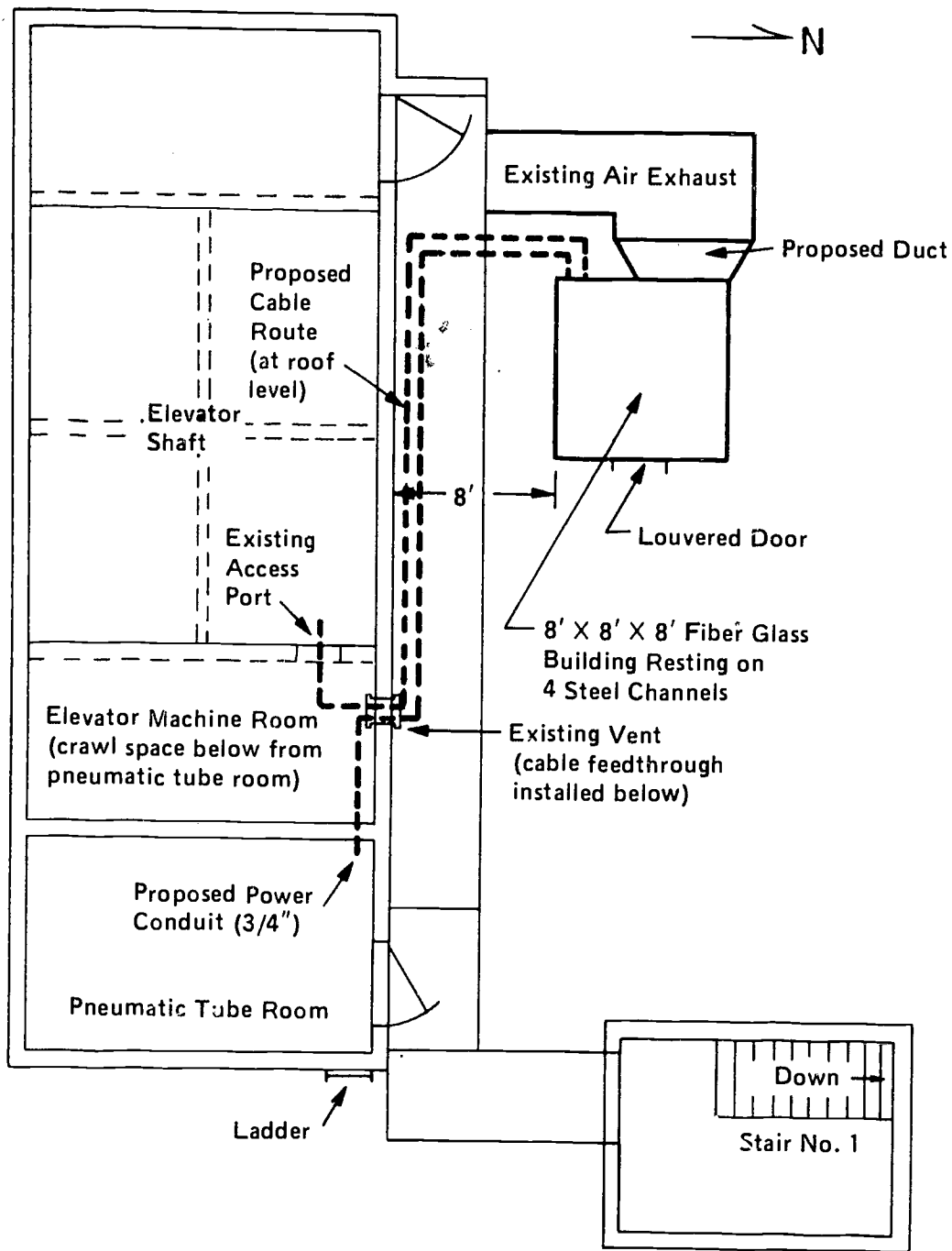

Notes:

1. Hospital to supply emergency and main power within the pneumatic tube room.
2. Cable vertical run in shaft to be secured to existing conduit.
3. Cable run consists of six coaxial cables.
4. Fiber glass prefab building to rest on four 4" X 6" X 1/4" steel channels: \square 4".
5. Existing exhaust air duct to be diverted through proposed equipment building.
6. Microwave dishes on 10' stub tower on roof above elevator machine room.

Figure D.6. Proposed Radio Facilities, Roof and Penthouse, Phoenix Indian Medical Center.

Hard Surface Road

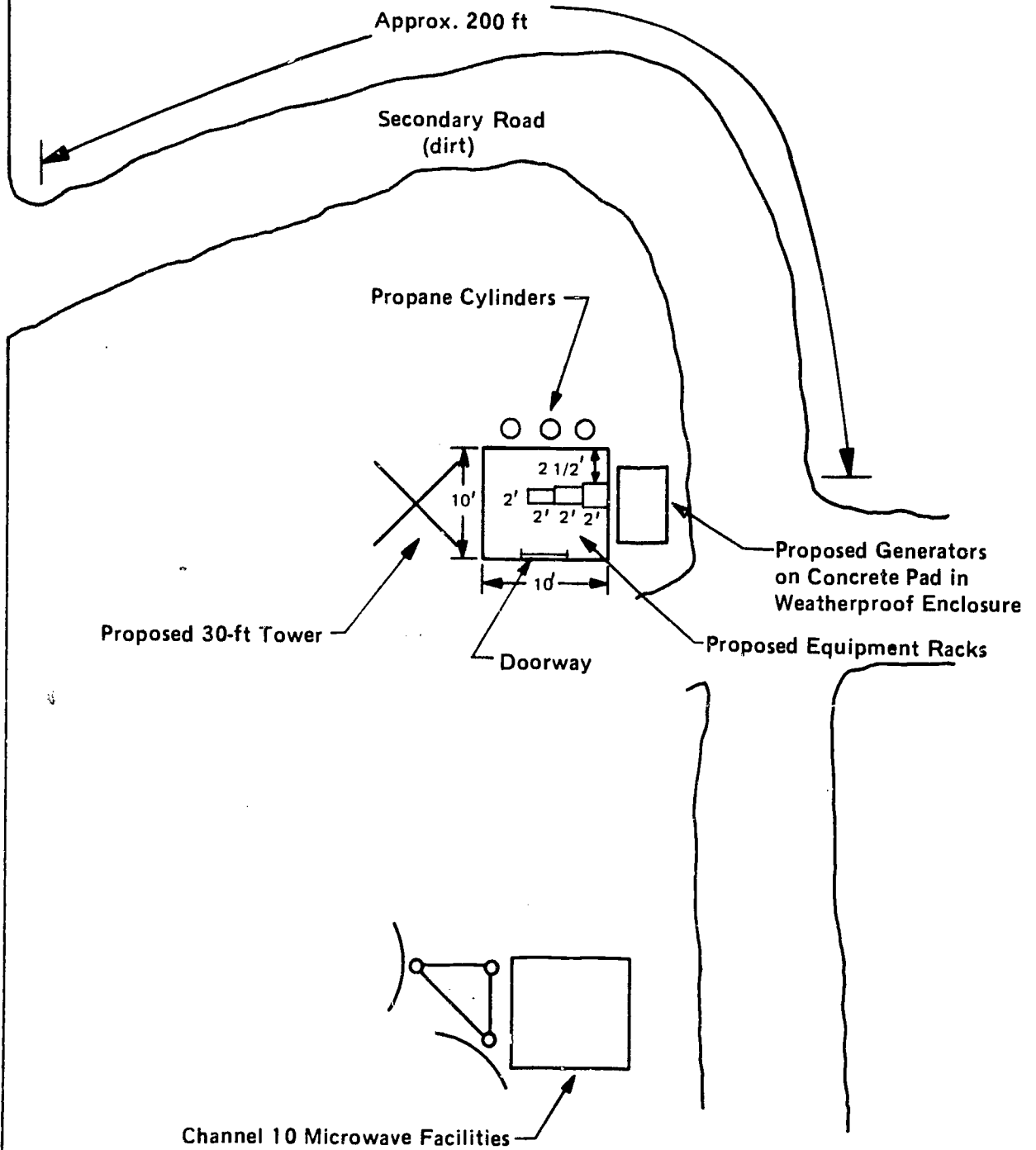

Note: Existing tower and generator must be removed. New tower will be located as shown. Existing VHF antennas shall be relocated thereon.

Figure D.7. Existing and Proposed Facilities, Pinal Peak.

D-9

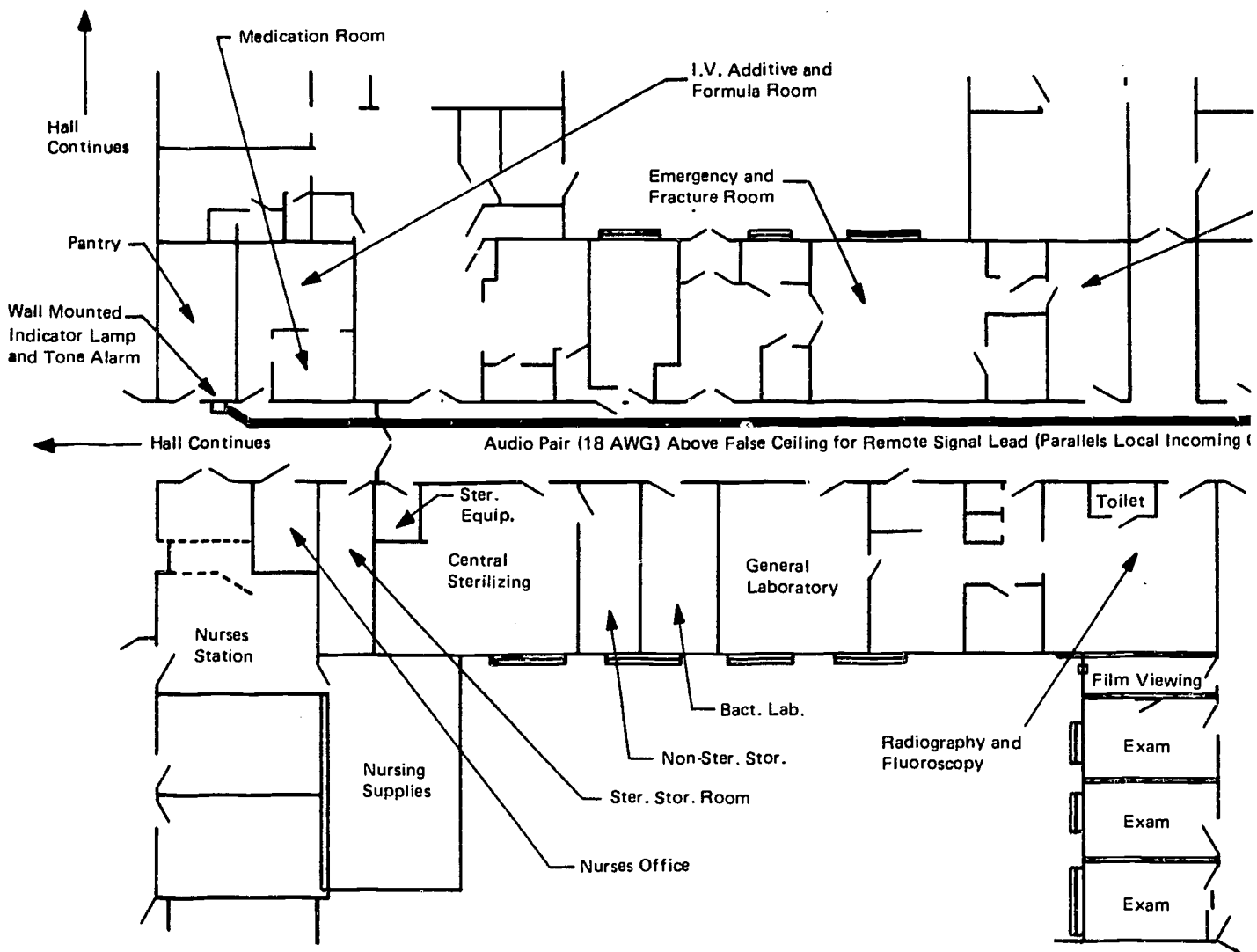

D-11

page D-10 is blank

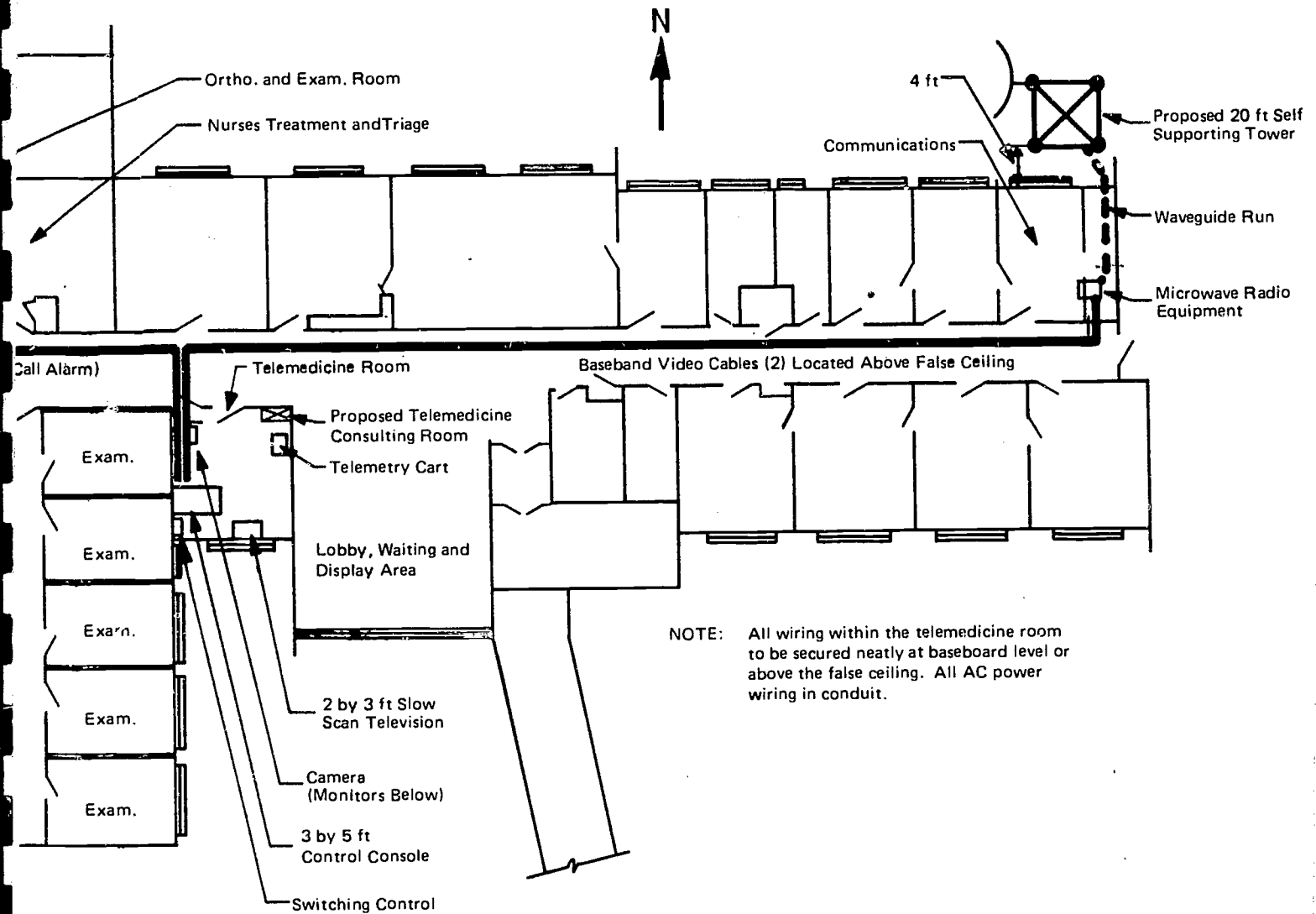

Figure D.8. Existing and Proposed Facilities, San Carlos Hospital.

d-12

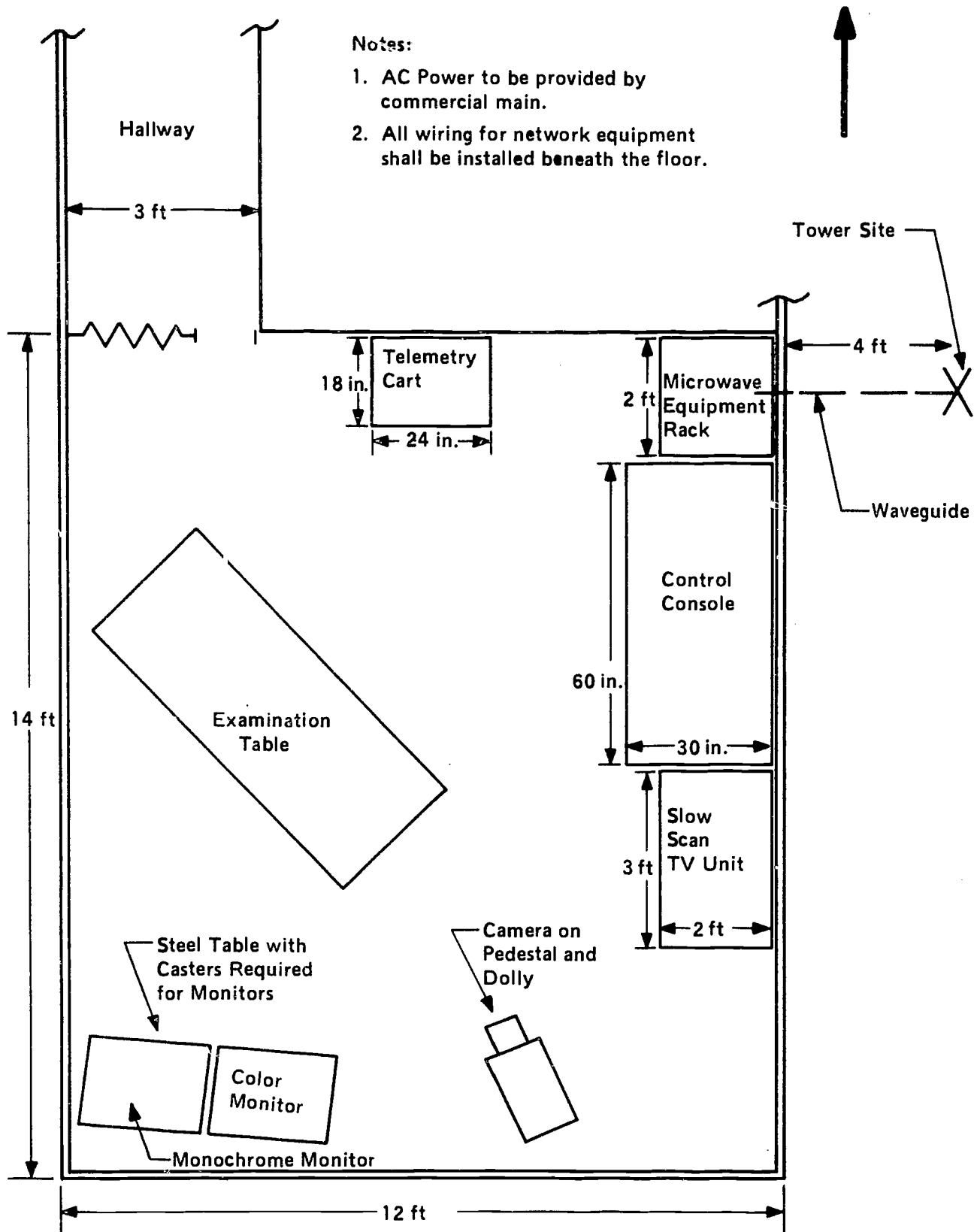

Figure D.9. Proposed Facilities, Bylas Field Health Station.

VIDEO SWITCHING CONTROL

LOCAL MATRIX

RESET	PINAL PEAK TO PHOENIX	
RESET	PHOENIX TO PINAL PEAK	
RESET		

PINAL PEAK MATRIX

RESET					
RESET		PHOENIX TO SAN CARLOS			
RESET		PHOENIX TO BYLAS			
RESET	SAN CARLOS TO PHOENIX	BYLAS TO PHOENIX			
RESET					
RESET					

SLOW-SCAN TV SWITCHING CONTROL

LOCAL MATRIX

RESET	PINAL PEAK TO PHOENIX	
RESET	PHOENIX TO PINAL PEAK	
RESET		

PINAL PEAK MATRIX

RESET				
RESET		PHOENIX TO SAN CARLOS		
RESET		PHOENIX TO BYLAS		
RESET	SAN CARLOS TO PHOENIX	BYLAS TO PHOENIX		

16"

48"

16"

D-15
139

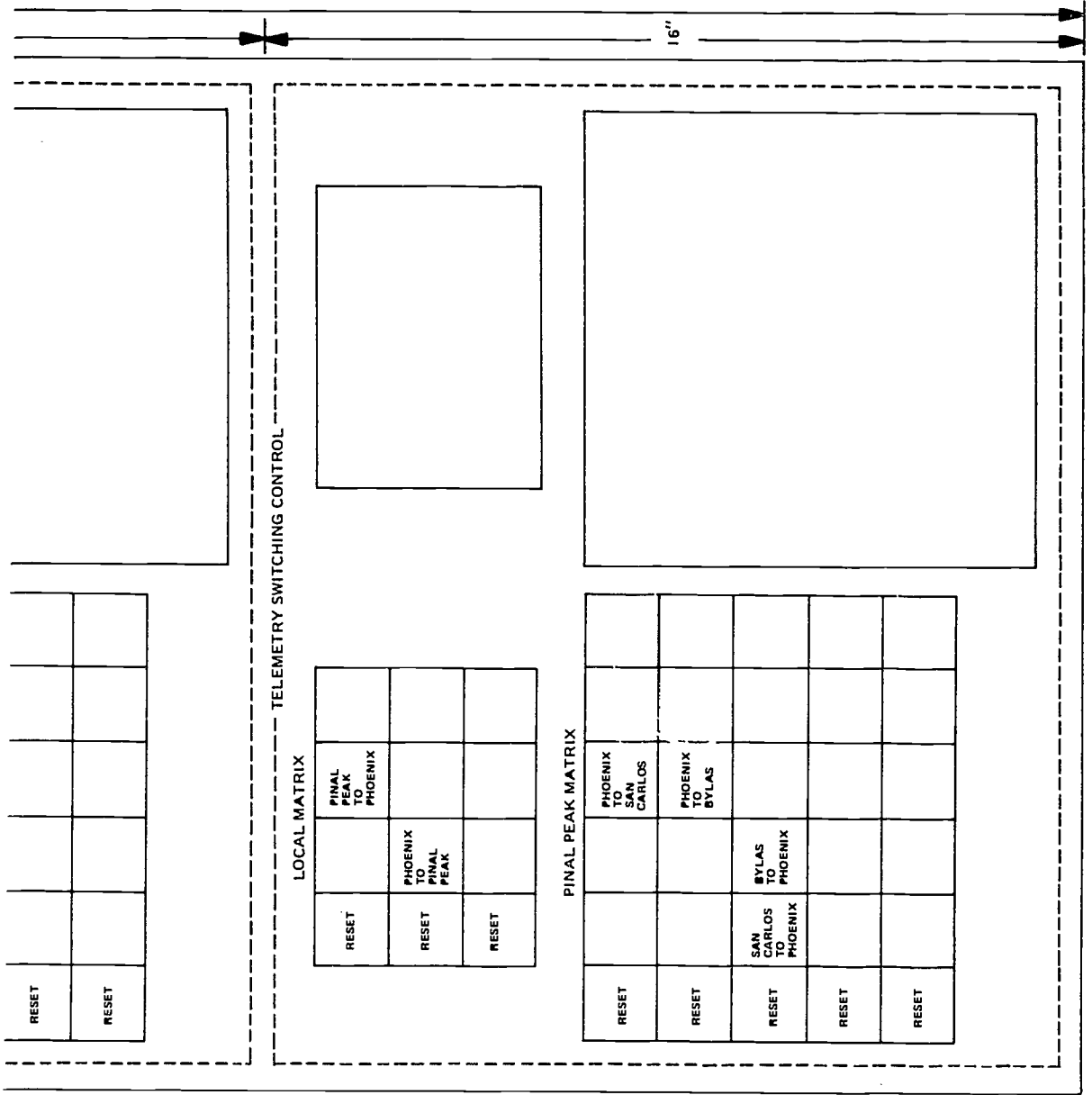

Note: All push button to be rear illuminated type with designations as indicated above engraved thereon. Panel is to be finished in blue. Lettering and dashed lines are to be painted in white. Panel to be hinged at left to swing out for maintenance.

Figure D.10. Switching Control Panel Layout at Phoenix.

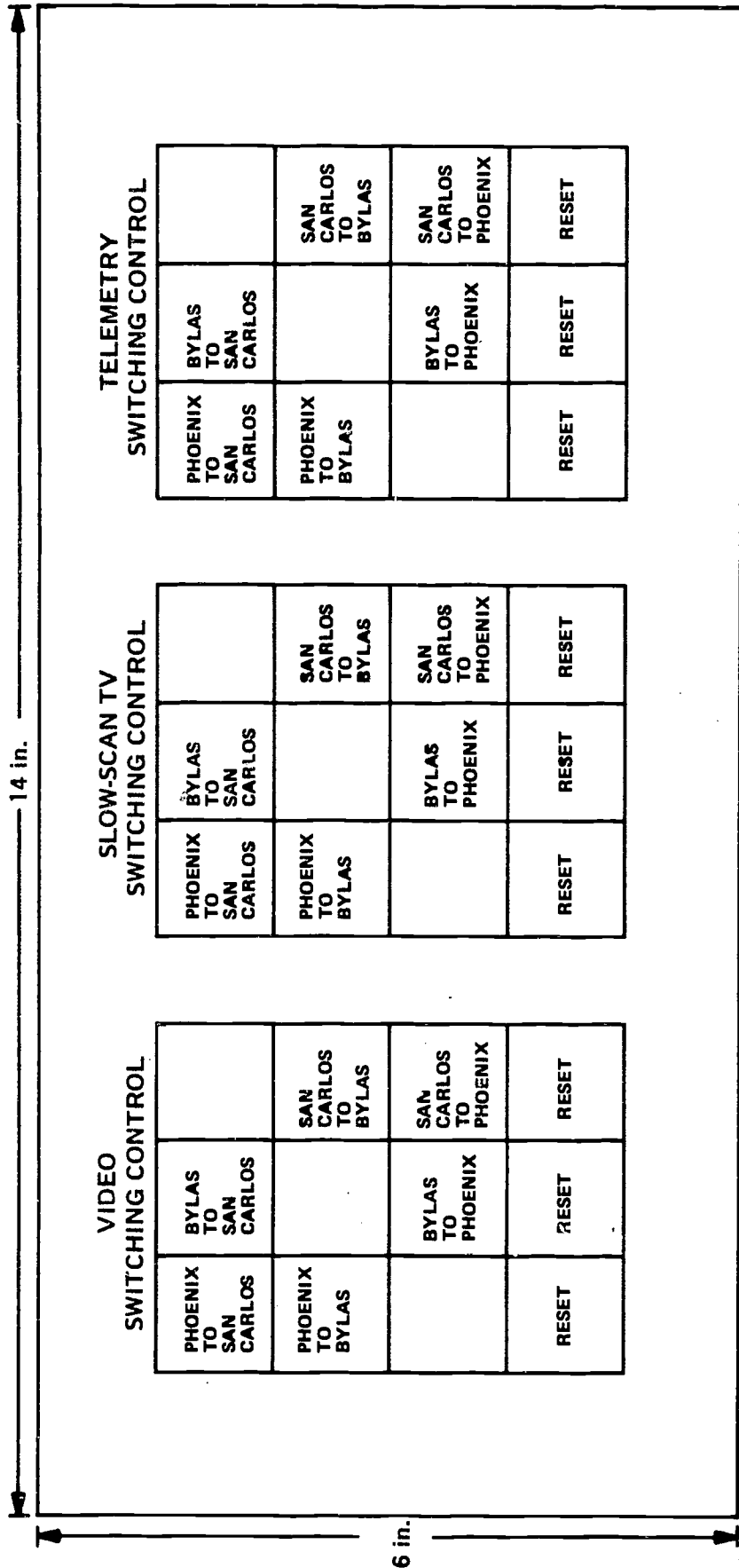

TELEMETRY SWITCHING CONTROL

PHOENIX TO SAN CARLOS	BYLAS TO SAN CARLOS	
PHOENIX TO BYLAS		SAN CARLOS TO BYLAS
RESET	BYLAS TO PHOENIX	SAN CARLOS TO PHOENIX
RESET	RESET	RESET

SLOW-SCAN TV SWITCHING CONTROL

PHOENIX TO SAN CARLOS	BYLAS TO SAN CARLOS	
PHOENIX TO BYLAS		SAN CARLOS TO BYLAS
RESET	BYLAS TO PHOENIX	SAN CARLOS TO PHOENIX
RESET	RESET	RESET

VIDEO SWITCHING CONTROL

PHOENIX TO SAN CARLOS	BYLAS TO SAN CARLOS	
PHOENIX TO BYLAS		SAN CARLOS TO BYLAS
RESET	BYLAS TO PHOENIX	SAN CARLOS TO PHOENIX
RESET	RESET	RESET

Figure D.11. San Carlos Switching Control Panel.

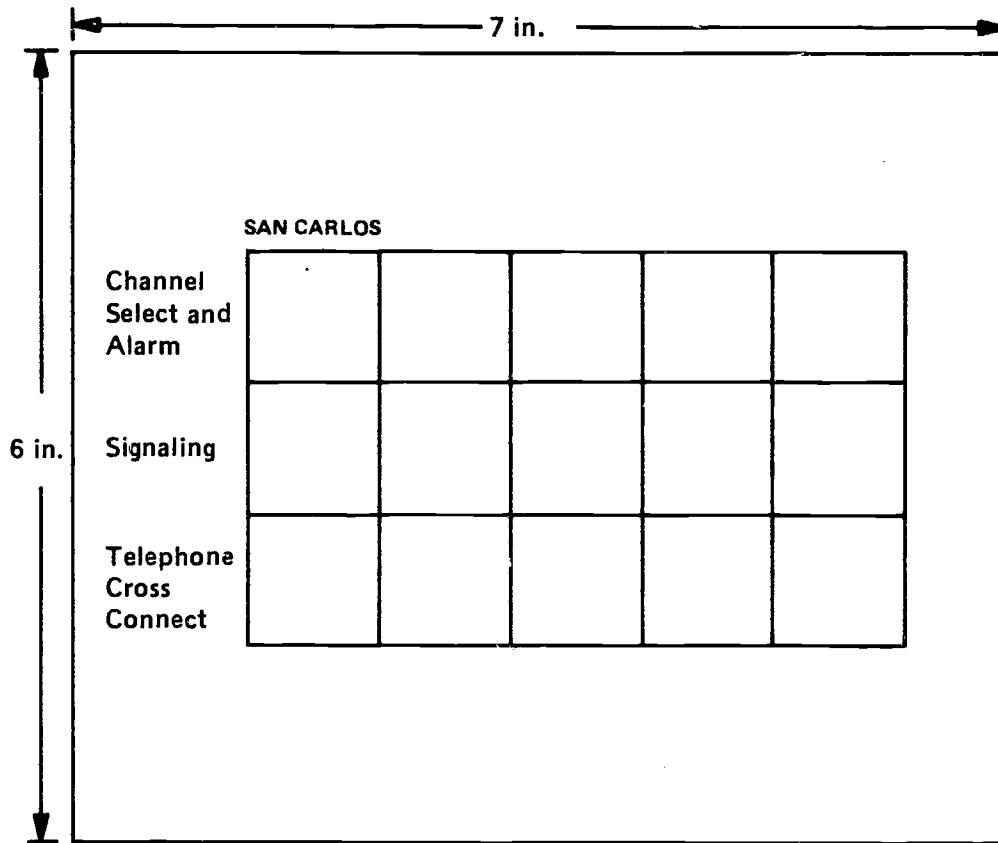

Figure D.12. AdVC Panel Layout at Phoenix.

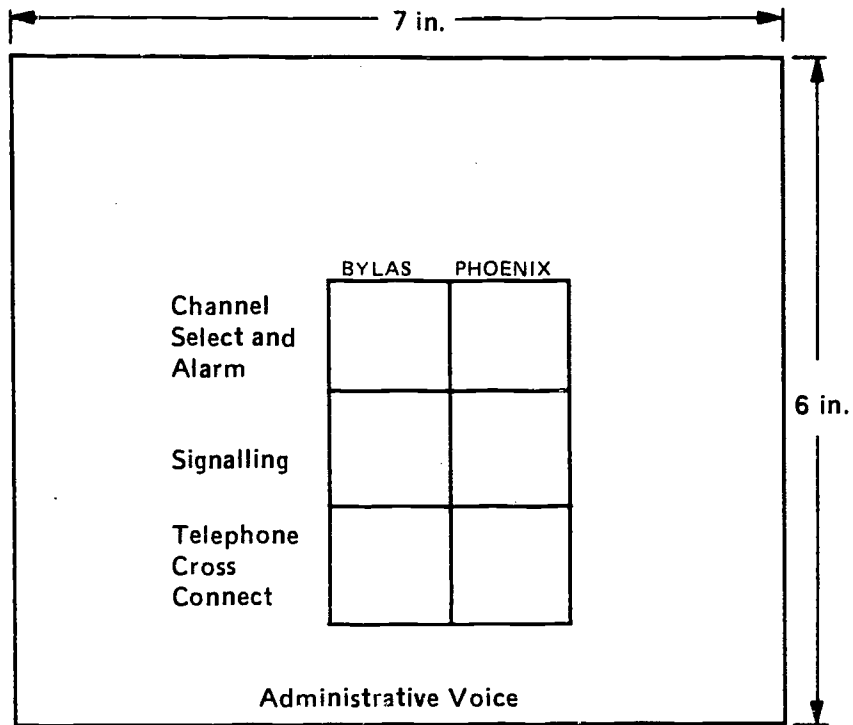

Figure D.13. AdVC Panel Layout, San Carlos.

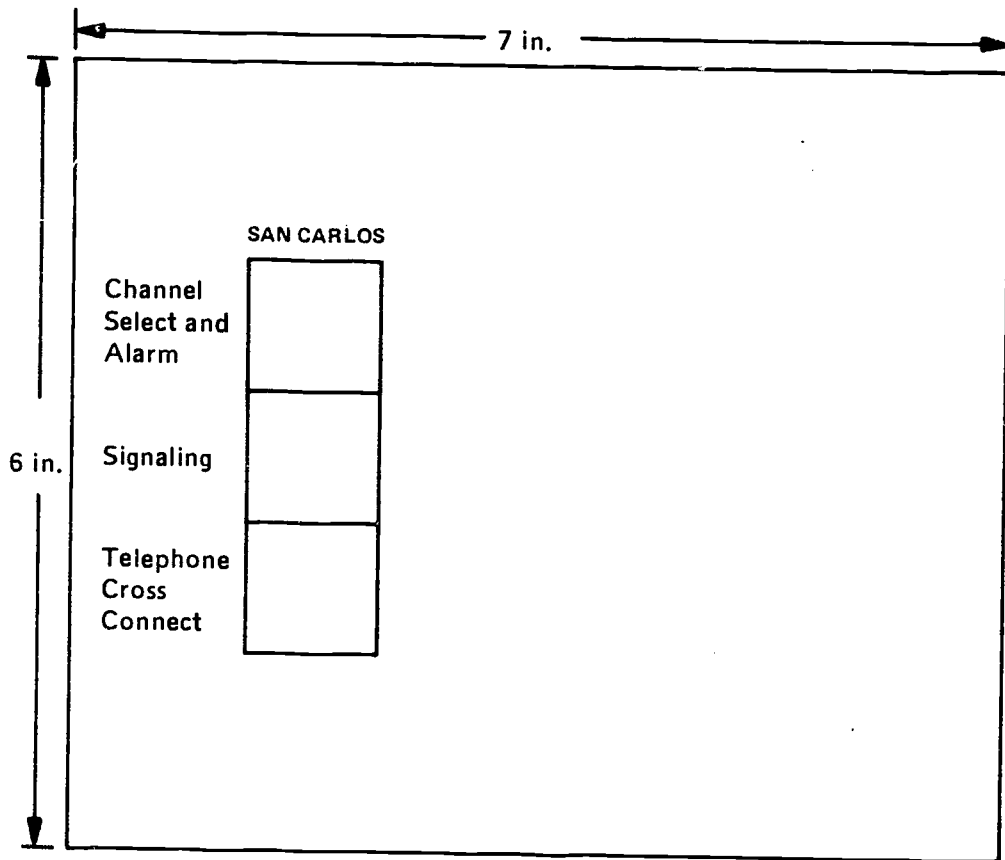

Figure D.14. AdVC Panel Layout at Bylas.

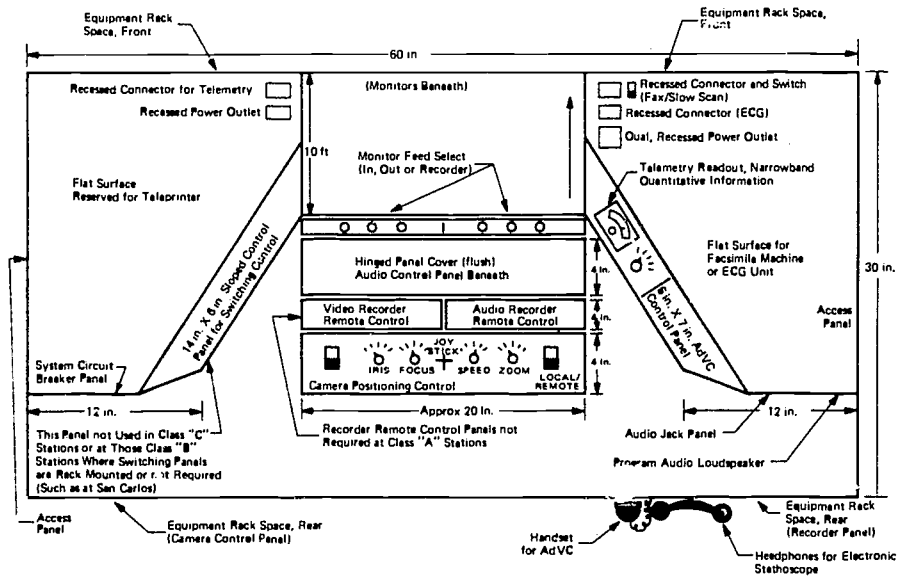
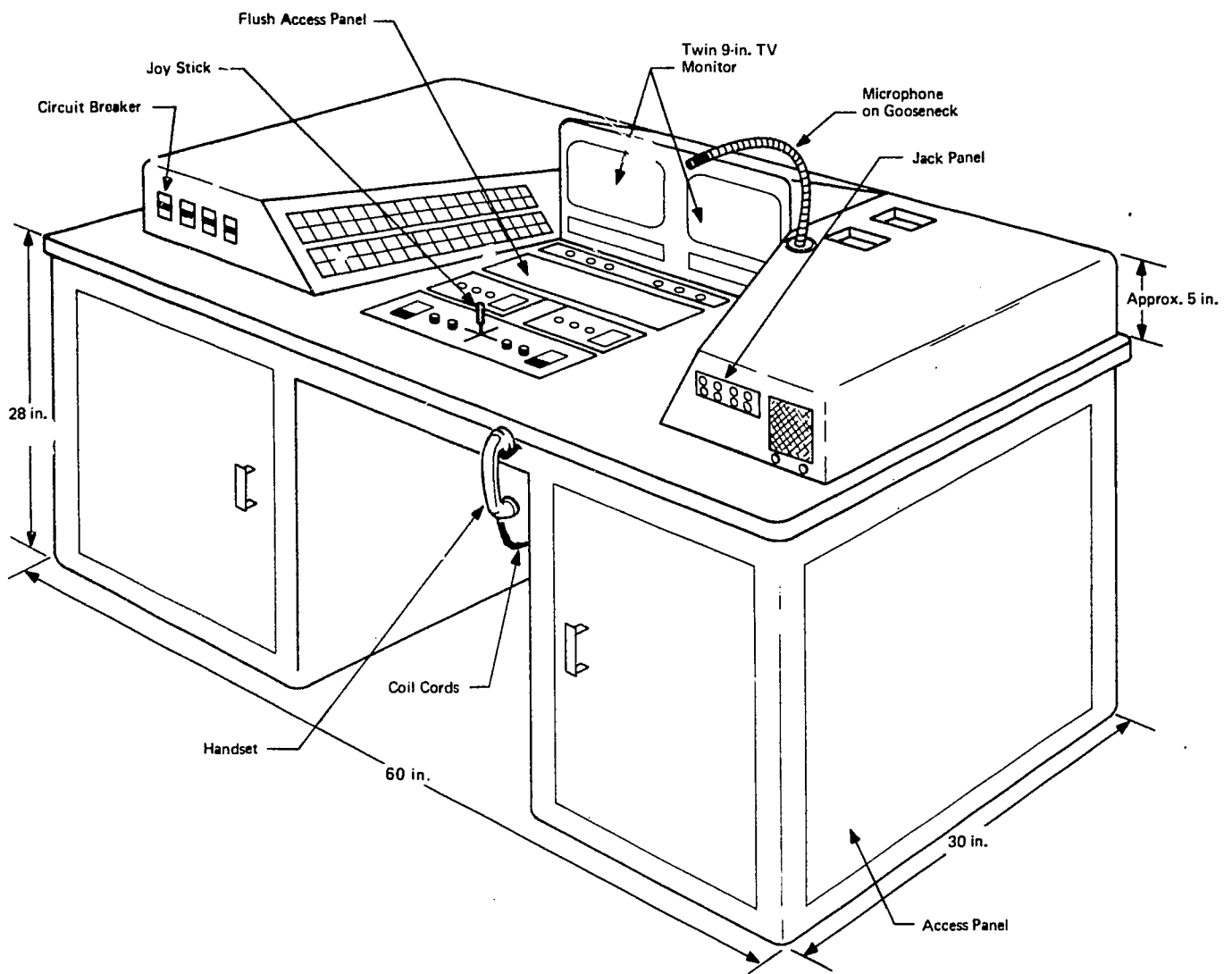

Figure D.15. Typical Control Console.

D-21

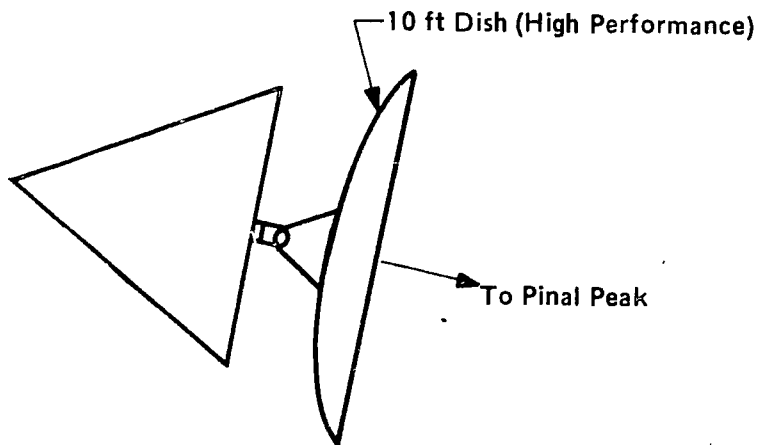
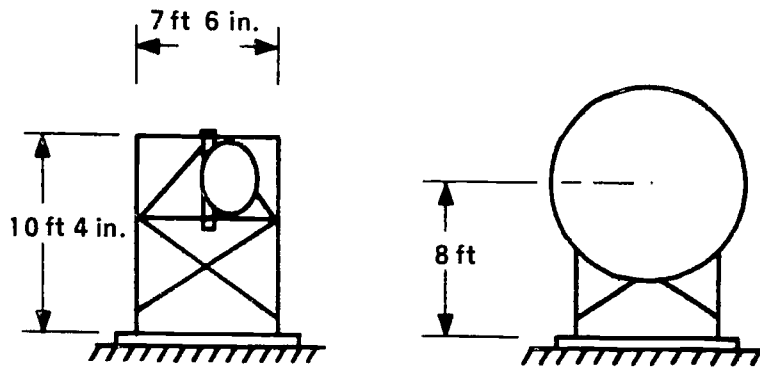
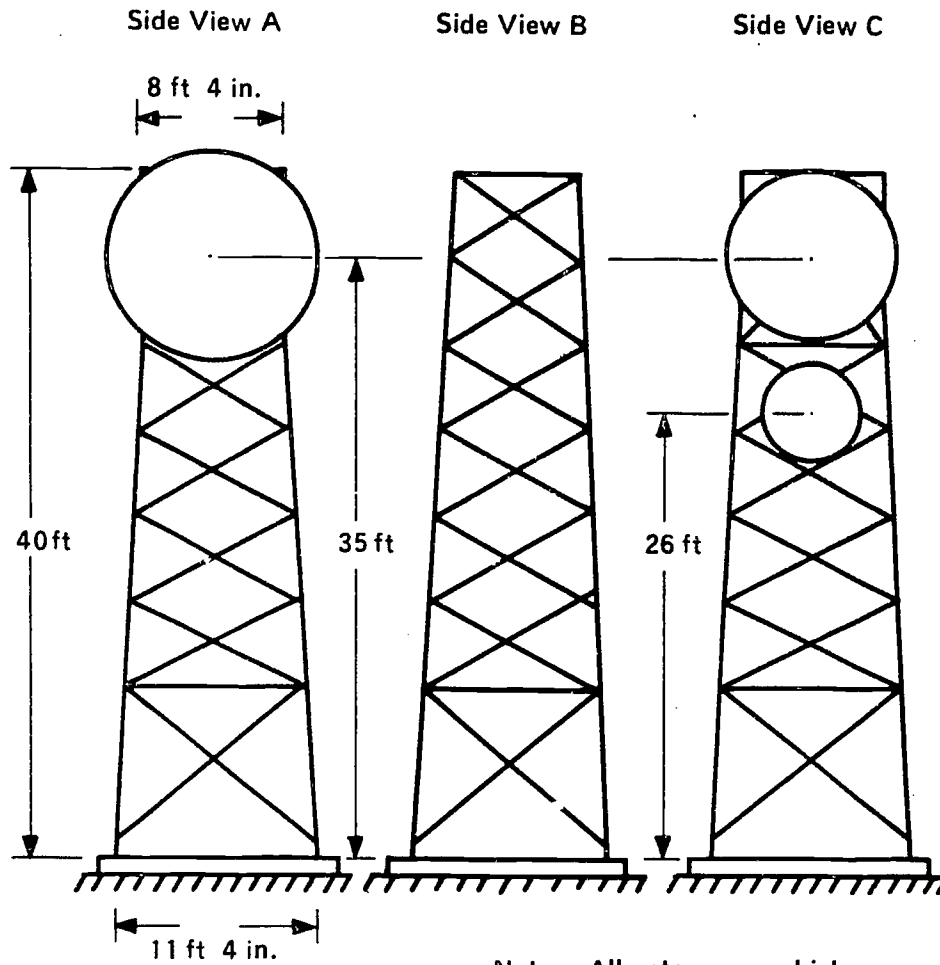

Figure D.16. Support Structure and Antenna Arrangement at Phoenix.



Note: All antennas are high performance except for San Carlos (12 GHz) link.

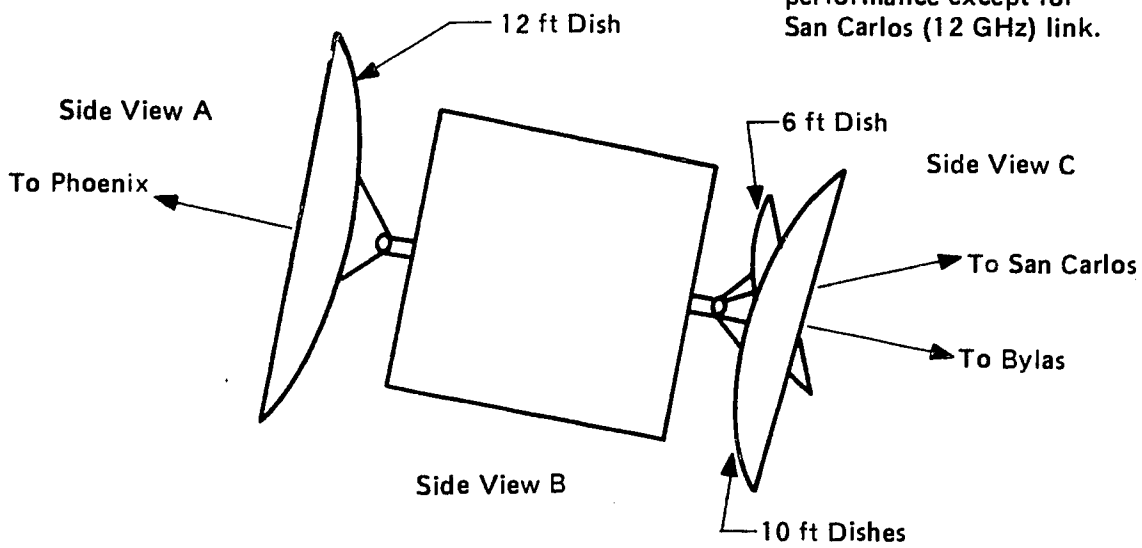

Figure D.17. New Tower and Antenna Arrangement at Pinal Peak.

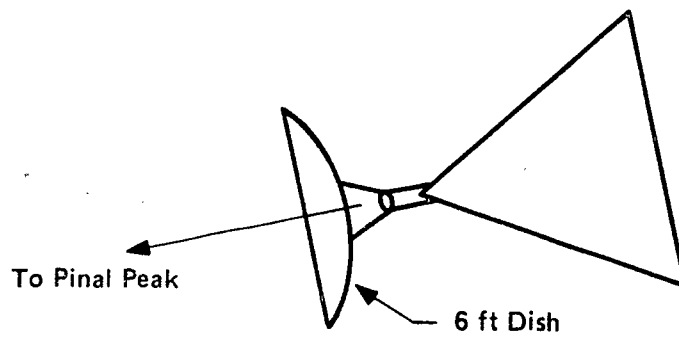
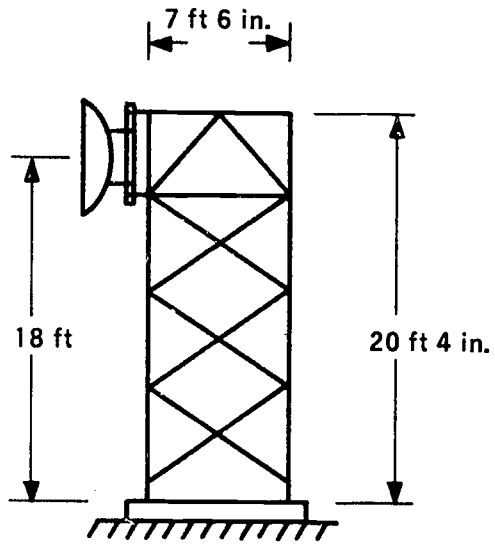

Figure D.18. New Tower and Antenna Arrangement at San Carlos.

D-24

148

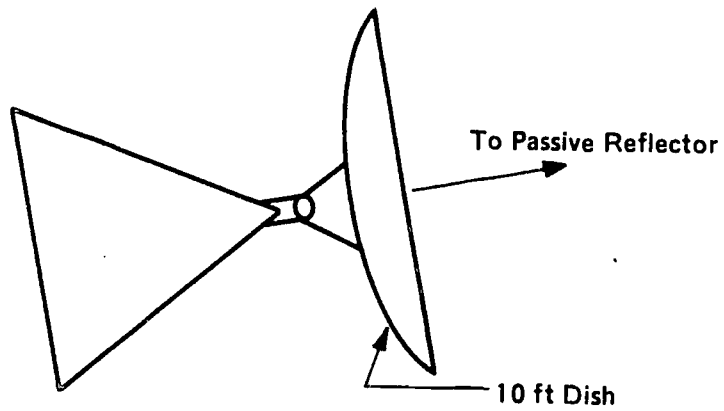
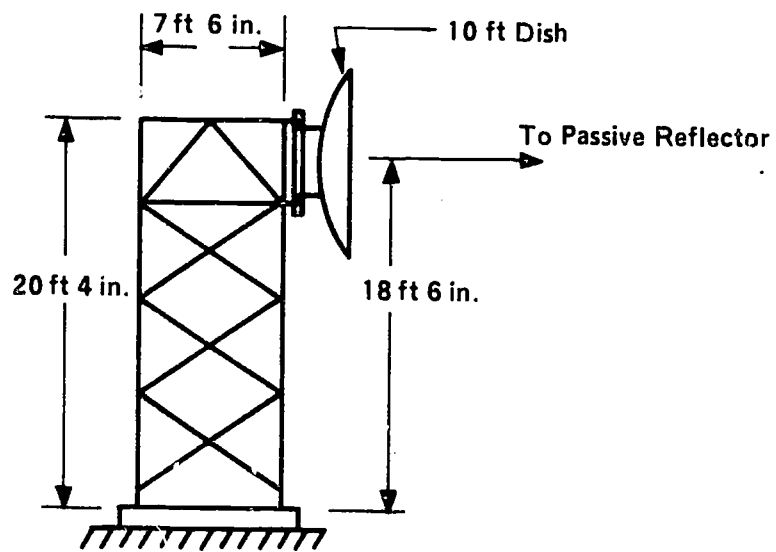

Figure D.19. New Tower and Antenna Arrangement at Bylas.

D-25

<u>Item</u>	<u>Description Specific Mfgr. or Equivalent</u>
Audiometer	Maico MA16
Blood Pressure Unit	Baumanometer, Mercury 300 mm
Cameras	Polaroid ED10 (Microscope) CU5 (Close-up)
Cauterizer	Hyfrecator, Birtcher
Centrifuge	Microhematocrit Centrifuge, Adams; Clinical Centrifuge – International Model CL
Electrocardiograph	Hewlett-Packard 1500A
Electronic Stethoscope	Hewlett-Packard 1506B
Eye Chart	Snellen Wall Chart
Incubator, Bacterial	Imperial J1600
Microscope	American Optical
Ophthalmoscope-Otoscope	Welch Allyn
Oxygen	
Refrigerator	
Scales; adult, baby	Detecto
Skin Fold Caliper	
Refractometer	American Optical
Spirometer	Collins P700 with Potentiometer P372A; Collins Timed Vitalometer P700
Tonometer (Scheoctz)	R. O. Gulden Company

Figure D.20. Medical Equipment List — Major Items
(quantity of one unless specified otherwise).

<u>Item</u>	<u>Description Specific Mfg. or Equivalent</u>
Reflex Hammer	
Stethoscope	Littman 3M
Tape Measure	Steel or Linen
Head Lamp	
Laryngeal Mirror	
Tuning Fork 128 cps	

Basic Furnishing

<u>Item</u>	<u>Description Specific Mfg. or Equivalent</u>
Examination Table	
Incandescent Floor Lamp	Luxo Style
Desks, Chairs, etc.	

Laboratory

<u>Item</u>	<u>Description Specific Mfg. or Equivalent</u>
Unopette System	Bector Dickenson Company
Bilelabstix	Amex #2814

Figure D.20. (continued)

Arizona TeleMedicine Network

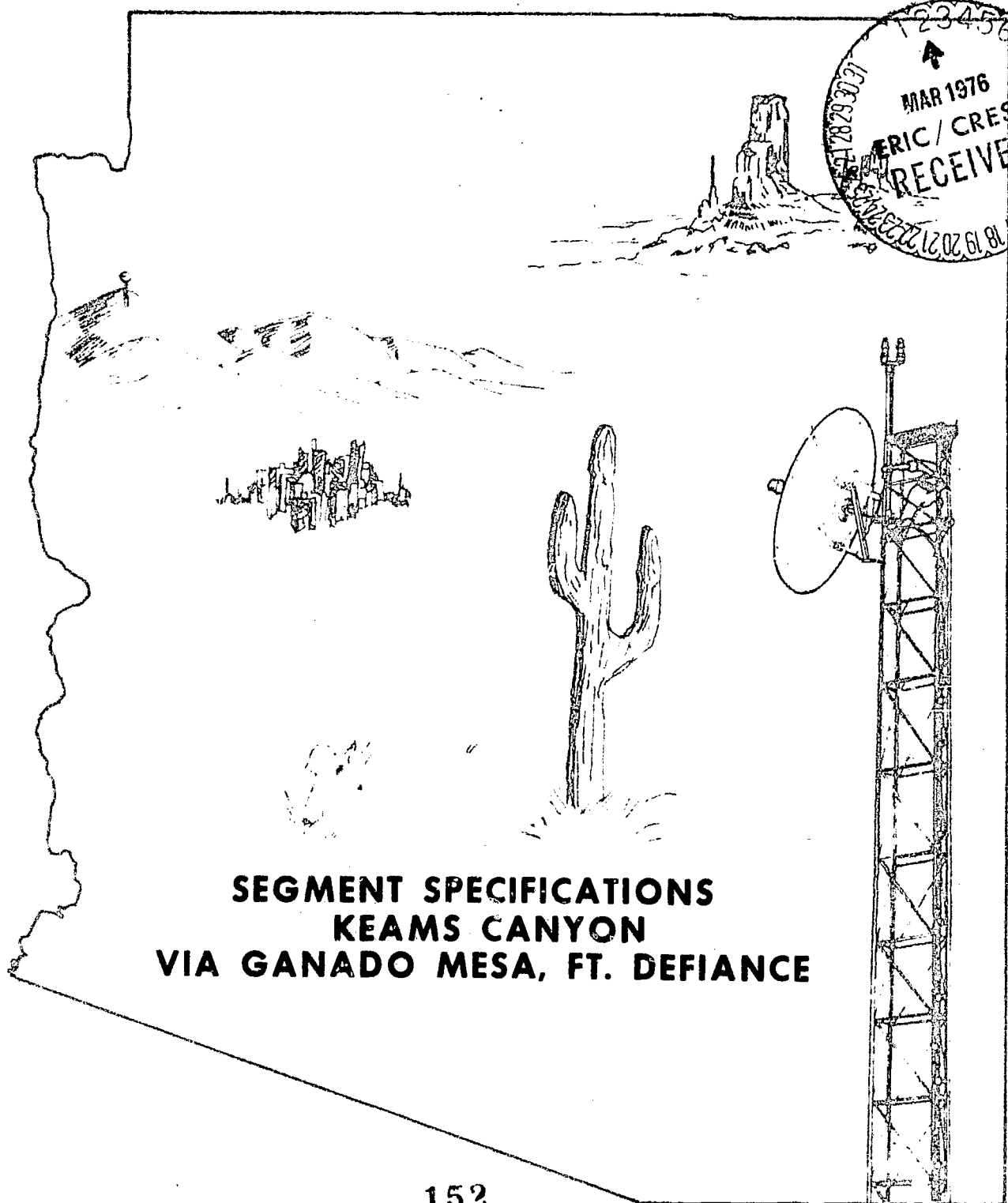

**SEGMENT SPECIFICATIONS
KEAMS CANYON
VIA GANADO MESA, FT. DEFIANCE**

152

UNIVERSITY OF ARIZONA, COLLEGE OF MEDICINE

RC009027



THE ARIZONA TELEMEDICINE NETWORK

SEGMENT SPECIFICATIONS

Keams Canyon, via Ganado Mesa, Fort Defiance

Prepared for:

**The University of Arizona College of Medicine
Department of Family and Community Medicine
Tucson, Arizona 85724**

Prepared by:

**The Biomedical and Special Systems Group
Telecommunications Activity
Atlantic Research Corporation
Alexandria, Virginia 22314**

May 30, 1973

TABLE OF CONTENTS

	Page
1.0 SCOPE	1-1
2.0 SYSTEM DESIGN	2-1
2.1 Communications Channels	2-1
2.2 Selection of Microwave Routes	2-2
2.3 Control of Signal Switching	2-3
2.3.1 Keams Canyon Relay (Class "R1" Station)	2-3
2.3.2 Ganado Mesa Relay (Class "R1" Station)	2-4
3.0 APPLICABLE DOCUMENTS	3-1
4.0 SPARE EQUIPMENT AND MATERIALS REQUIREMENT	4-1
APPENDIX A – Path Profiles	
APPENDIX B – Site Maps	
APPENDIX C – Site Photographs	
APPENDIX D – Drawings	

1.0 SCOPE

This document defines one segment of the Arizona TeleMedicine Network as referred to in the System Procurement Specifications. The basic requirements shall be as given by the general document as amended by unique requirements for this segment given herein.

The segment defined here is a communication link between Keams Canyon Relay and Ganado Mesa Relay via a relay at Steamboat Junction with Administrative Voice Channels extended to Keams Canyon Hospital and Ft. Defiance Hospital. Figure 1.1 illustrates this segment.

This document describes the unique requirements necessary to implement the segment and details all allowances to be made to facilitate anticipated expansions to the network.

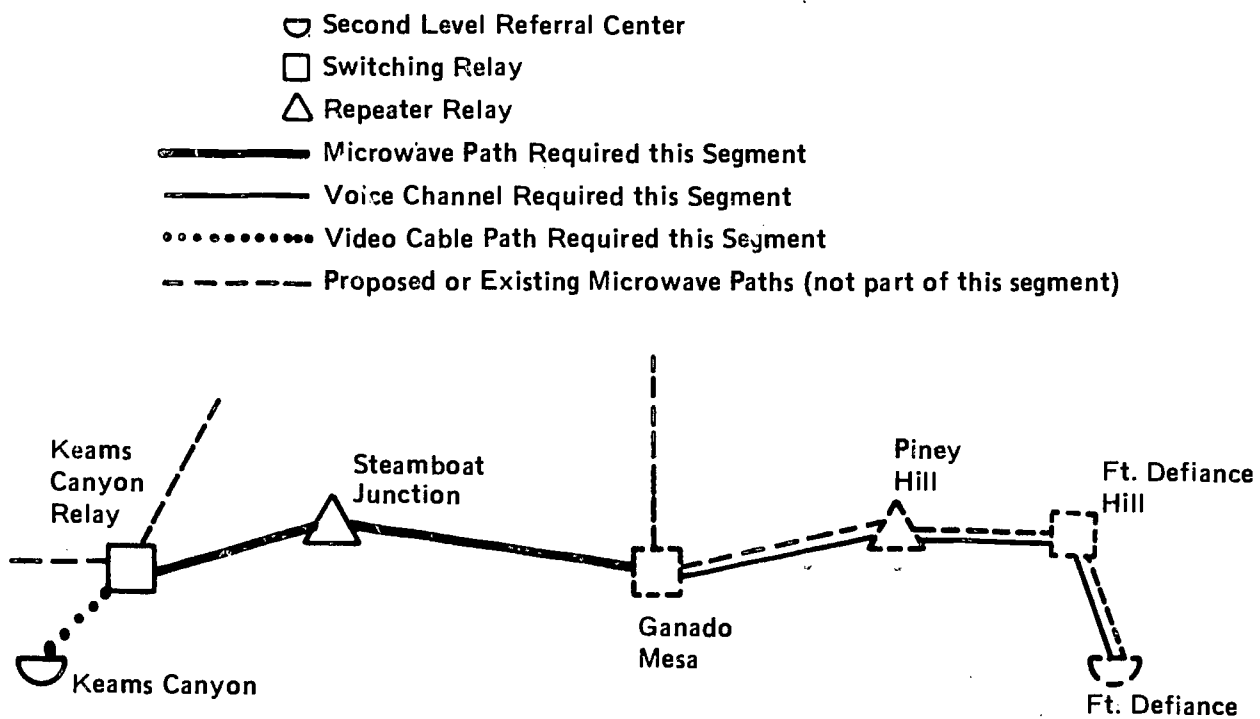

Figure 1.1. Keams Canyon, via Ganado Mesa, Fort Defiance Segment.

2.0 SYSTEM DESIGN

2.1 Communications Channels

The full duplex microwave segment shall be channelized to carry the following services.

- Full color television (525 line/30 frame with 5.5 MHz bandpass) – one channel
- Program audio (15 kHz bandpass) – one channel
- Order wire (with selective signaling) – one channel
- “Voice” slots (FDM, 4 kHz spacing) – up to 12 channels
- Alarm circuits – see channelization plan

A further breakdown of the use of the “voice” slots is included in the suggested spectrum utilization plans for each link within the segment (see Appendix D.1).

The designated voice slots shown are to be used for the following services:

- Camera positioning control (tilt, pan, focus, zoom, iris, mono/color – six channels (dc control) per voice slot
- Teleprinter/keyboard (300 baud – six channels per voice slot, one channel per site
- Telemetry (IRIG Standard) dc to 500 Hz – one channel, single voice slot per site
- Slow-scan television (approximately one frame per two-minute interval) – one channel, single voice slot
- Switching control relay sites, remote – touch tones, share administrative voice slot
- Administrative Voice Channel(s) – see channelization plan

All locations in the segment shall be provided with modems, FSK transmitter/receivers, FM telemetry devices and such required interface equipment as may be required to facilitate these services at each terminal site.

2.2 Selection of Microwave Routes

The suggested sites for this segment are described as follows. Path profiles, site maps, photographs and drawings are provided in Appendices A, B, C and D, respectively.

Keams Canyon Relay

The Contractor can assume that suitable tower, power and equipment space are already available at the site shown on Figure B.1 and in Figure C.1. A new 6-foot antenna shall be installed at the 80-foot level of the existing 150-foot guyed tower. This antenna shall be oriented at a bearing of approximately 95 degrees towards the relay site at Steamboat Junction. Radio equipment shall be installed within the existing shelter and waveguide shall be attached to the existing tower. All communication channels shall be wired into the existing matrices according to the channelization plan and switching plans. A new Administrative Voice Channel shall be connected from the Keams Canyon Hospital to the relay site using the 36 to 40 kHz voice slot.

Steamboat Canyon

The Steamboat Canyon relay site as shown on Figure B.2 is an undeveloped site which will require both primary and secondary power supplies. A new tower and antennas are required as shown in Figure D.4. Figure D.5 is a generalized site plan for the new relay which may have to be adjusted for local terrain. No switching shall take place at this relay site.

The land to be utilized for this site must be accurately identified and proper land use agreements obtained from the appropriate authorities.

Ganado Mesa

The Contractor can assume that suitable tower, power and equipment space are available at the site as shown on Figure B.2. Figure C.2 shows existing telephone company facilities at Ganado Mesa.

A new 6-foot antenna shall be installed on the existing tower at the 30-foot level at a bearing of approximately 274 degrees towards the Steamboat Canyon Relay.

Radio equipment shall be installed within the existing shelter and waveguide shall be attached to the existing tower.

The Contractor shall provide and install appropriate switch matrices for switching the communications channels in accordance with the switching plans given in this document.

Channel equipment shall be installed to connect the AdVC line for Ft. Defiance in the 48 to 52 kHz slot.

Ft. Defiance Hill and Ft. Defiance Hospital

At these two locations the channel equipment shall be installed to complete the AdVC to Ft. Defiance from Keams Canyon. The channel shall be the 48 to 52 kHz slot.

2.3 Control of Signal Switching

In this segment of the Arizona TeleMedicine Network, the following control and switching relationships shall prevail:

Switching Relay	Control Station
Keams Canyon Relay	Keams Canyon Hospital
Ganado Mesa Relay	Ft. Defiance Hospital

Refer to the System Procurement Specifications document for a general discussion of switching concepts.

2.3.1 Keams Canyon Relay (Class "R1" Station)

At this site three transmit/receive (T/R) pairs are already switched by the matrices previously installed. The following T/R pair is to be wired to the existing matrices.

Ganado Mesa: This T/R pair links the switch point at Keams Canyon Relay to the switch point at Ganado Mesa.

The Keams Canyon Hospital controls the existing matrices. The new switches required to transmit the "touch tones" for the add T/R pair are to be installed at the control panel as shown in Figure D.3.

The AdVC panel is to be wired for the new link to Ft. Defiance as shown in Figure D.2.

2.3.2 Ganado Mesa Relay (Class "R1" Station)

At this site three transmit/receive (T/R) pairs are brought together for switching. They are as follows:

Ft. Defiance Hill: This T/R pair links the Ganado Mesa switch point to the Ft. Defiance Hill switch point.

Chinle: This T/R pair links the Ganado Mesa switch point to the Chinle switch point.

Keams Canyon: This T/R pair links the Ganado Mesa switch point to the Keams Canyon switch point.

Ft. Defiance Hospital is in remote command of the various switch configurations at Ganado Mesa. Ft. Defiance shall have installed, as applicable, a group of illuminated push buttons to control the stations switching tones. These tones will be generated by oscillator modules that produce the dual frequency notes commonly called "touch tones." These tones will be transmitted to the Ganado Mesa switch point via the Keams Canyon AdVC.

In general each transmit and receive circuit of the duplex link is switched separately. The various switch configurations possible are shown in Figure D.6.

3.0

APPLICABLE DOCUMENTS

The Arizona TeleMedicine Network,
System Procurement Specifications, May 1973

4.0

SPARE EQUIPMENT AND MATERIALS REQUIREMENT

The Contract shall, as part of this construction contract, supply the following list of spare parts, components, panels, equipment and material. Delivery shall be to the site as stipulated by the Project Director. Delivery shall be effected prior to final acceptance.

- 1 set Modules for multiplex equipment (12 channels)
- 1 set Common equipment modules, panels and circuit boards (not channel dependent) for microwave radio equipment for both 6 GHz and 12 GHz units
- 4 each Video switcher modules
- 4 each Audio frequency switcher modules
- 4 boxes Fuses of all types

APPENDIX A

PATH PROFILE

Note: When towers are not specified on the Vertical Earth Profiles, only minimum tower heights governed by antenna size, will be required.

Note: Corrections for earth curvature and Fresnel zone radius have been included on each profile:

Δ 0.3 first Fresnel zone radius

Δ earth curvature for $k = 2/3$

A-1

163

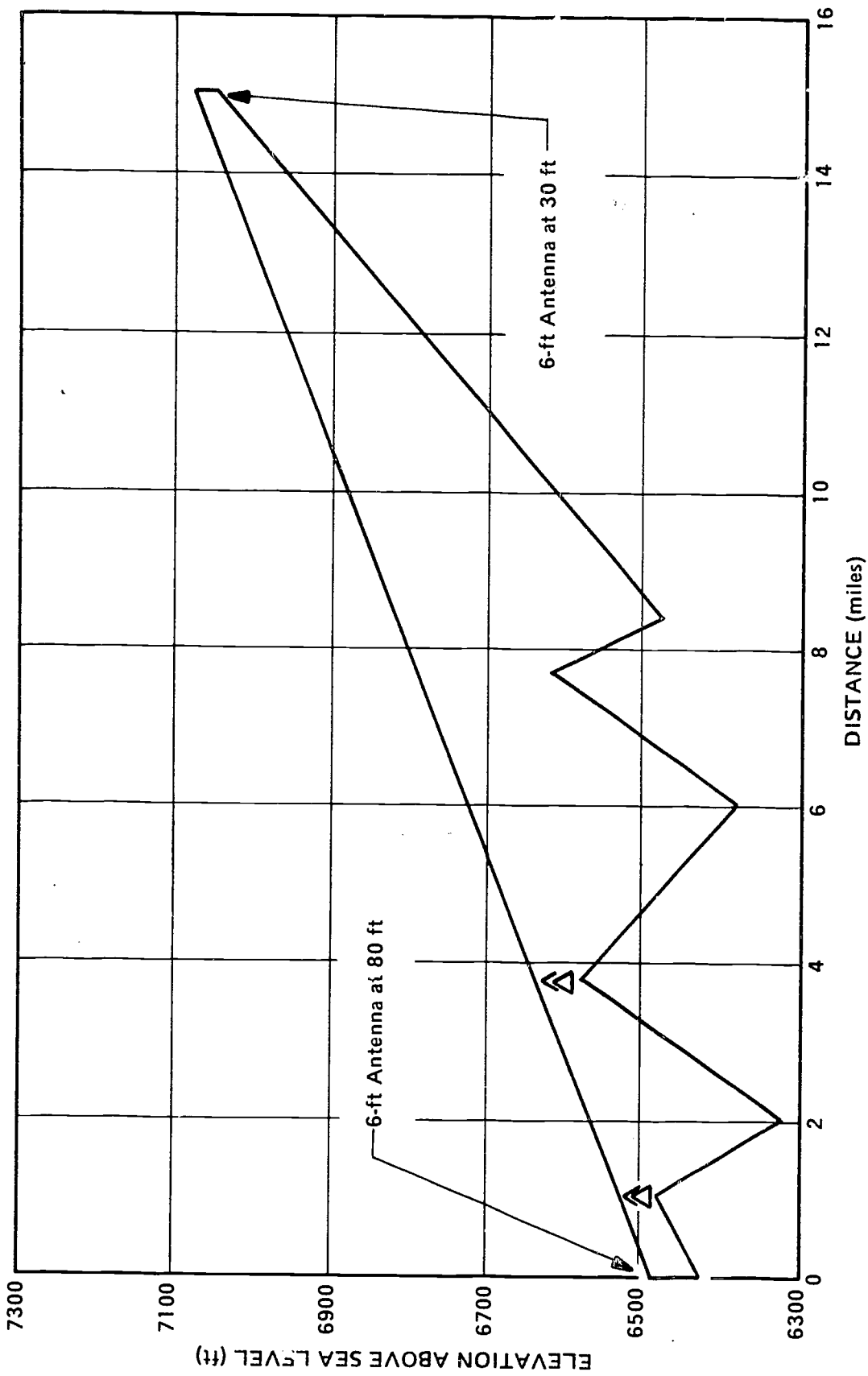

Figure A.1. Microwave Path Profile, Keams Canyon Relay to Steamboat Canyon Relay.

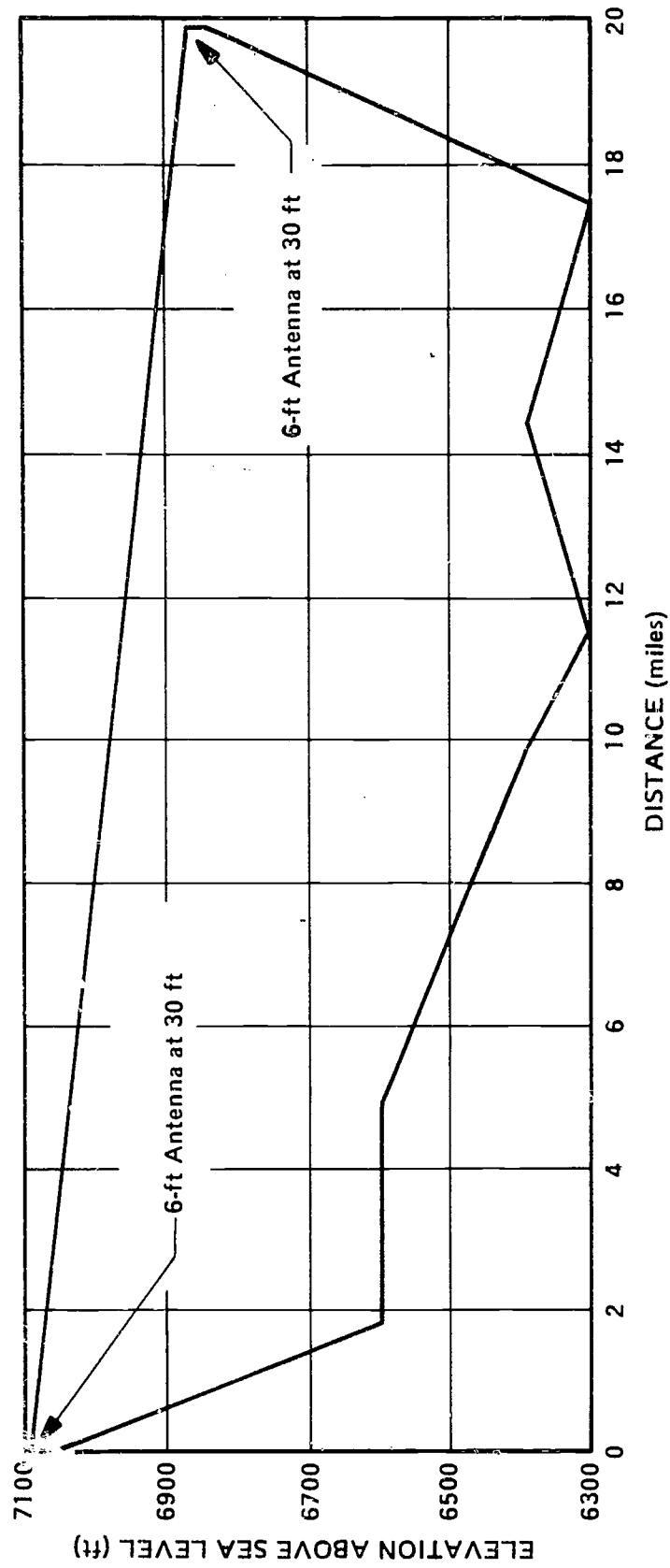

Figure A.2. Microwave Path Profile, Steamboat Canyon Relay to Ganado Mesa Relay.

APPENDIX B

SITE MAPS

B-1

166

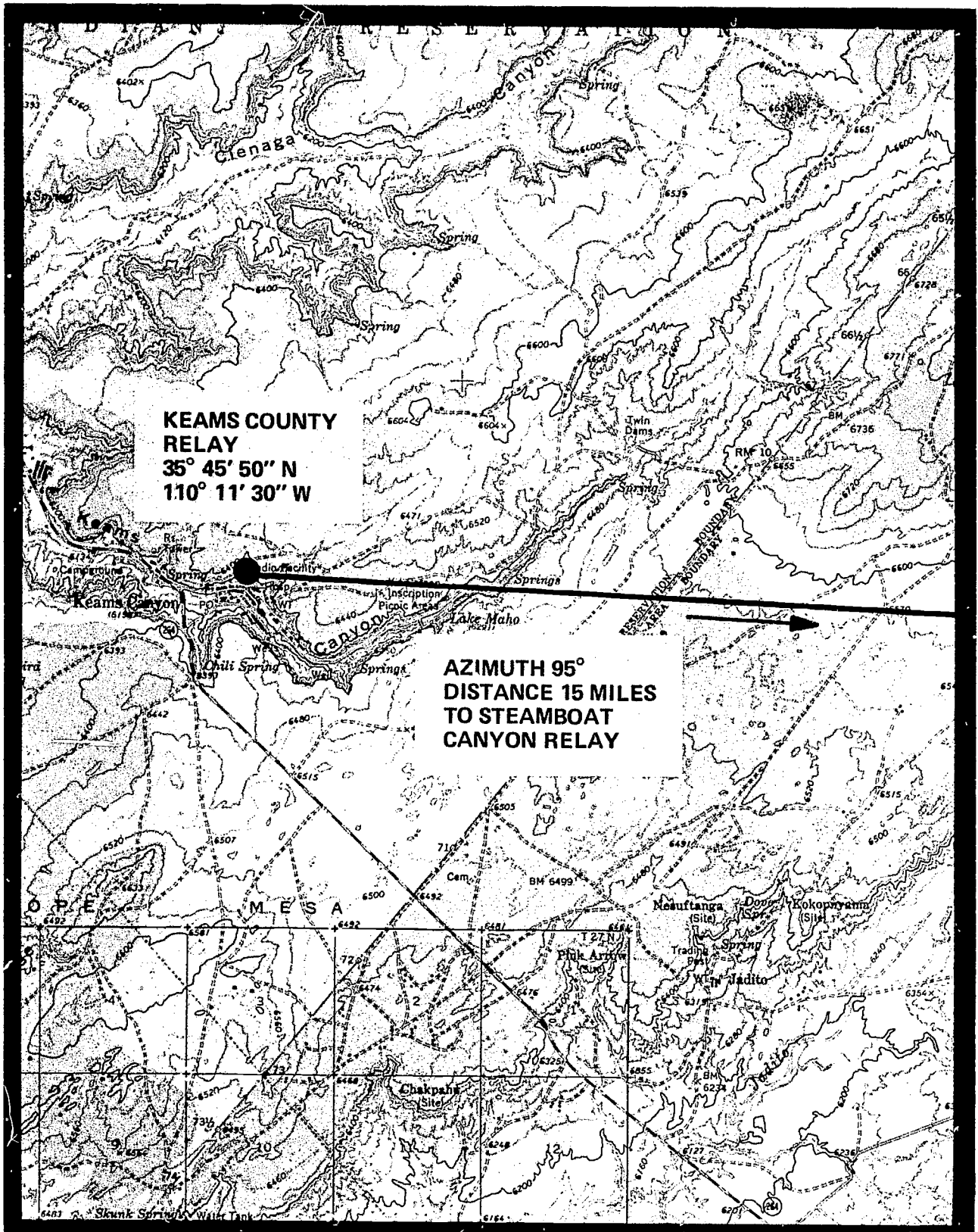

Figure B.1. Site Map Showing Keams Canyon Relay.

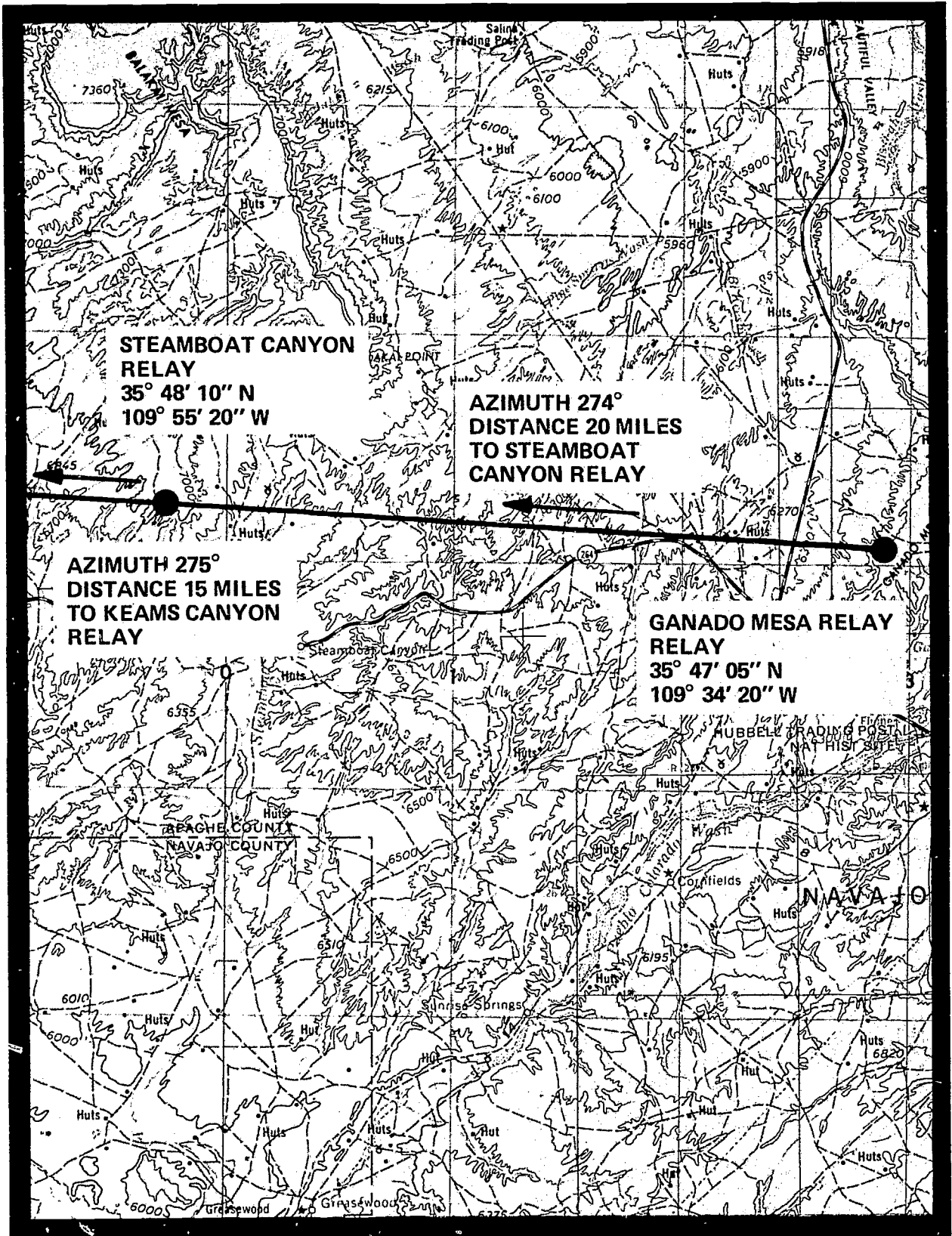

Figure B.2. Site Map Showing Steamboat Canyon Relay and Ganado Mesa Relay.

APPENDIX C

SITE PHOTOGRAPHS

169
c-1

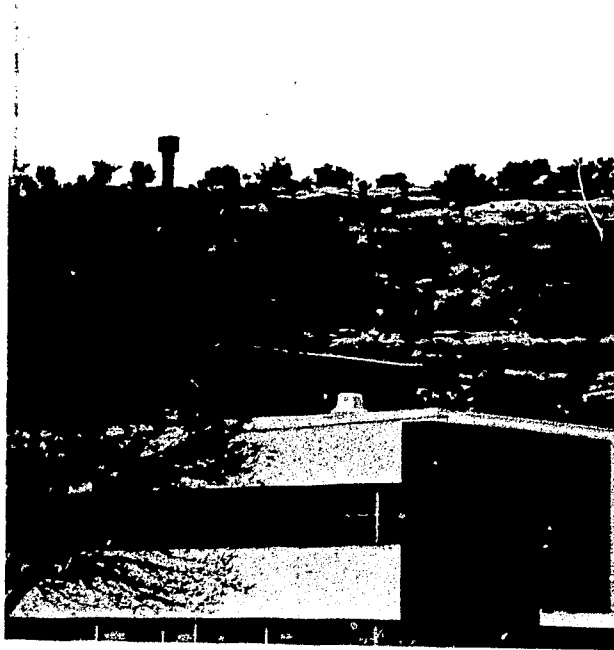

Figure C.1. View Toward Keams Canyon Relay Site on Cliff Behind Keams Canyon Hospital.

(no photograph available)

Figure C.2. Steamboat Canyon Relay Site.

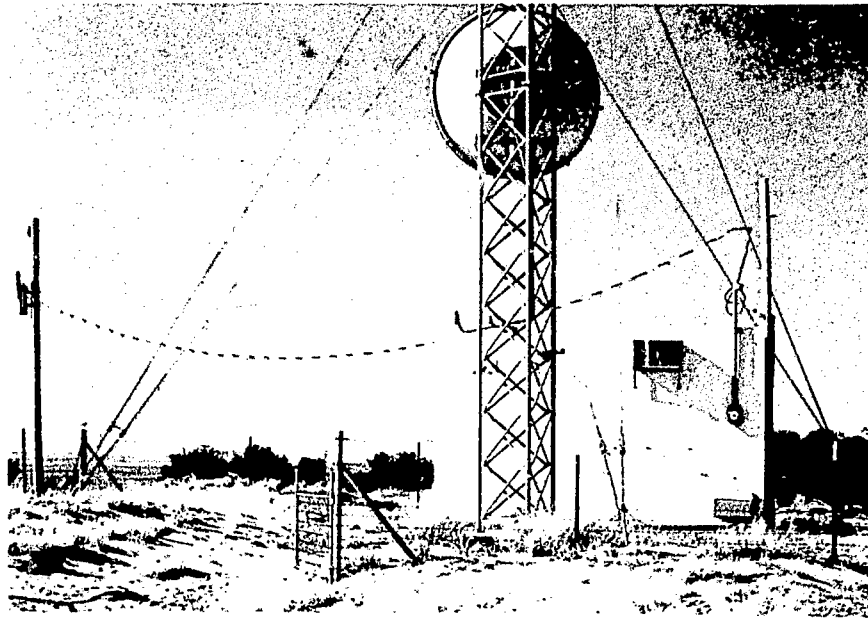

Figure C.3. Existing Telephone Company Facilities at Ganado Mesa.

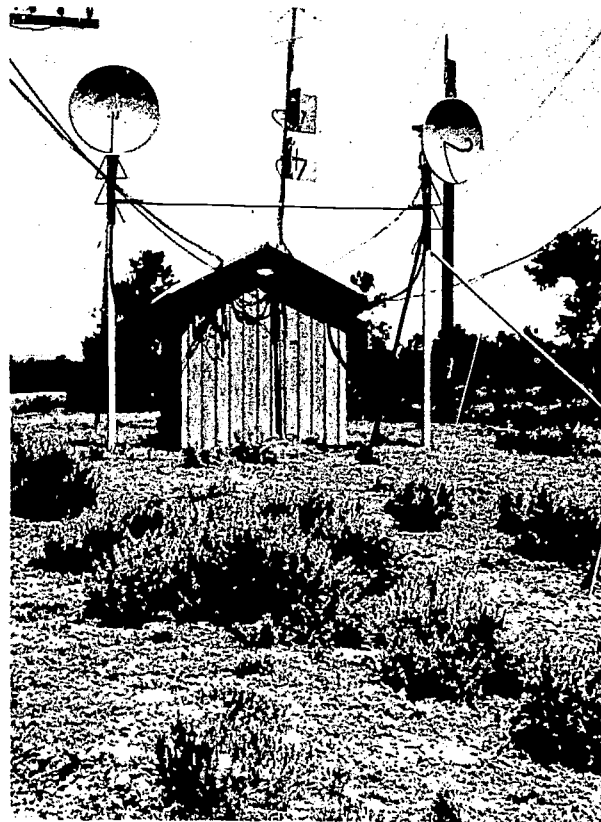

Figure C.4. Existing Telephone Company Facilities at Fort Defiance Hill.

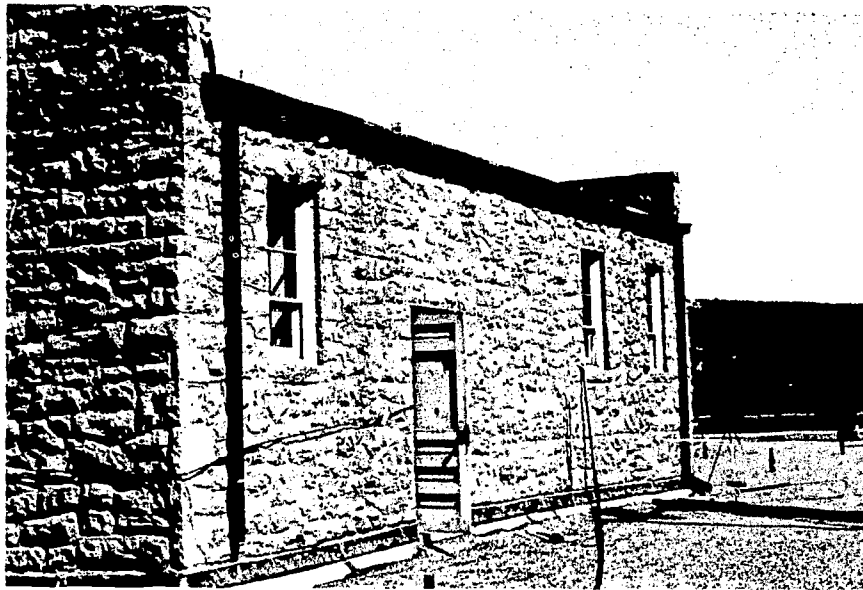

Figure C.5. Fort Defiance Hospital Penthouse.

APPENDIX D

DRAWINGS

D-1

173

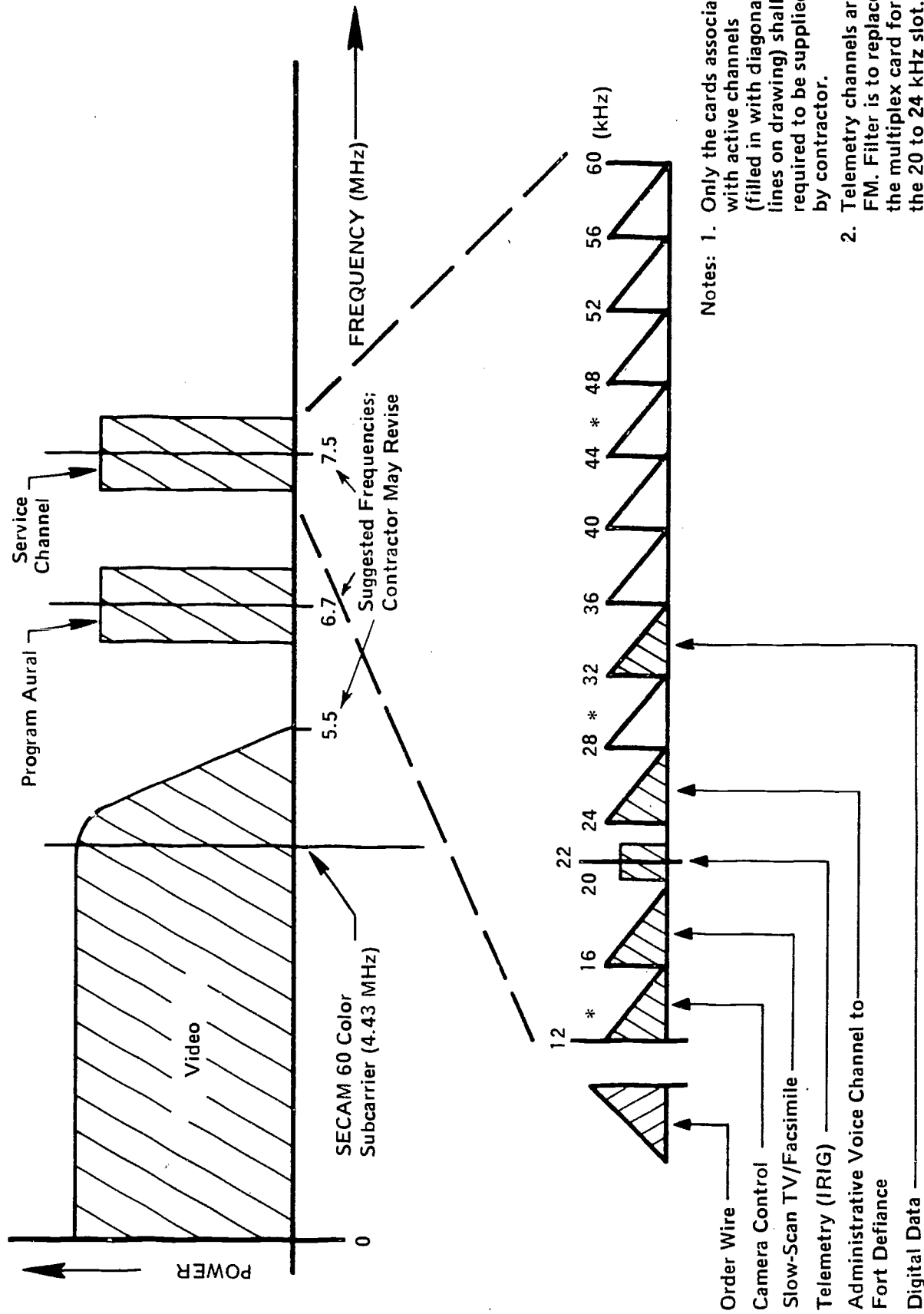

Figure D.1. Channelization Plan, from Keams Canyon Relay to Ganado Mesa Relay.

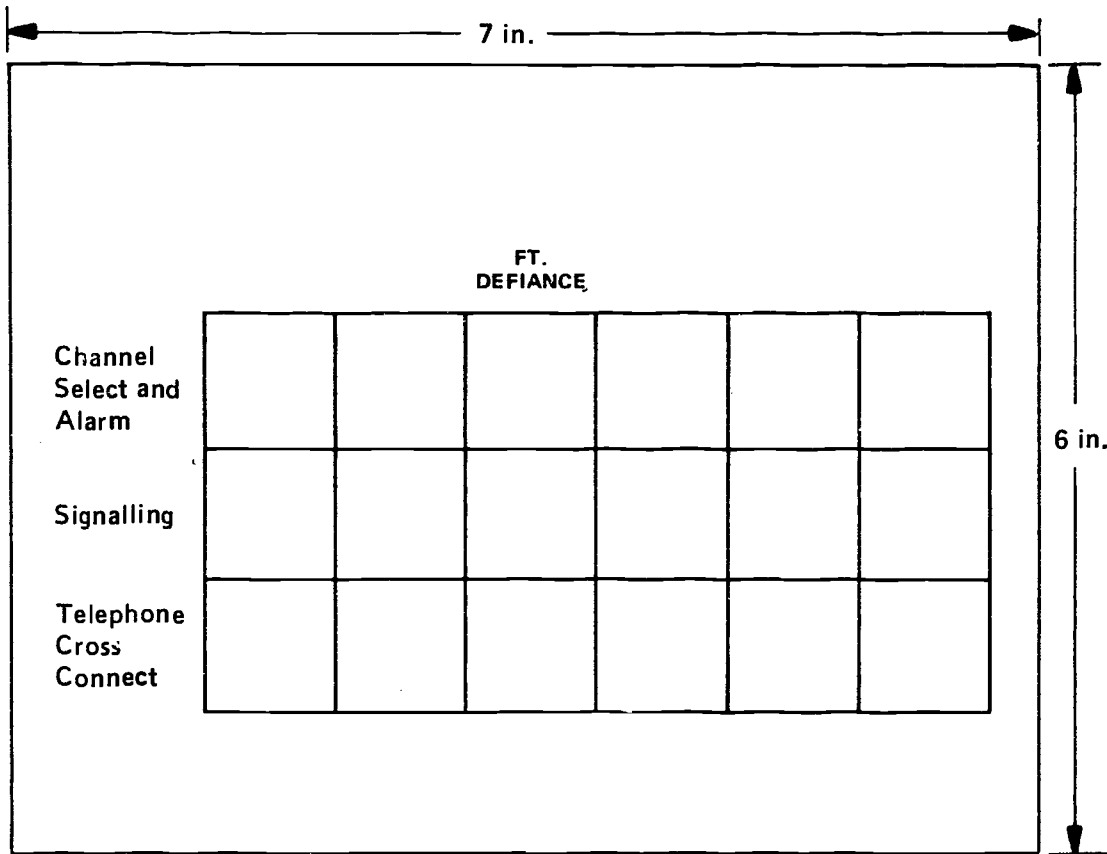

Figure D.2. AdVC Panel at Keams Canyon.

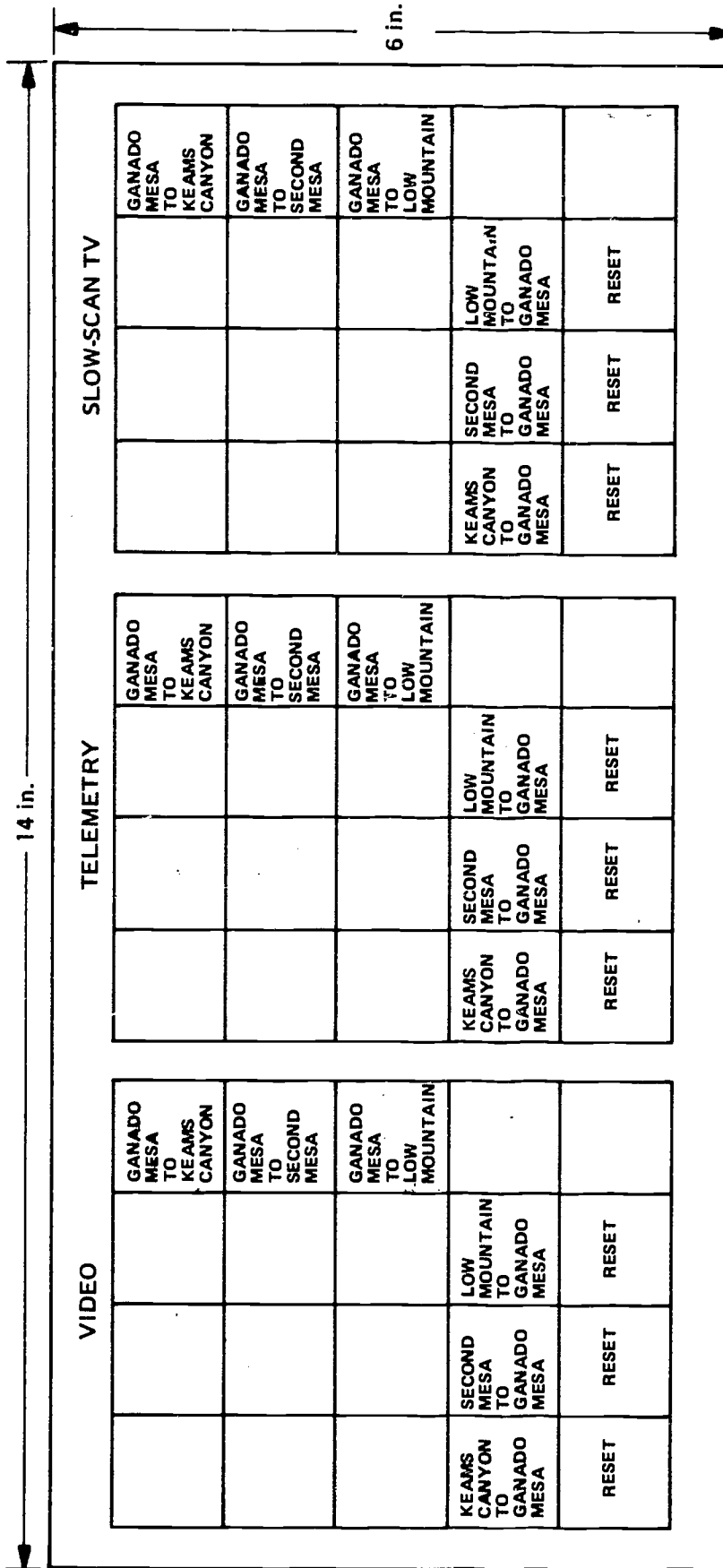

Figure D.3. Switching Control Panel Layout, Keams Canyon Hospital.

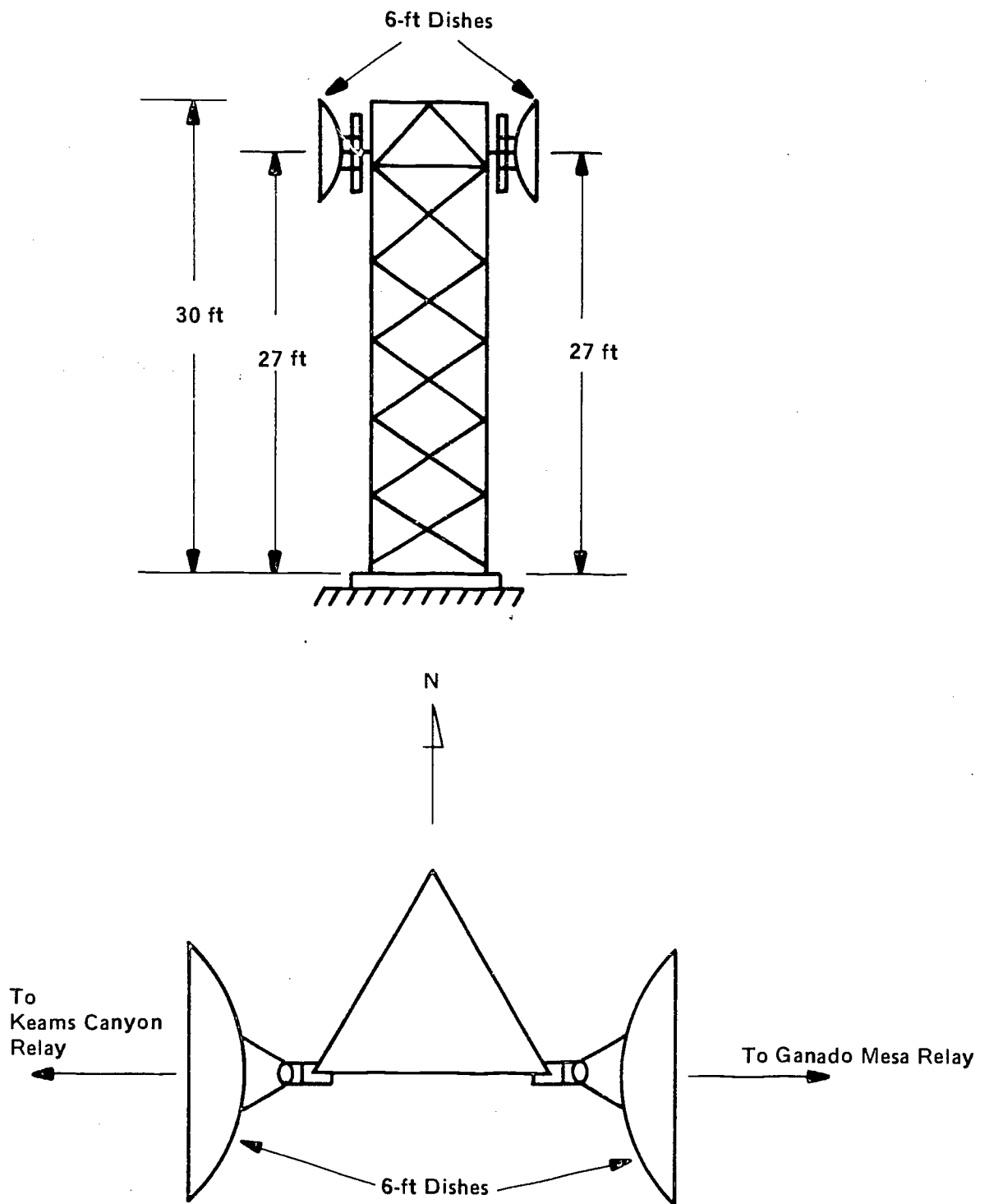

Figure D.4. New Antenna and Tower Arrangement at Steamboat Canyon.

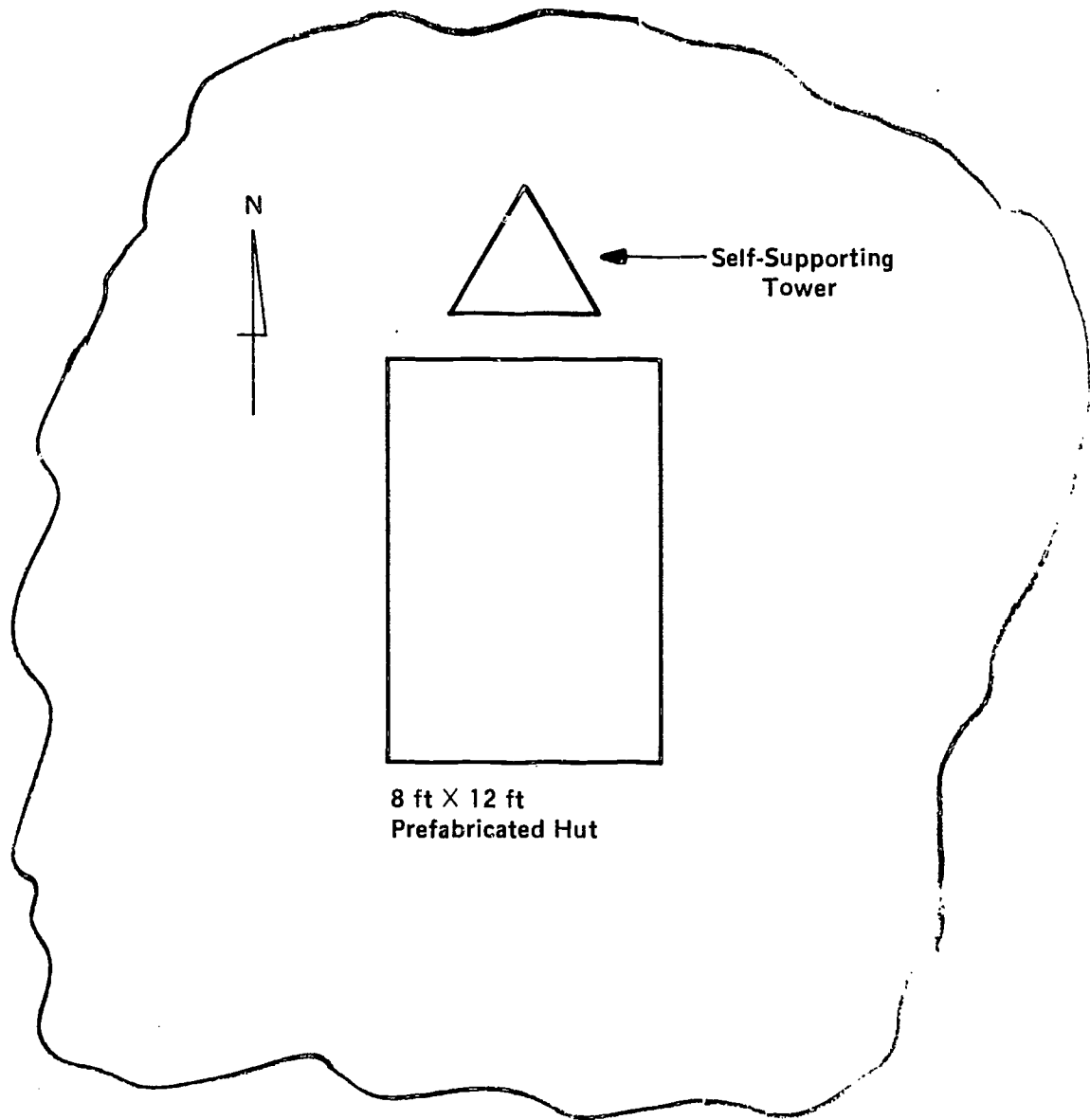

Figure D.5. Generalized Site Plan for Steamboat Canyon Relay.

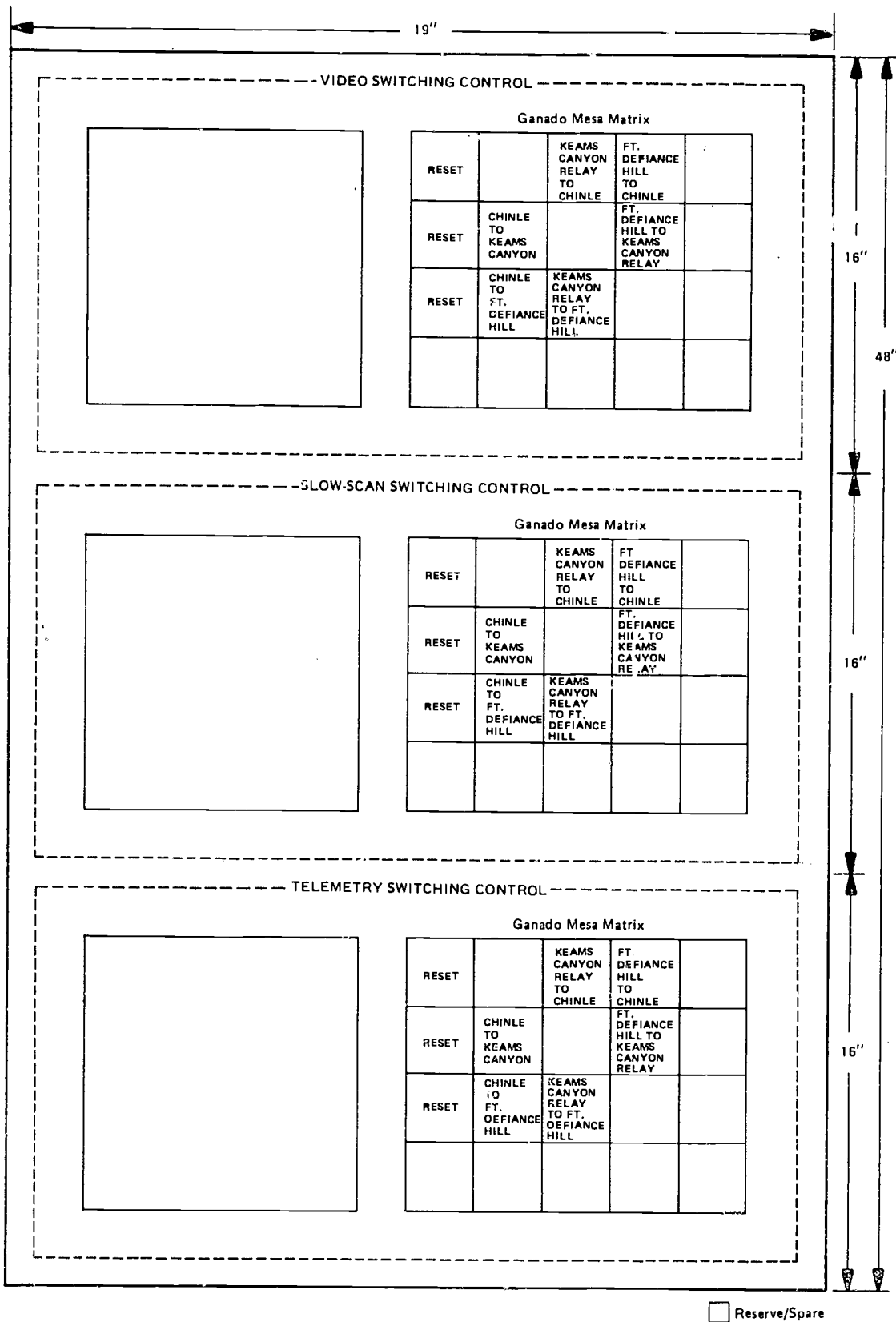

Figure D.6. Switching Control Panel Layout at Fort Defiance Hospital.

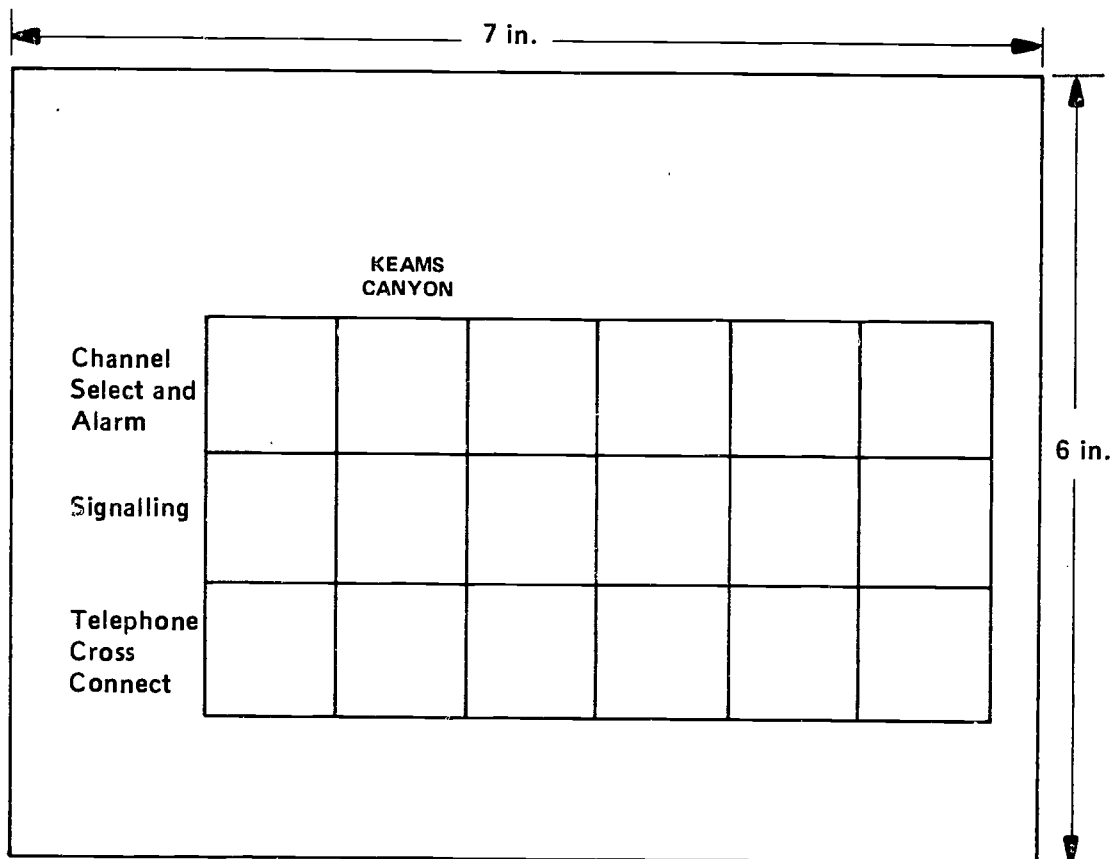
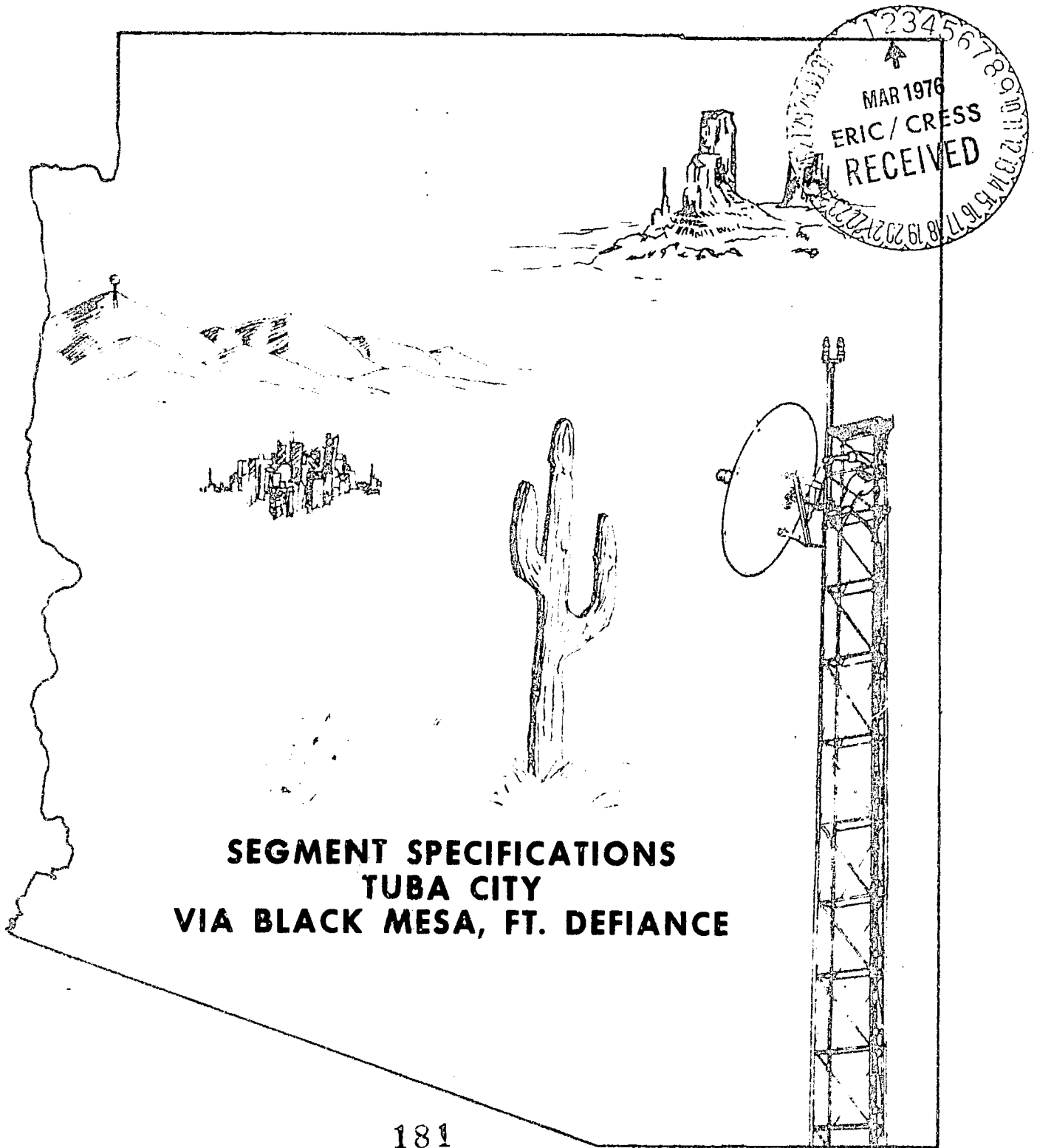

Figure D.7. AdVC Panel at Fort Defiance Hospital.

Arizona TeleMedicine Network



RC009027

UNIVERSITY OF ARIZONA, COLLEGE OF MEDICINE

THE ARIZONA TELEMEDICINE NETWORK

SEGMENT SPECIFICATIONS

Tuba City, via Black Mesa, Ft. Defiance

Prepared for:

**The University of Arizona College of Medicine
Department of Family and Community Medicine
Tucson, Arizona 85724**

Prepared by:

**The Biomedical and Special Systems Group
Telecommunications Activity
Atlantic Research Corporation
Alexandria, Virginia 22314**

May 30, 1973

TABLE OF CONTENTS

	Page
1.0 SCOPE	1-1
2.0 SYSTEM DESIGN	2-1
2.1 Communications Channels	2-1
2.2 Selection of Microwave Routes	2-2
2.3 Control of Signal Switching	2-2
2.3.1 Shonto Switch Point (Class "a" Station)	2-3
2.3.2 Black Mesa Switch Point (Class "R1" Station)	2-4
2.3.3 Yale Point Switch Point (Class "R1" Station)	2-4
2.3.4 Control Panel at Tuba City	2-5
2.3.5 Administrative Voice Channel	2-5
3.0 APPLICABLE DOCUMENTS	3-1
4.0 SPARE EQUIPMENT AND MATERIALS REQUIREMENT	4-1
APPENDIX A – Path Profiles	
APPENDIX B – Site Maps	
APPENDIX C – Site Photographs	
APPENDIX D – Drawings	

1.0

SCOPE

This document defines one segment of the Arizona TeleMedicine Network as referred to in the System Procurement Specifications. The basic requirements shall be as given by the general document as amended by unique requirements for this segment given herein.

The segment defined here is a communication link between switching relays at Shonto, Black Mesa, and Yale Point. Figure 1.1 illustrates this segment.

This document describes all equipment required to implement the segment and details all allowances to be made to facilitate anticipated expansions to the network.

- Field Health Station
- ⊕ First Level Referral Center
- ⊖ Second Level Referral Center
- Switching Relay
- △ Repeater Relay
- Microwave Path Required this Segment
- Voice Channel Required this Segment
- - - Proposed or Existing Microwave Paths (not part of this segment)

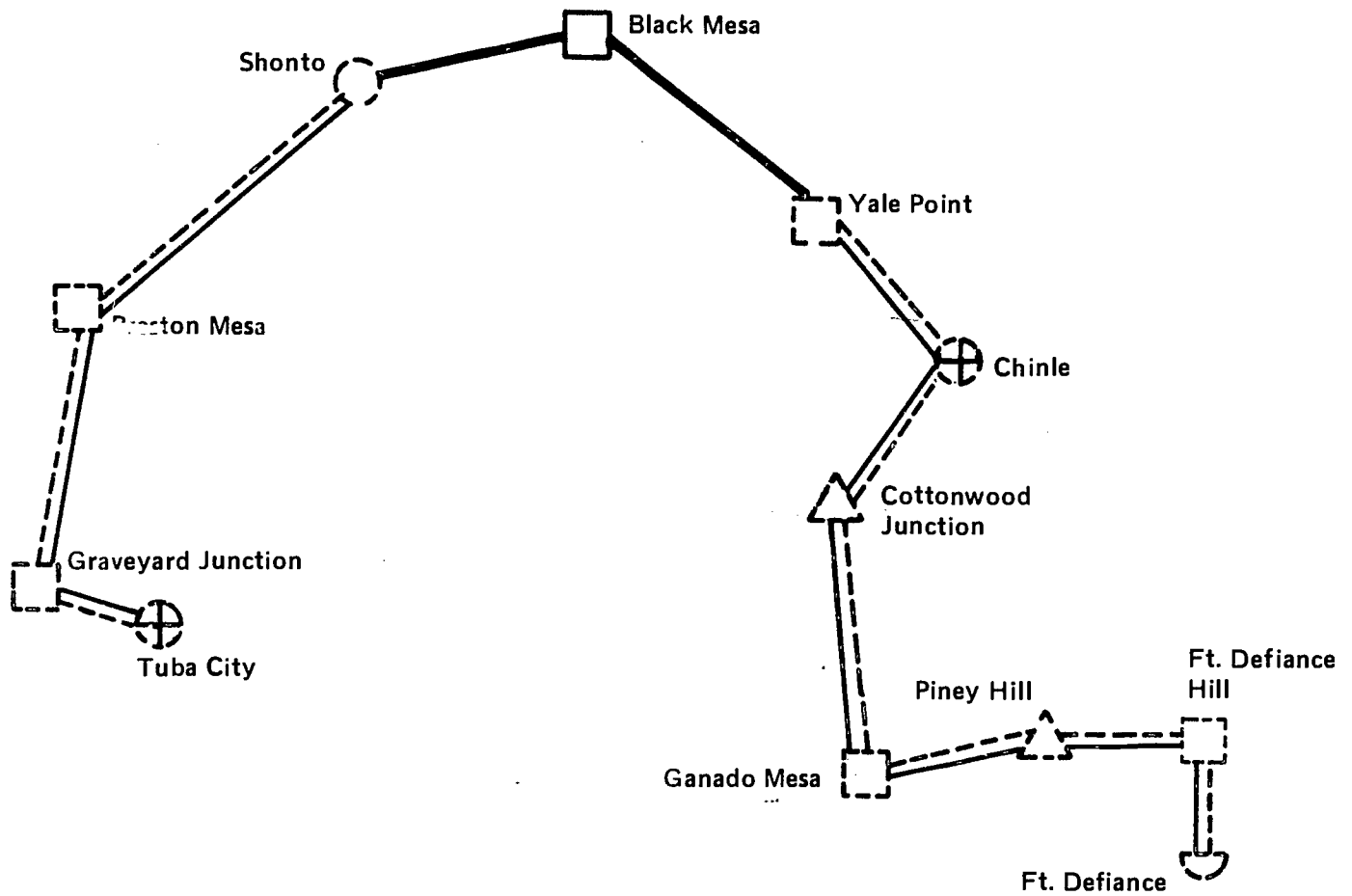

Figure 1.1. Tuba City, via Black Mesa, Ft. Defiance Segment.

2.0 SYSTEM DESIGN

2.1 Communications Channels

The full duplex microwave segment shall be channelized to carry the following services.

- Full color television (525 line/30 frame with 5.5 MHz bandpass) – one channel
- Program audio (15 kHz bandpass) – one channel
- Order wire (with selective signaling) – one channel
- “Voice” slots (FDM, 4 kHz spacing) – up to 12 channels
- Alarm circuits – see channelization plan.

A further breakdown of the use of the “voice” slots is included in the suggested spectrum utilization plans for each link within the segment (see Appendix D.1).

The designated voice slots are to be used for the following services:

- Camera positioning control (tilt, pan, focus, zoom, iris, mono/color) – six channels (dc control) per voice slot
- Teleprinter/keyboard (300 baud) – six channels per voice slot, one channel per site
- Telemetry (IRIG Standard) dc to 500 Hz – one channel, single voice slot per site
- Slow-scan television (approximately one frame per two-minute interval) – one channel, single voice slot
- Switching control (relay sites, remote) – touch tones, share administrative voice slot

Locations in the network shall be provided with modems, FSK transmitter/receivers, FM telemetry devices and such required interface equipment so as to facilitate these services at each terminal site.

2.2 Selection of Microwave Routes

The suggested sites for this segment are described as follows. Path profiles, site maps, photographs and drawings are provided in Appendices A, B, C and D, respectively.

Shonto

This is a previously developed site of the Arizona TeleMedicine Network. At this site the Contractor shall install the radio equipment, antenna and switching and control equipment necessary to complete the link to Black Mesa. A suitable tower, rack space and power shall be considered to be available at this site.

Black Mesa

This site is a developed radio site of the Navajo Communication Company, Inc. . sharing agreement shall be sought. The Contractor shall install a new tower, equipment building and all necessary equipment. The site plan is shown in Figure D.3. The proposed tower is shown in Figure D.10.

Yale Point

This site is a developed radio site of the Navajo Communication Company, Inc., and also a developed site of the Arizona TeleMedicine Project. A suitable tower and equipment building with rack space and power shall be considered to be available. The Contractor shall install the antenna, radio equipment and switching and control equipment necessary to complete the link from Black Mesa.

2.3 Control of Signal Switching

In this segment of the Arizona TeleMedicine Network, the following control and switching relationships shall prevail:

Switching Relay	Control Station
Shonto	Tuba City
Black Mesa	Kayenta
Yale Point	Chinle

Refer to System Procurement Specifications document for general discussion of switching concepts.

The various switch configuration for each switch point are described in the following paragraphs. Note that blank panels are to be provided for switching functions which will be added as the network expands. However, if a portion of a switch matrix is to be used in this segment, the entire matrix shall be installed. Only the switch positions specifically called for in this segment are to be wired.

Each Class "b" or Class "c" station will have installed, when applicable, as an integral part of its control panel, a group of illuminated push buttons which control the origin of the station's switching control tones. These tones will be generated by oscillator modules that produce the dual frequency notes commonly called "touch tones." Depending on which set of tones is generated over which Administrative Voice Channel, a particular cross point on a matrix located at a remote switching relay station will be energized. The administrative voice channel control is installed in the console.

2.3.1 Shonto Switch Point (Class "a" Station)

General

At this site for this segment one transmitter/receiver (T/R) pair¹ is brought together for switching. It is listed below:

Black Mesa: This T/R pair links the switching relay at Shonto with the switching relay at Black Mesa.

¹Up to two transmitter/receiver pairs will have been added as the network expands. Allowance shall be made for rack space and power requirements.

In remote command of the various switch configurations at Shonto is Tuba City, a Class "b" station.

The control tones originated by Tuba City used to actuate the Shonto switching equipment are carried via the Tuba City to Ft. Defiance administrative voice channel. In general, each transmit and receive circuit of the duplex link is switched separately. The Contractor shall complete the switch matrix at Shonto such that Tuba City can control the switching of the T/R pairs that come together at Shonto.

2.3.2 Black Mesa Switch Point (Class "R1" Station)

General

In this segment two transmit/receiver (T/R) microwave pairs¹ come together at the Black Mesa switching relay. They are listed below.

Shonto This T/R pair serves to link the Shonto switching relay with the Black Mesa switching relay.

Yale Point This T/R pair serves to link the Yale Point switching relay with the Black Mesa switching relay.

In remote command of the various switch configurations at Black Mesa is Kayenta, a Class "a" station to be added later. For this segment, these two (T/R) pairs do not require switching. Therefore the switching matrix and associated control equipment at Black Mesa shall not be installed as part of this segment. However, the Contractor shall install microwave radio equipment which will allow for switching at a future time.

2.3.3 Yale Point Switch Point (Class "R1" Station)

General

In this segment one transmitter/receiver (T/R pair)² comes together at the Yale Point switching relay. This pair is the link from Black Mesa.

¹Up to one transmitter/receiver pair will be added as the network is expanded. Allowance shall be made for rack space and power requirements.

²Up to three transmitter/receiver pairs will have been added as the network expands. Allowance shall be made for rack space and power requirements.

In remote command of the various switch configurations at Yale Point is Chinle, a Class "b" station which is implemented by another segment. The Contractor shall install all existing (T/R) pairs to the switch matrix at this time. The Contractor shall also install the necessary tone and control equipment required at Yale Point and Chinle.

2.3.4 Control Panel at Tuba City

A drawing of the switching and control panel at Tuba City is shown as Figure D.6. The drawing shows the switching requirement for the video, slow-scan TV and telemetry functions for control of the relay at Shonto. Other switching functions will be added as the network expands.

2.3.5 Administrative Voice Channel

The Contractor shall complete the AdVC circuit from Tuba City to Ft. Defiance. The control panel layouts are shown in Figure D.7 and D.8.

3.0

APPLICABLE DOCUMENTS

The Arizona TeleMedicine Network
System Procurement Specifications, May 1973.

3-1

191

APPENDIX A

PATH PROFILE

Note: When towers are not specified on the Vertical Earth Profiles, only minimum tower heights governed by antenna size, will be required.

Note: Corrections for earth curvature and Fresnel zone radius have been included on each profile:

Δ 0.3 first Fresnel zone radius

Δ earth curvature for $k = 2/3$

A-1

192

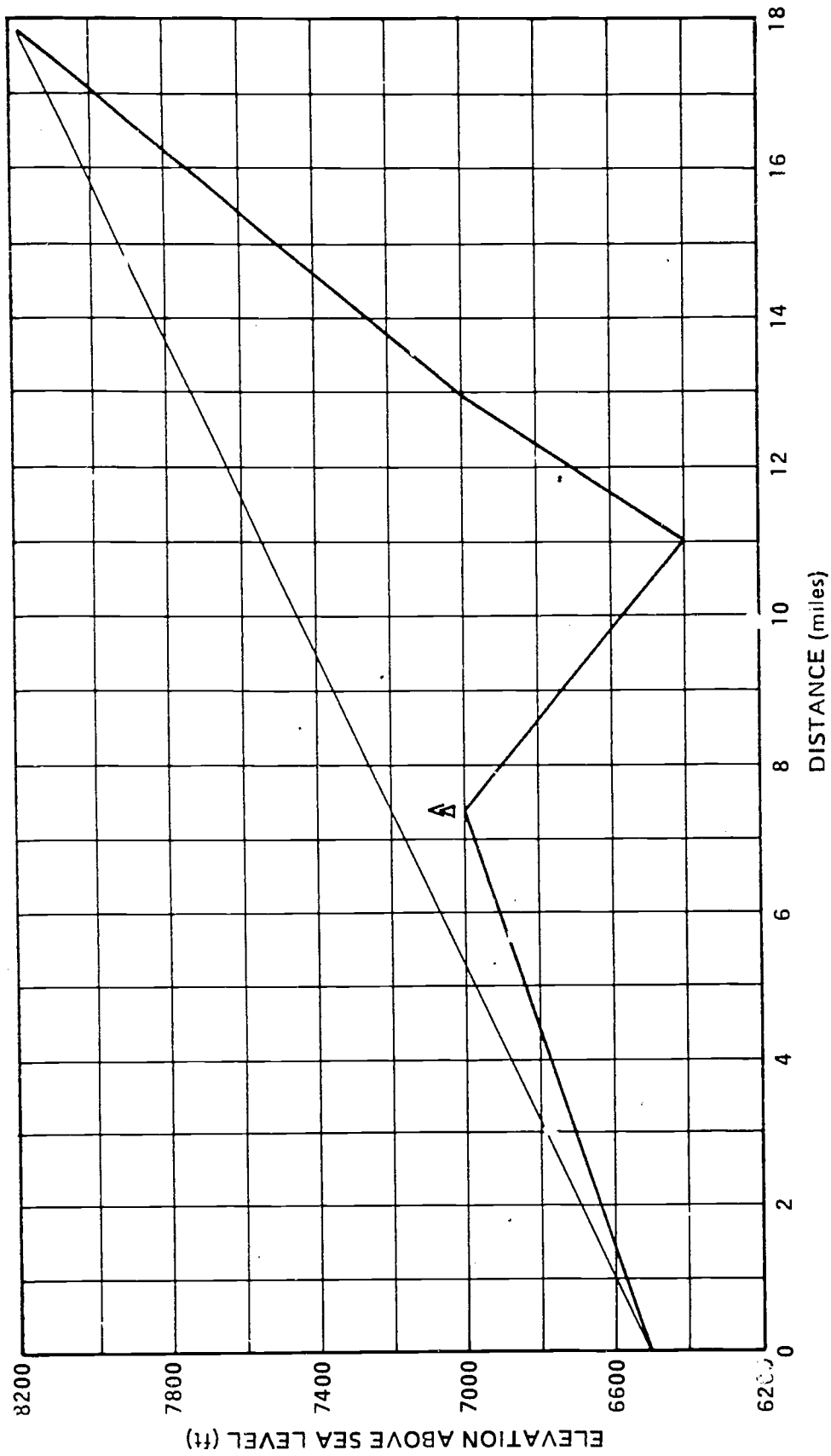

Figure A.1. Microwave Path Profile, Shonto to Black Mesa.

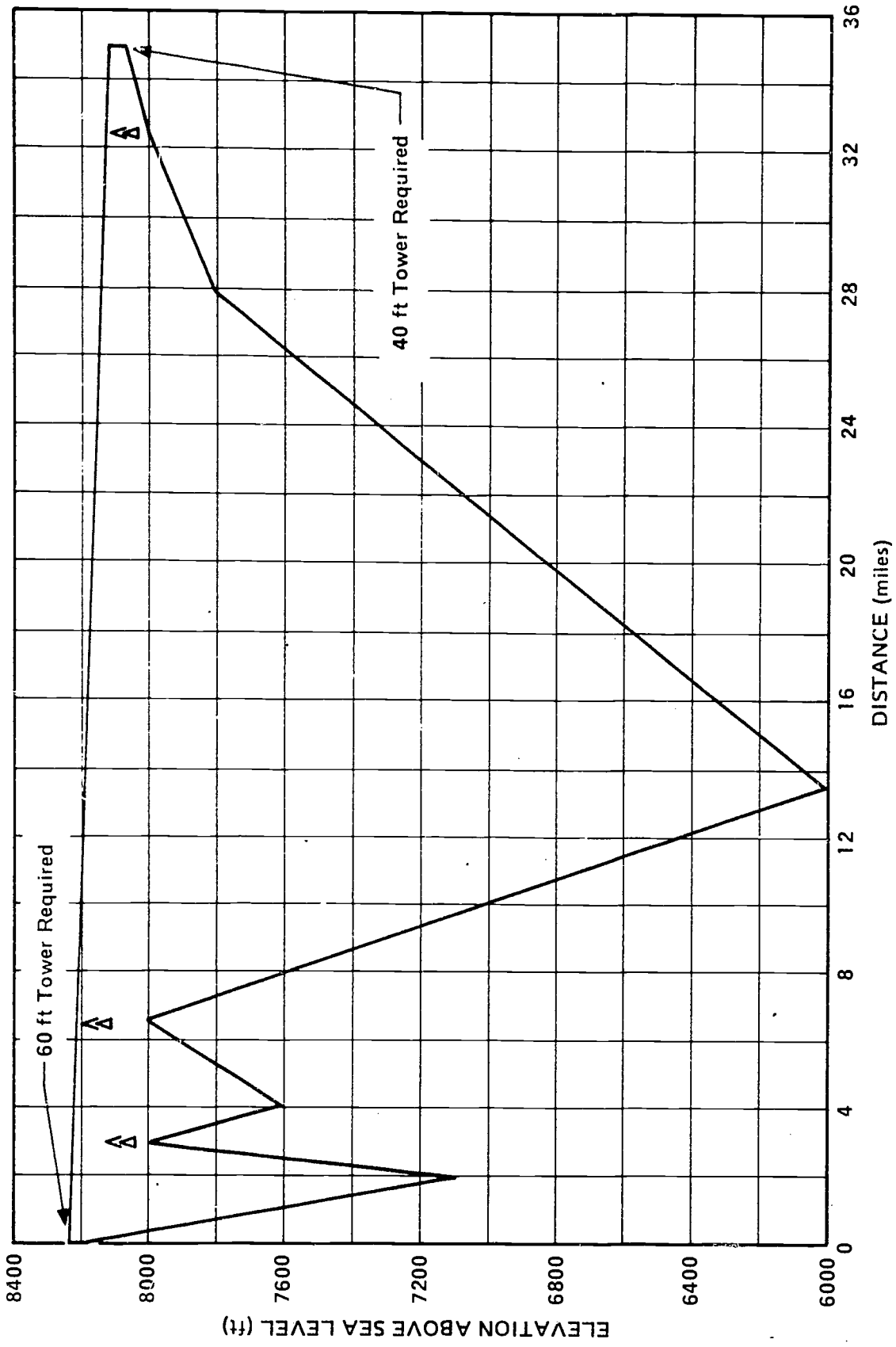

Figure A.2. Microwave Path Profile, Black Mesa to Yale Point.

APPENDIX B

SITE MAPS

B-1

195

pg. A-4 is blank.

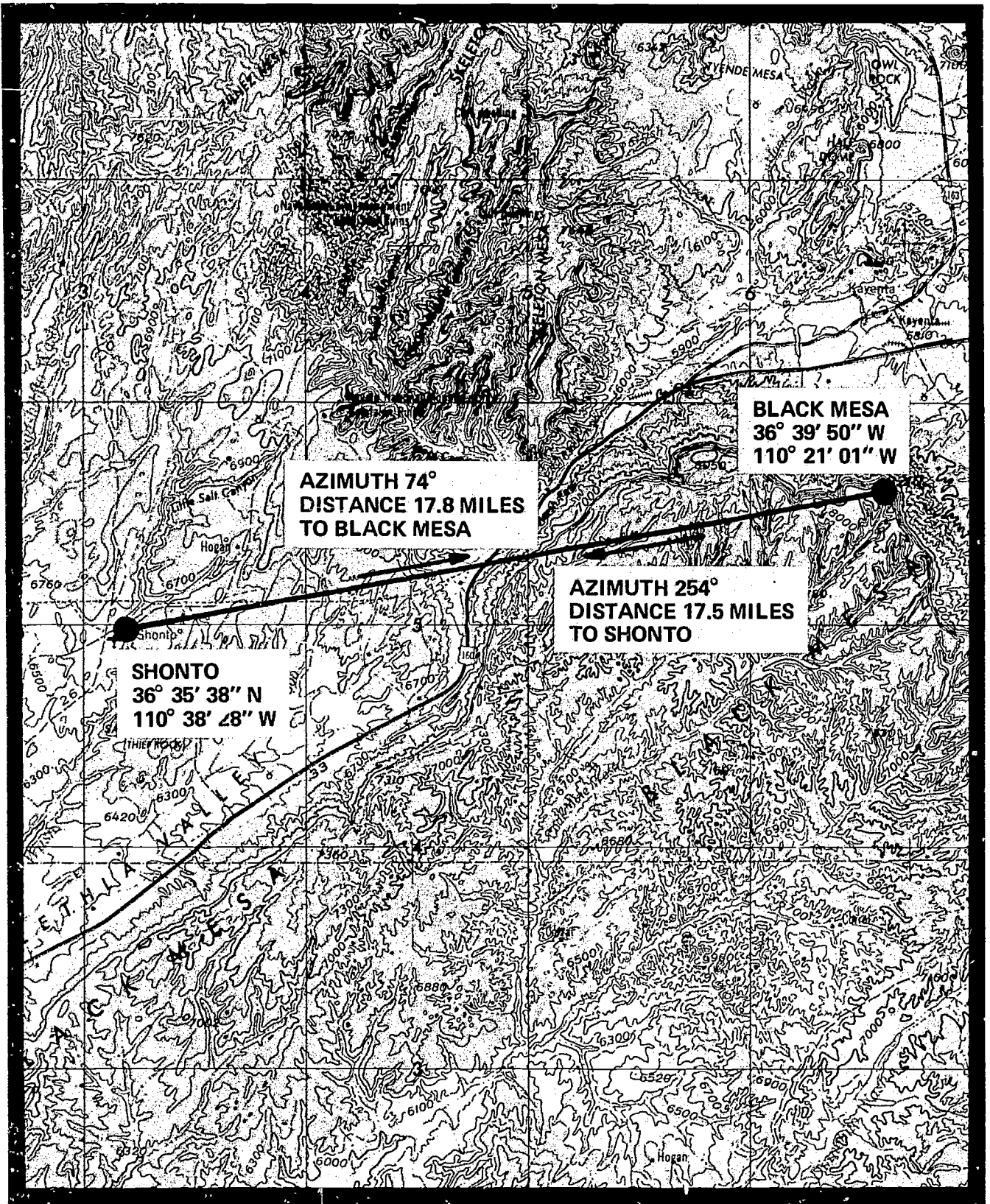

Figure B.1. Shonto and Black Mesa Site Map.

APPENDIX C

SITE PHOTOGRAPHS

G-1

page B-4 is blank



Figure C.1. Existing Microwave Facility at Shonto.

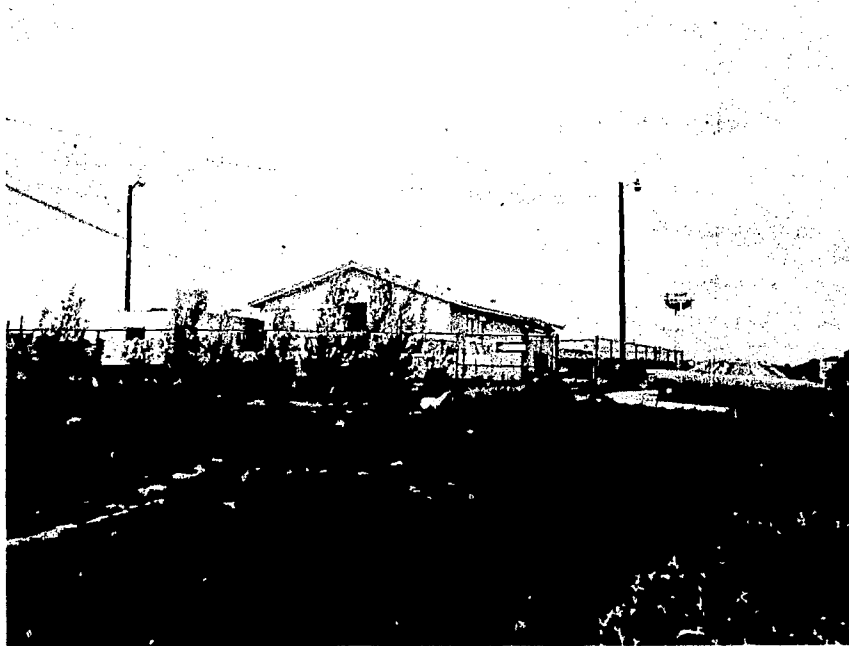

Figure C.2. Field Health Station at Shonto.

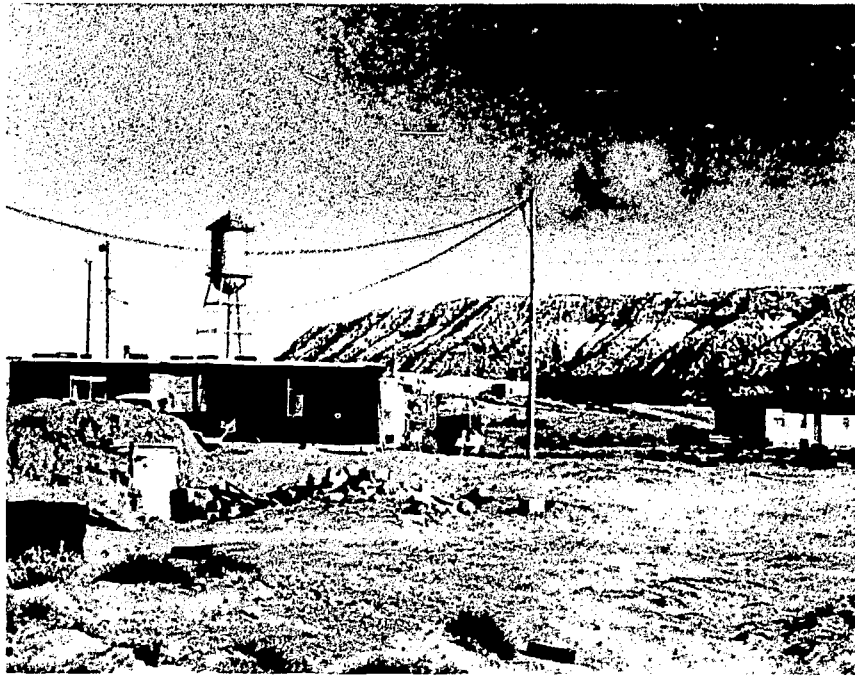

Figure C.3. View of Black Mesa Looking South from Highway Near Kayenta.

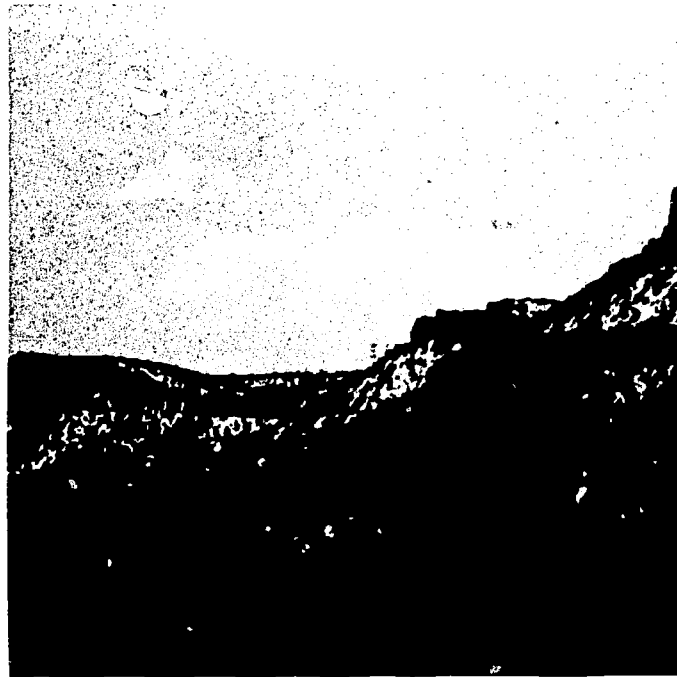

Figure C.4. View of Yale Point.

APPENDIX D

DRAWINGS

D-1

201

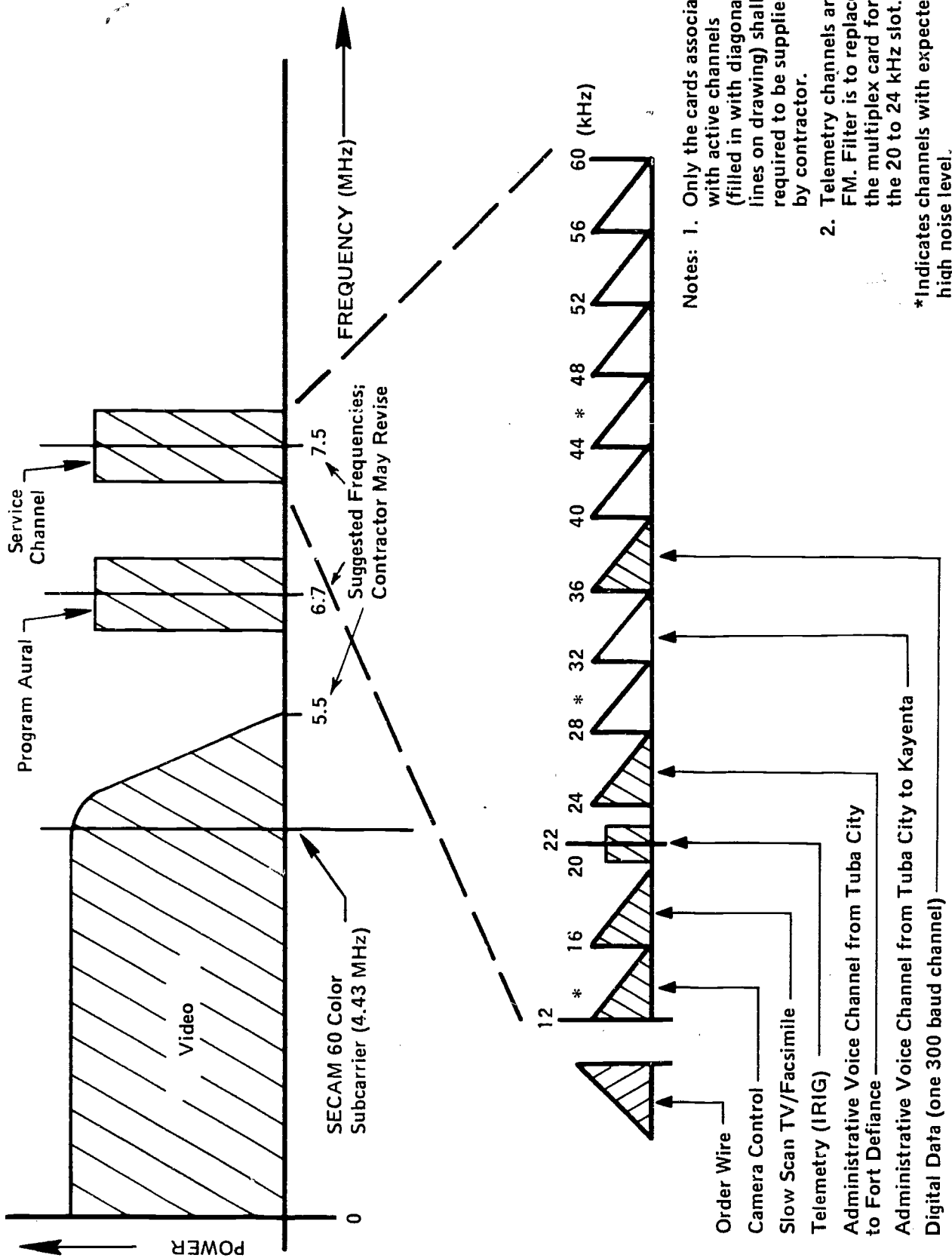

- Notes:
1. Only the cards associated with active channels (filled in with diagonal lines on drawing) shall be required to be supplied by contractor.
 2. Telemetry channels are FM. Filter is to replace the multiplex card for the 20 to 24 kHz slot.
- * Indicates channels with expected high noise level.

Figure D.1. Channelization Plan, Link from Shonto to Yale Point.

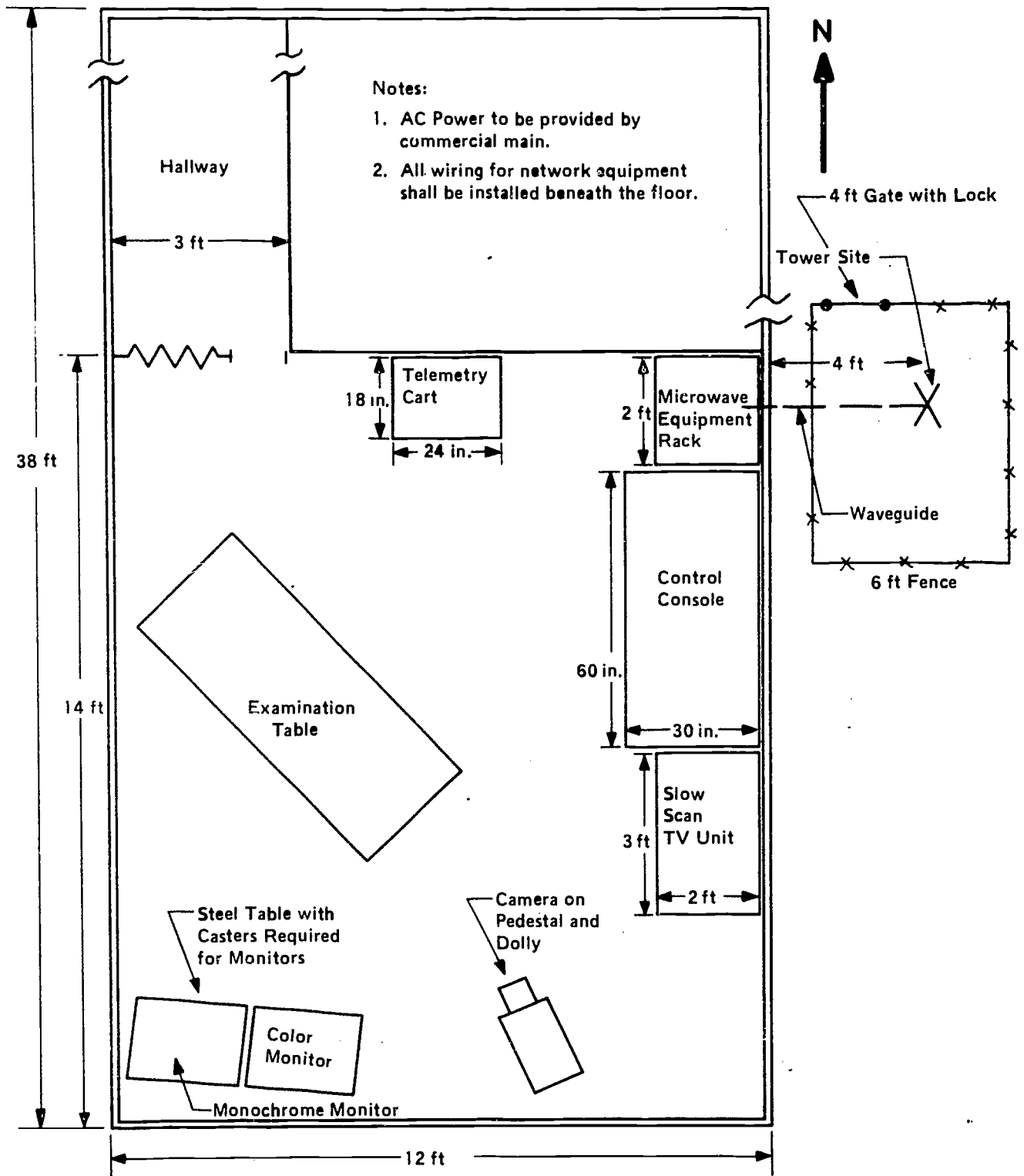
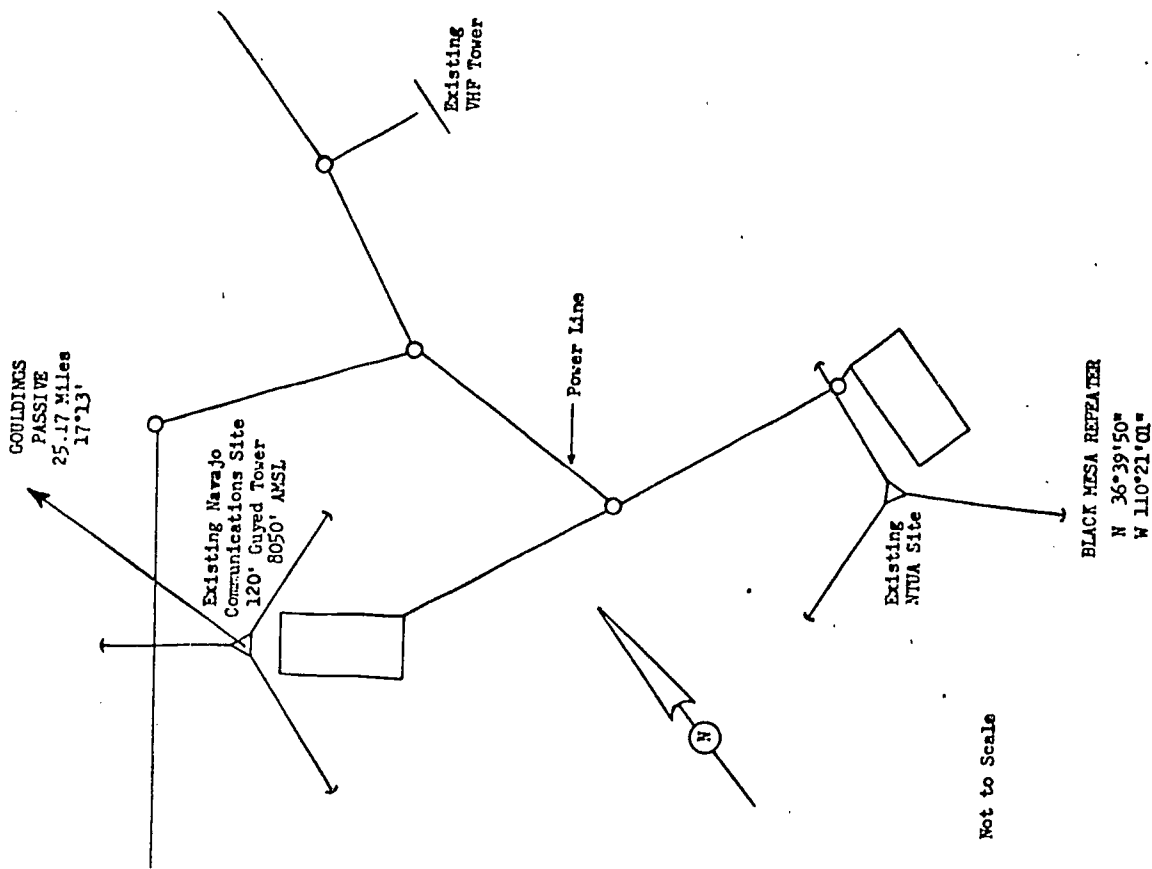
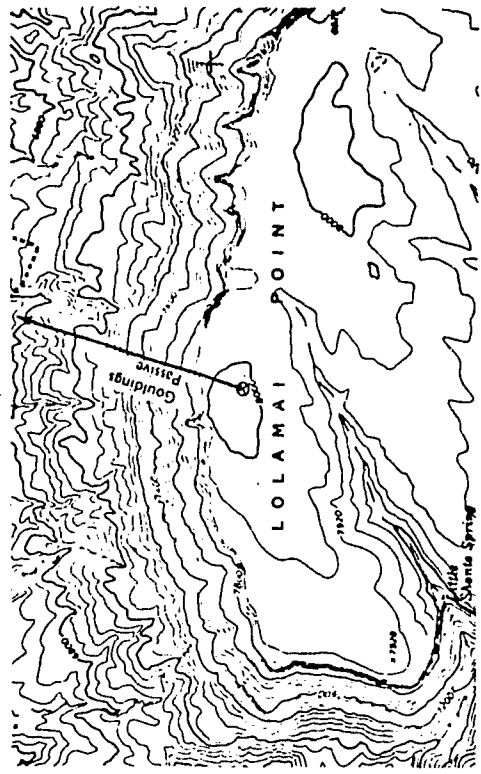

Figure D.2. Proposed Facilities at Shonto.



Not to Scale



BLACK MESA REPEATER
 The Black Mesa site is an existing Navajo Communications repeater. Access is poor during wet or snowy conditions. The existing tower and building should be adequate for the new radios to Monument Valley.

Figure D.3. Existing Facilities at Black Mesa (Navajo Communications Company).

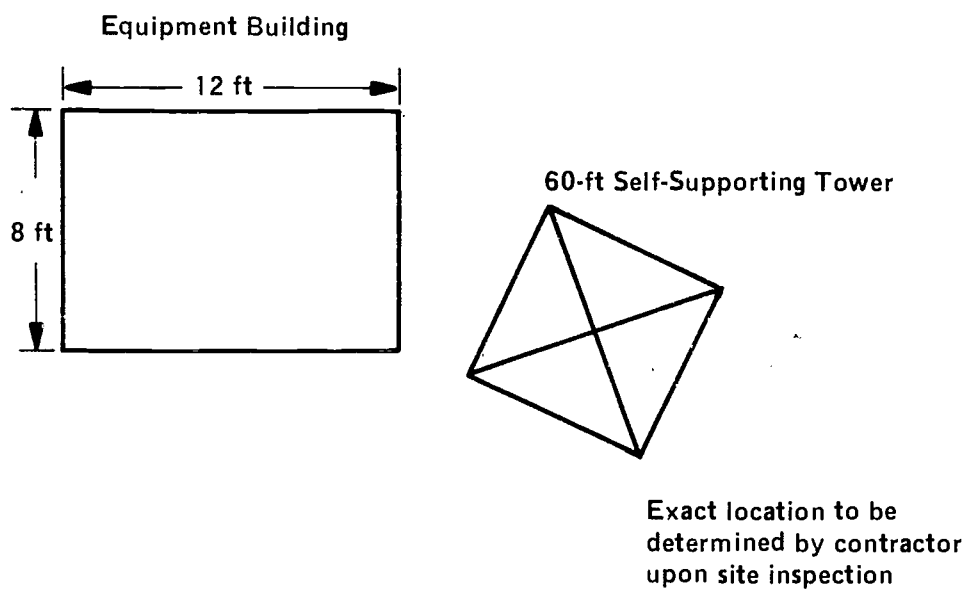

- Commercial Power Available
- Standby Power Required

Figure D.4. Proposed Facilities at Black Mesa.

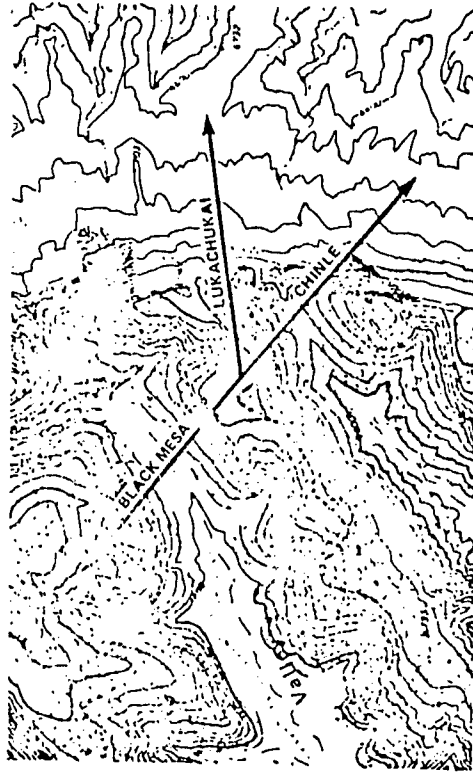
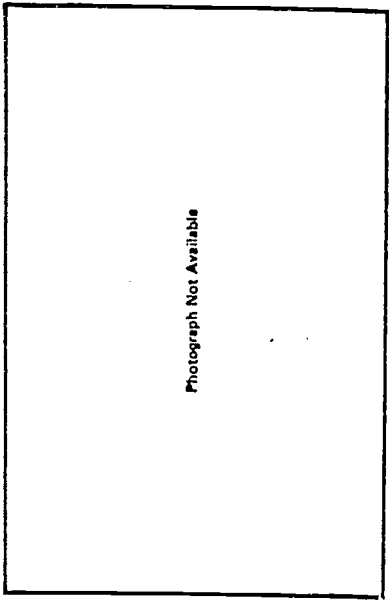

Yale Point Repeater

The Yale Point Repeater will be located adjacent to the existing BIA/NTUA microwave site 20 miles north west of Chinle, Arizona. Power is in to the site. Access is extremely poor during wet or snowy conditions. Soil conditions are extremely rocky. No clearing will be necessary but care should be taken to avoid guy wires of existing towers.

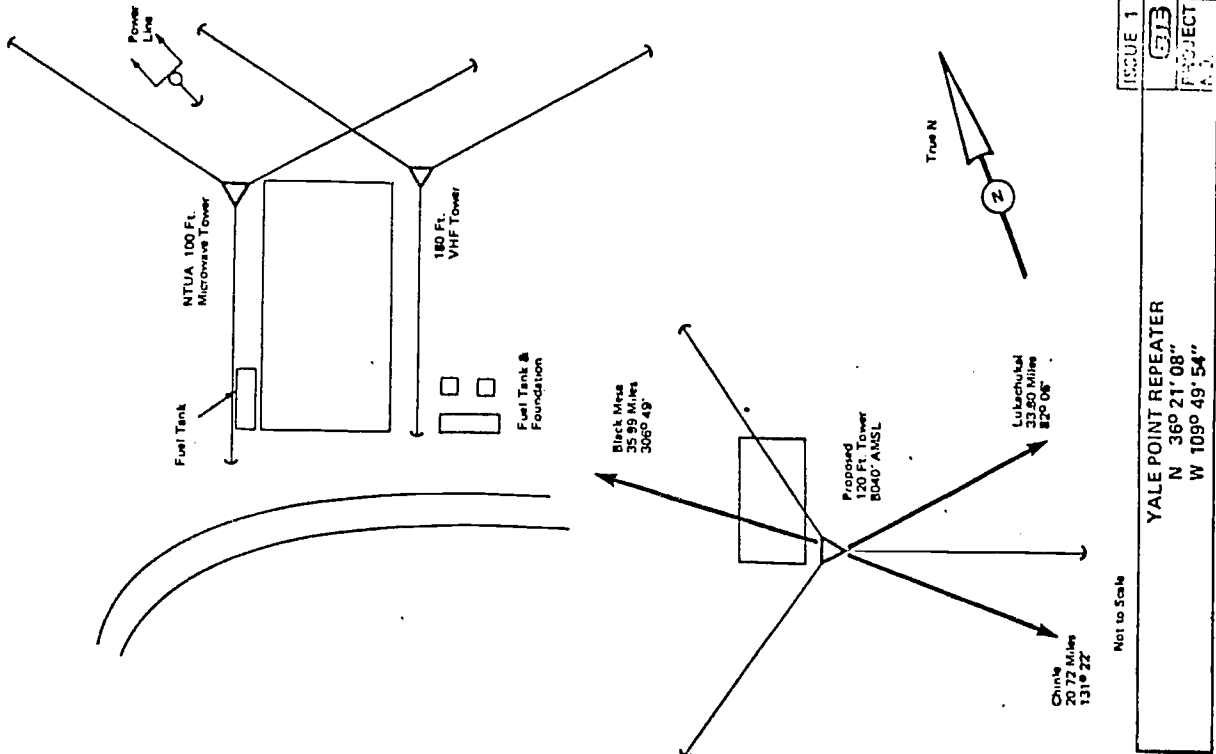
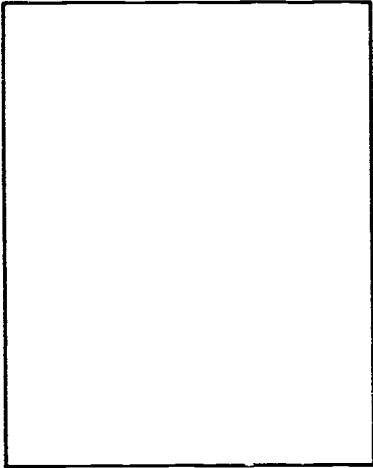
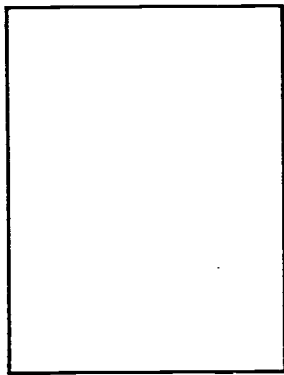

Figure D.5. Existing Facilities at Yale Point (Nav. Comm).

19"

VIDEO SWITCHING CONTROL



Shonto Matrix

RESET	BLACK MESA TO PRESTON MESA	SHONTO TO PRESTON MESA
RESET	PRESTON MESA TO BLACK MESA	SHONTO TO BLACK MESA
RESET	PRESTON MESA TO SHONTO	BLACK MESA TO SHONTO

SLOW-SCAN TV SWITCHING CONTROL

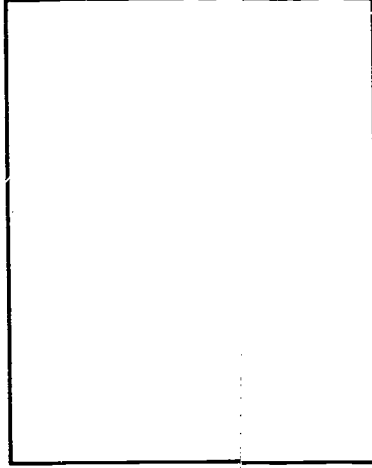
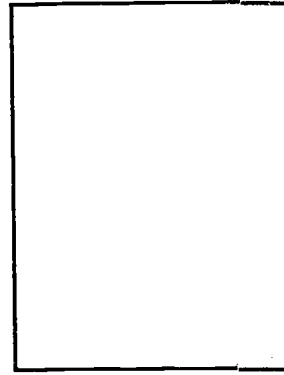

39"

D-7

207

Shonto Matrix

RESET	BLACK MESA TO PRESTON MESA	SHONTO TO PRESTON MESA
RESET	PRESTON MESA TO BLACK MESA	SHONTO TO BLACK MESA
RESET	PRESTON MESA TO SHONTO	BLACK MESA TO SHONTO

TELEMETRY SWITCHING CONTROL

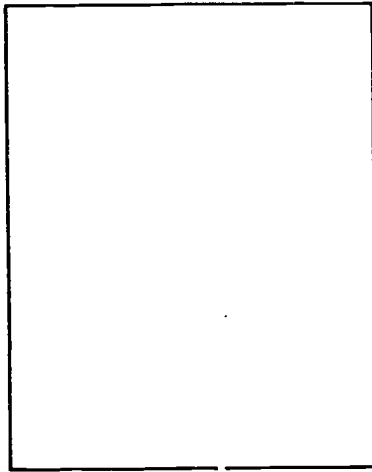
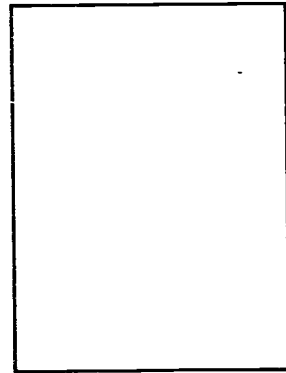

Shonto Matrix

RESET	BLACK MESA TO PRESTON MESA	SHONTO TO PRESTON MESA
RESET	PRESTON MESA TO BLACK MESA	SHONTO TO BLACK MESA
RESET	PRESTON MESA TO SHONTO	BLACK MESA TO SHONTO

Reserved/Spare

Figure D.6. Switching and Control Panel Layout at Tuba City.

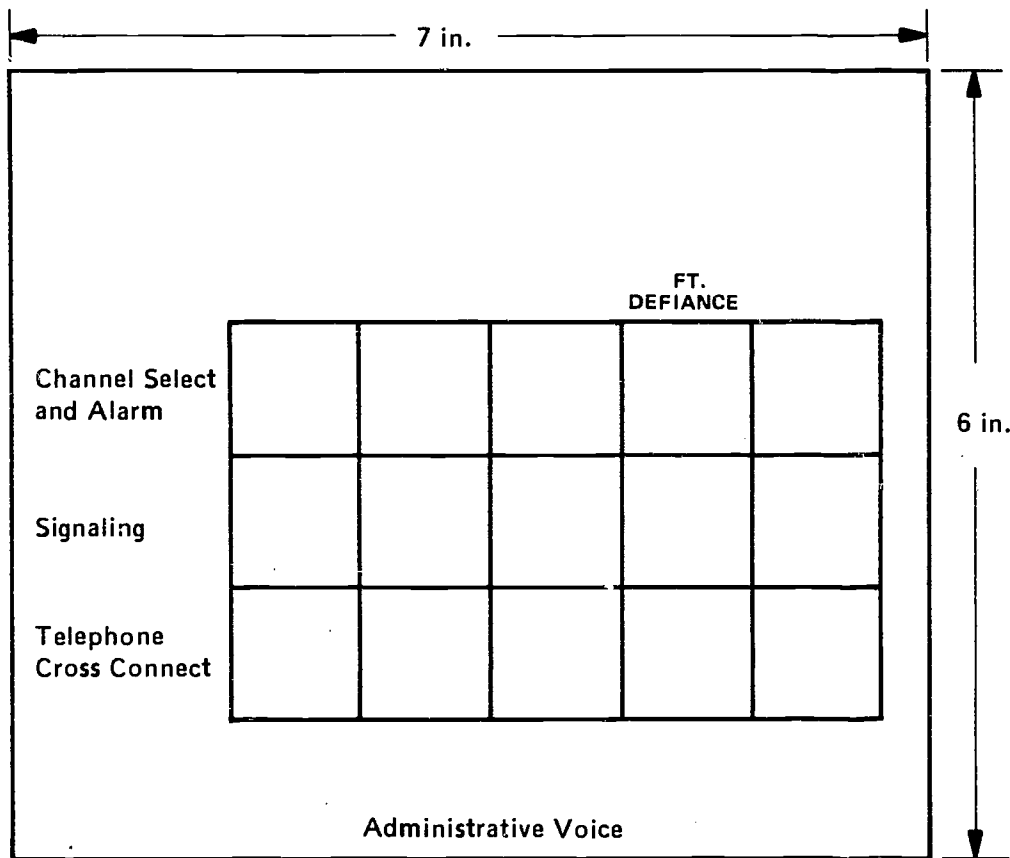

Figure D.7. Administrative Voice Channel Panel Layout at Tuba City.

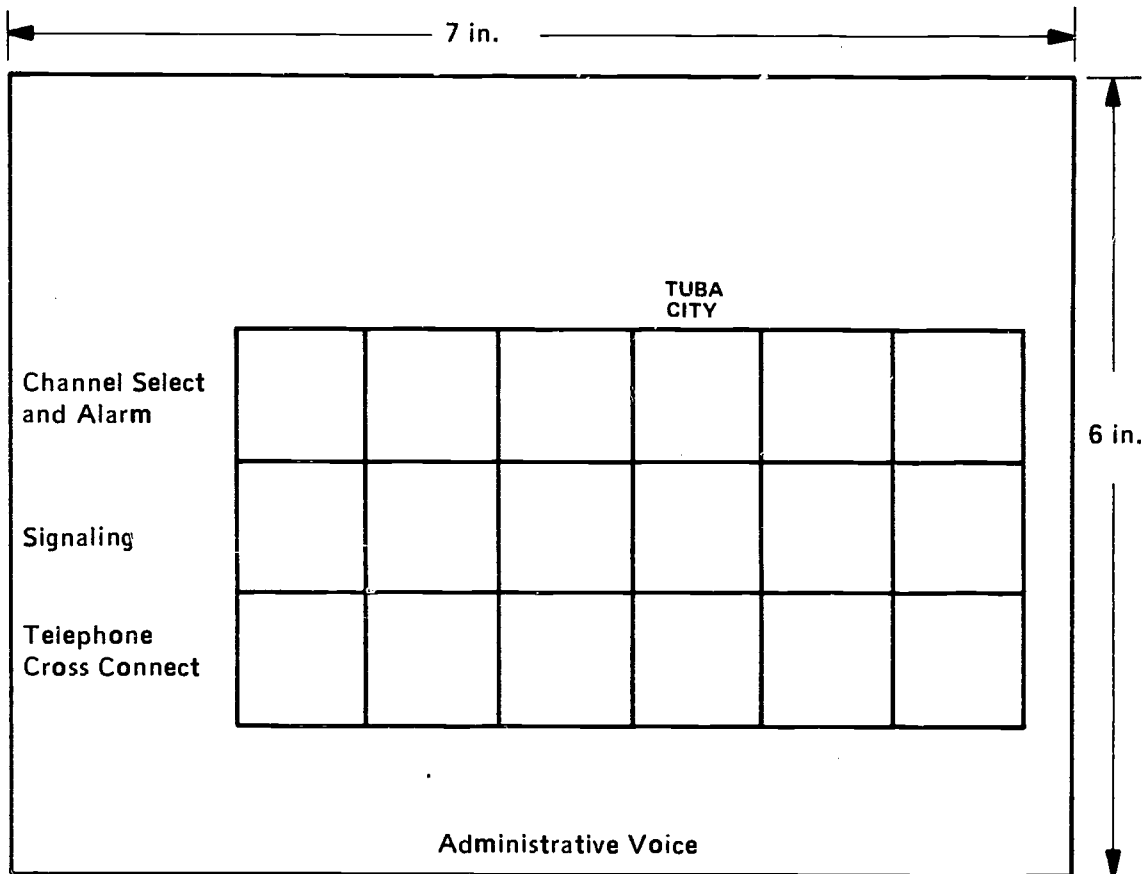

Figure D.8. AdVC at Fort Defiance.

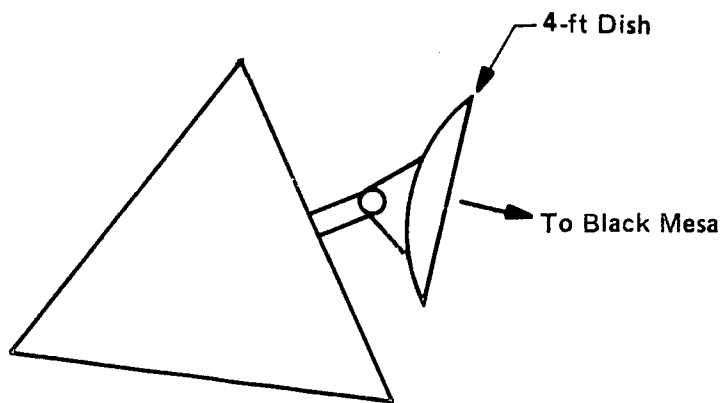
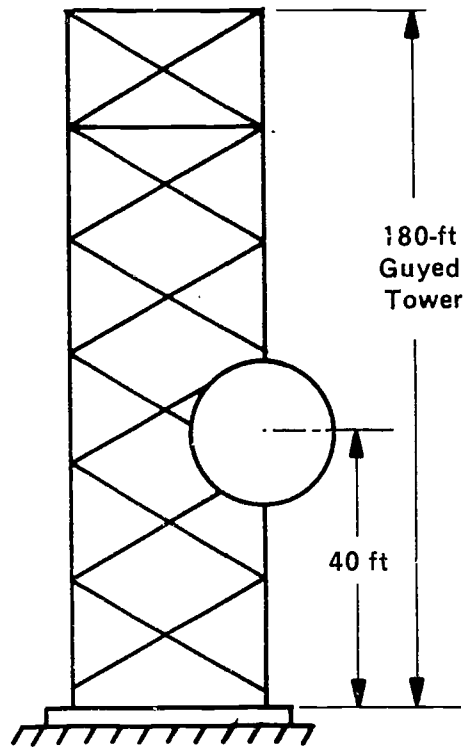

Figure D.9. Support Structure and Antenna Arrangement at Shonto.

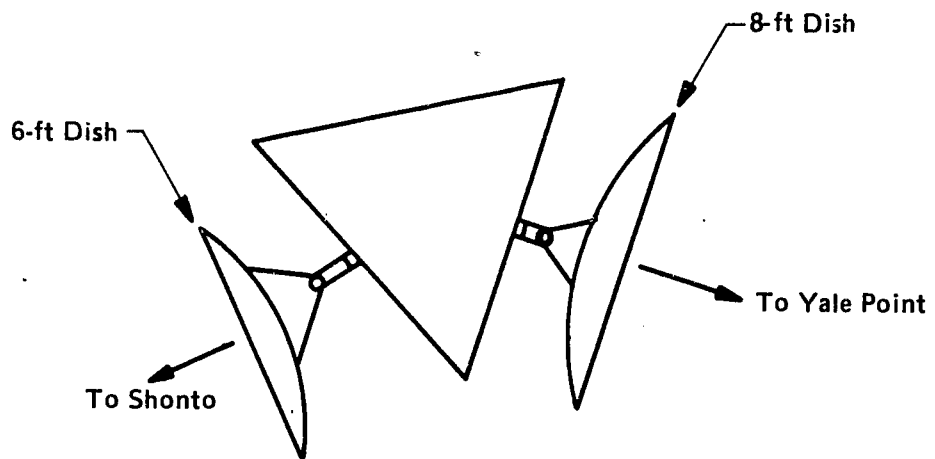
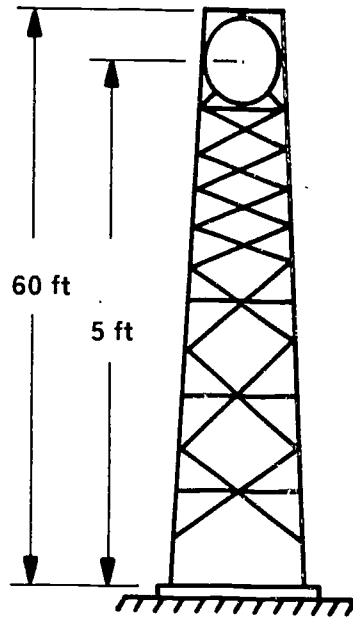
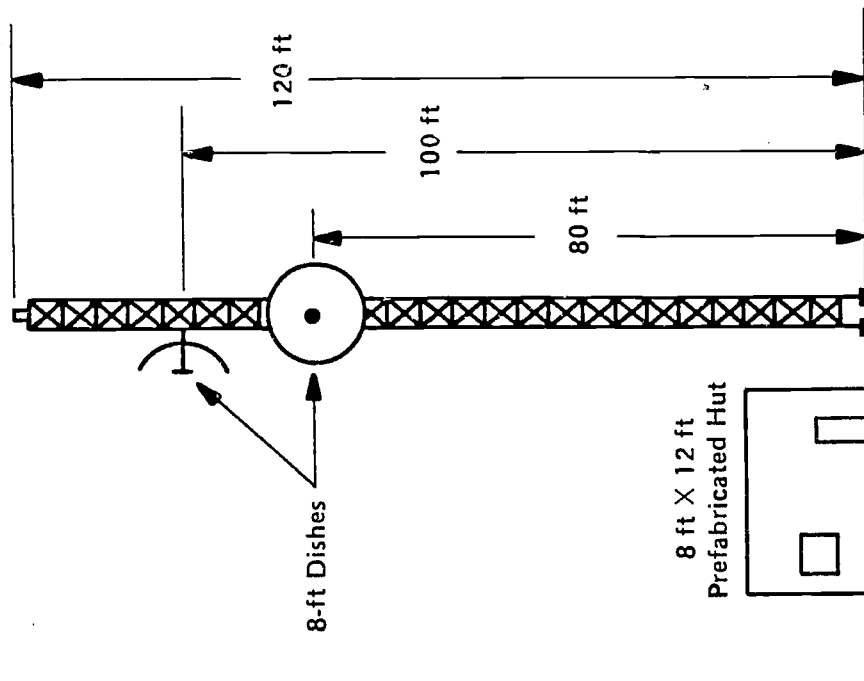

Figure D.10. New Tower and Antenna Arrangement at Black Mesa.



Antenna to be guyed according to manufacturer's recommendations to accommodate at least three additional 8-ft dishes near the top.

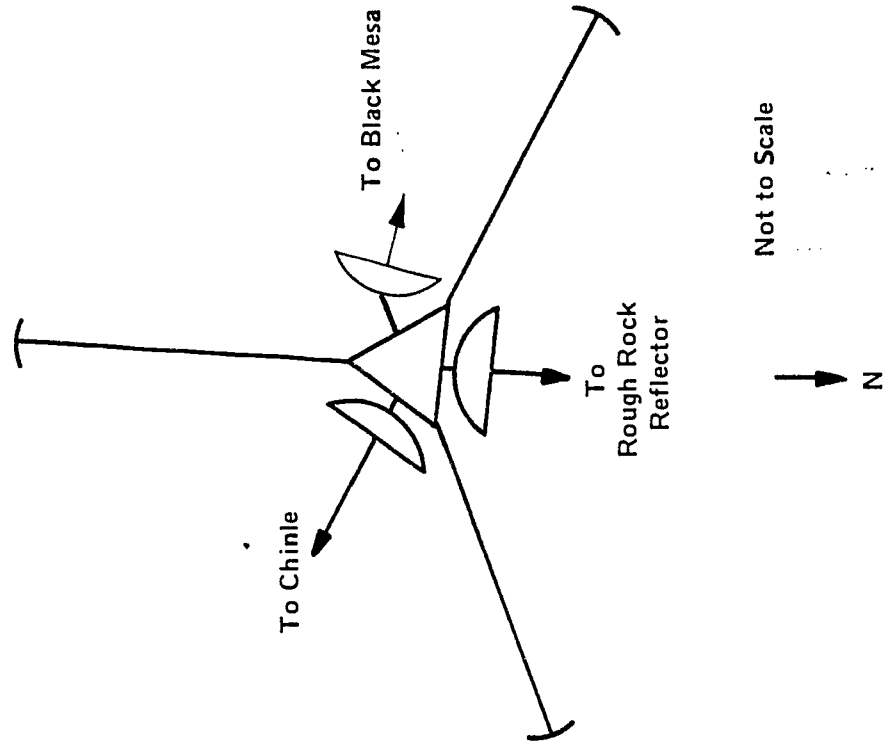

Figure D.11. New Tower and Antenna Arrangement at Yale Point.

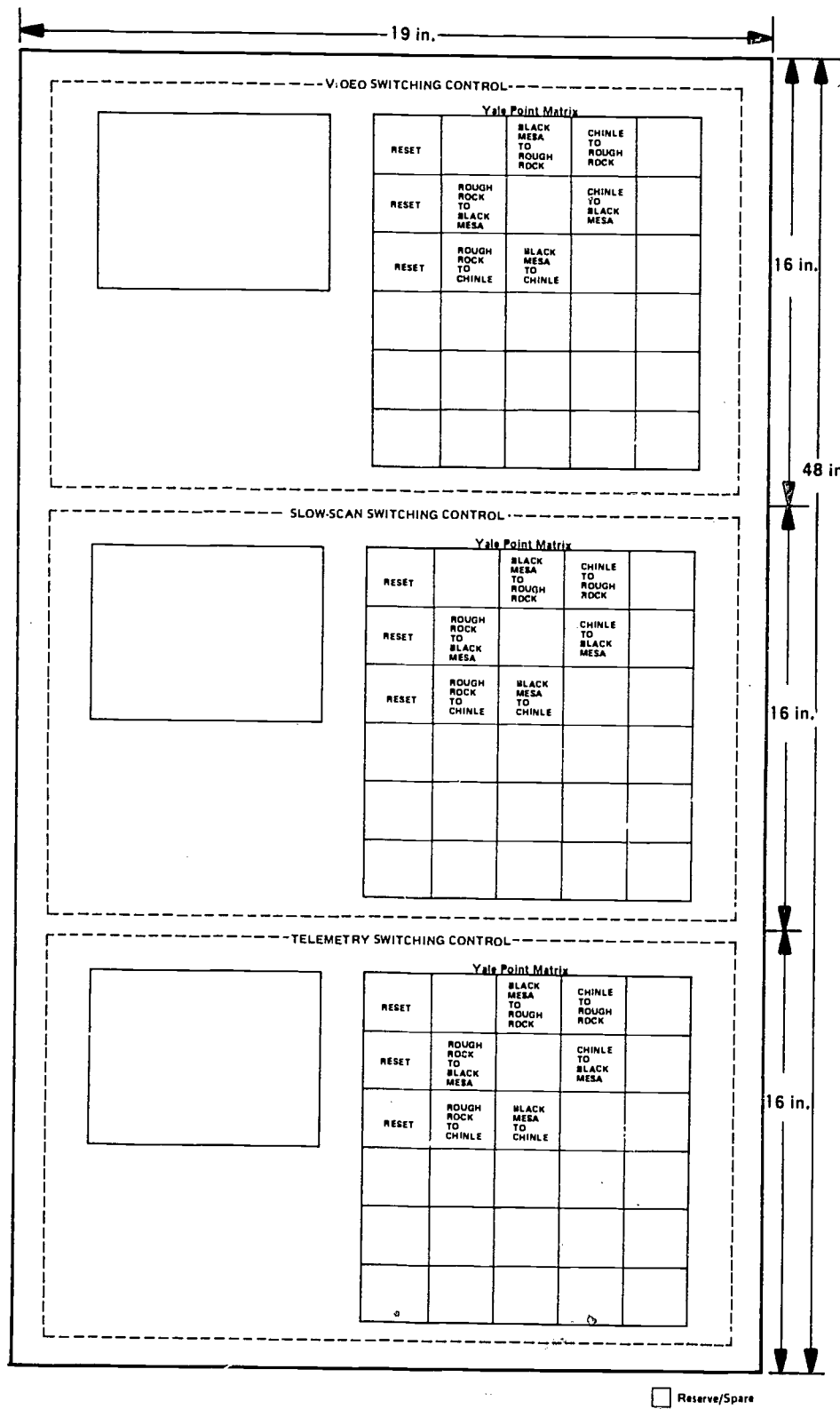

Figure D.12. Switching and Control Panel at Chinle.



THE ARIZONA TELEMEDICINE NETWORK

BUDGETARY COST INFORMATION

Pinal Peak, via San Xavier, Tucson

Prepared for:

**The University of Arizona College of Medicine
Department of Family and Community Medicine
Tucson, Arizona 85724**

Prepared by:

**The Biomedical and Special Systems Group
Telecommunications Activity
Atlantic Research Corporation
Alexandria, Virginia 22314**

May 30, 1973

215

RC 009027

TABLE OF CONTENTS

	Page
1.0 BUDGETARY COST INFORMATION	1
1.1 General	1
1.2 Capital Cost Summary	2
1.3 Operating Cost Summary	2
2.0 CAPITAL COST, MICROWAVE RADIO SYSTEM, PINAL PEAK VIA SAN XAVIER, TUCSON	3
3.0 TERMINAL EQUIPMENT COSTS	5
3.1 Class "a" Stations	5
3.2 Class "c" Station (Tucson)	5
4.0 SWITCHING AND CHANNEL EQUIPMENT FOR RELAY SITES	9
4.1 Pinal Peak Switching Relay	9
4.2 San Xavier Switching Relay	10
4.3 San Xavier Monitor	11
5.0 OPERATING COSTS	13

1.0 BUDGETARY COST INFORMATION

1.1 General

The budgetary estimates for the capital and operating cost requirements of a segment of the proposed Arizona TeleMedicine Network, are presented in this document.

In determining the cost of the segment the following items were considered:

Material and installation of:

Microwave radio equipment

Antennas and waveguides

Supporting structures

Equipment housing, fencing

Power generators

Switching and channel equipment

Terminal equipment

Frequency selection and application preparation

In addition, cost data for the maintenance function are provided in terms of capital cost for spare parts and test equipment. Allowances are made for various miscellaneous fees such as legal fees, construction permits, etc. The operating cost data presented, include the technical operation function only. Administrative costs are not part of this report. The technical items included are: technician salary, consumable spare parts, site rental fees, maintenance vehicle costs and other maintenance cost items.

1.2 Capital Cost Summary

In arriving at a budgetary capital cost estimate for the segment the following items were taken into account.

1. Microwave radio system	\$157,340
2. Terminal equipment	102,375
3. Optional business facsimile unit	5,250
4. Switching and channel equipment for relay sites:	56,742
5. San Xavier monitoring site	24,174
6. Slow-scan television unit (each terminal site)	23,000
7. Legal services	2,000
8. Allowance for subcontract to Medical Center Physical Resources Department for the wiring and conduit work required – (labor and conduit only)	2,500
9. Test equipment	20,000
10. Maintenance vehicles (one)	4,200
11. Spare equipment	<u>15,000</u>
Total Capital Cost	\$412,581

1.3 Operating Cost Summary

This cost reflects the salaries of one technician and the various expenses of maintaining the sites and equipment. It does not include any administrative functions or expenses.

Yearly Total Cost	\$ 34,000
-------------------	-----------

**CAPITAL COST, MICROWAVE RADIO SYSTEM,
PINAL PEAK VIA SAN XAVIER, TUCSON**

Material and Subcontract Labor	TUCSON		To San Xavier		SAN XAVIER		To Tucson		To Mt. Lemmon		MT. LEMMON		To San Xavier		To Pinal Peak		PINAL PEAK		To Mt. Lemmon		
	No.	Cost	No.	Cost	No.	Cost	No.	Cost	No.	Cost	No.	Cost	No.	Cost	No.	Cost	No.	Cost	No.	Cost	
Microwave Radio Equipment																					
Transmitters, 6 GHz									2	\$ 7,430					2	\$ 7,430					
Receivers, 6 GHz									2	7,200					2	7,200					
Transmitters, 12 GHz			2	\$ 8,400																	
Receivers, 12 GHz			2	8,300																	
Branching				1,200						1,200						1,200					
Power supply, 115 Vac				250						250					2	500					
Charger/regulator, 48V dc				910						910											
Battery, 48V				750						750											
Equipment racks		\$ 125			2	\$ 250						\$ 125						3	\$ 375		
Fault alarm insert transmitter						1,000						1,000							1,000		
Local alarm display panel		100				100						100							100		
Master fault alarm display panel		3,000																			
Factory wiring				170						170						170					
Shipping and handling		162		675		70				675		62				600					74
Installation and test		1,000		2,000		500				2,000		500				2,000					500
Antennas, Reflectors and Waveguides																					
4-ft diameter antenna, 12 GHz			2	1,106																	
6-ft diameter antenna, 6 GHz									2	1,416											
10-ft diameter antenna, 6 GHz																					
Waveguide, 12 GHz			116	452											2	3,911					
Waveguide, 6 GHz									121	581					113	543					
Waveguide connector, 6 GHz									4	180					4	180					
Waveguide connector, 12 GHz			4	264																	
Pressure window, 6 GHz									2	32					2	32					
Pressure window, 12 GHz			2	32																	
Waveguide grounding kit			4	20					4	20					4	20					
Wall feed-through, 6 GHz									2	58					2	58					
Wall feed-through, 12 GHz			2	66																	
Waveguide hanger and adapter kit			4	158					4	158					4	158					
Nitrogen tanks and fittings		150				150						150									150
Gas distribution manifold						87						55									91
Shipping and handling		8		400		11				600		11				1,000					13
Supporting Structures and Installation																					
8-ft roof-mounted tripod		175																			
Tripod footing		1,000																			
30-ft self-supporting three-legged tower												900									
40-ft self-supporting three-legged tower						2,000															2,450
40-ft self-supporting four-legged tower																					600
Tower footing						600						600									4,050
Installation of tripod/towers/antennas and waveguide		700				3,200						1,700									4,050
Soil suitability consultation						750						750									750
Shipping and handling		9				300						300									300
Power Generators																					
Motor-generator																					1,100
Prime-emergency power switch																					900
Installation																					250
Shipping and handling																					300
Equipment Housing, Power Line and Fence																					
Shelter						1,960															
Fence						300															
Power connection						30															
Extraordinary transportation charges																					700
Installation						400															
Shipping and handling						515															
Miscellaneous Services																					
Frequency selection and FCC application preparation				500						500						500					
Specification writing and procurement				2,000						2,000						2,000					
Installation supervision and documentation				2,000						2,000						2,000					
SUBTOTAL		\$ 6,429		\$29,653		\$12,203				\$28,130		\$ 6,253				\$29,501					\$13,703
25 percent G & A		1,607		7,413		3,051				7,032		1,563				7,375					3,426
TOTAL		\$ 8,036		\$37,066		\$15,254				\$35,162		\$ 7,816				\$36,876					\$17,129

Total Materials and Labor \$125,872
 Contractor's G & A and Fee 31,469
GRAND TOTAL \$157,340

3.0 **TERMINAL EQUIPMENT COSTS**

3.1 **Class "a" Stations**

Not applicable to this segment.

3.2 **Class "c" Station (Tucson) (itemized below) \$102,375**

Console:

<u>Item</u>	<u>Quantity</u>	<u>Description</u>	<u>Unit</u>	<u>Cost</u>
1	1	Dual 9-inch monochrome monitors	\$ 935	\$ 925
2	1	Four-channel audio mixer	850	850
3	1	Audio Limiter	695	695
4	2	Lavilier microphones	90	180
5	1	Desk microphone	110	110
6	2	Three-button passive video switches	130	260
7	1	Cartridge video recorder with spare tape	1,700	1,700
8	1	Remote control for video recorder	175	175
9	1	Four-channel audio tape logger	1,500	1,500
10	1	Remote control for logger	150	150
11	1	Two-channel video D.A.	1,175	1,175
12	1	Video image enhancer	3,600	3,600
13	1	Program channel mod/demod	1,600	1,600
14	1	Service channel mod/demod	2,500	2,500
15	1	Multiplex card cage and common equipment	1,200	1,200
16	1 set	Multiplex channel cards	2,250	2,250
17	1	Wireless headset unit	300	300
18	1	Monitor headset	35	35
19	1 set	FSK demodulators/modulators	2,475	2,475

Console (continued):

<u>Item</u>	<u>Quantity</u>	<u>Description</u>	<u>Unit</u>	<u>Cost</u>
20	1	FSK rack and power supply	\$3,225	\$ 3,225
21	1	22 kHz telemetry transmitter	3,225	3,225
22	1	22 kHz telemetry receiver	2,525	2,525
23	1	AdVC audio select panel	250	250
24	1	Conference bridge/amplifier	375	375
25	1	Electric power breaker panel	150	150
26	1	Handset, four-wire, coil cord	20	20
27	1	Audio patch panel with accessories	75	75
28	1	Video test panel with accessories	125	125
29	1	Remote signal and alarm	75	75
30	1	Custom desk and frame	750	750
31	1	Desk chair	50	50
32		Miscellaneous wire, cable, connectors, equipment		1,500
		Subtotal, material		<u>\$34,025</u>
		Labor (includes engineering, console fabrication and installation of all console equipment and components)		7,500
		Shipping and handling (5% of materials)		1,701
		Contractor's G&A/fee (25% of all items above)		<u>10,807</u>
		Total per site		<u>\$54,033</u>

Component Subsystems:

<u>Item</u>	<u>Quantity</u>	<u>Description</u>	<u>Budgetary Cost</u>
1	1	Color monitor with accessories	\$ 1,200
2	1	Large monochrome monitor, etc.	750
3	1	Color television camera, complete (with sync generator and encoder)	29,000
4	1	Tilt/pan equipment for camera	1,500
5	1	Teleprinter/keyboard unit	2,900
6	1	Business facsimile unit ¹	4,000
7	1 set	Auxiliary lights	350
8	1	EKG machine and interface	1,600
9	1	Spirometer and interface	1,050
10	1	Electronic stethoscope	525
11		Allowance for cabling and miscellaneous materials	500
		Subtotal, materials	<u>\$ 43,375</u>
		Labor (including subcontracts, engineering and installation)	4,500
		Shipping and handling (5% of all material except color camera)	719
		Contractor's G&A/fee (25% of all items except color camera)	<u>4,898</u>
		Total per site	\$ 53,492
		Total (without facsimile)	\$ 48,242
		Grand total, Class "b" and "c" terminal site, equipment installed (per site figures, not including facsimile, clinical furniture, etc.)	<u>\$102,375</u>
		Tucson	

¹Optional.

4.0

SWITCHING AND CHANNEL EQUIPMENT FOR RELAY SITES

The following budgetary costs represent the total material and labor for the installation of the routing switchers, channel equipment and tone demodulators at each relay site. Also included in the cost is the switching tone generators and associated equipment at the Class "b" and Class "c" sites.

4.1 Pinal Peak Switching Relay (itemized below) \$16,031

<u>Item</u>	<u>Quantity</u>	<u>Description</u>	<u>Budgetary Cost</u>
1	1	Program mod/demods (audio)	\$ 1,600
2	1	Service channel mod/demods	2,500
3	1	Multiplex card cage and common equipment	1,200
4	1	Multiplex cards	2,250
5	1	22 kHz filters	300
6		Video switch matrix (addition)	350
7		Audio switch matrix (addition)	500
8		Control panel (addition)	425
9		Audio patching equipment	75
10		Video patching equipment	100
11		Miscellaneous material	200
		Subtotal, material	<u>\$ 9,500</u>
		Labor (including engineering, installation)	2,850
		Shipping and handling (5% of materials)	475
		Contractor's G&A/fee (25% of all items above)	<u>3,206</u>
		Total	\$16,031

4.2 San Xavier Switching Relay (itemized below) \$40,711

<u>Item</u>	<u>Quantity</u>	<u>Description</u>	<u>Budgetary Cost</u>
1	2	Program mod/demods (audio)	\$ 3,200
2	2	Service channel mod/demods	5,000
3	2	Multiplex card cage and common equipment	2,400
4	2 sets	Multiplex cards	4,500
5	2	22 kHz filters	600
6	1	Video switch matrix	1,500
7	2	Audio switch matrix	2,000
8		Control panel	1,200
9		Tone control equipment	2,800
10		Audio patching equipment	75
11		Video patching equipment	100
12		Miscellaneous material	750
		Subtotal, material	<u>\$24,125</u>
		Labor (including engineering, installation)	7,238
		Shipping and handling (5% of materials)	1,206
		Contractor's G&A/fee (25% of all items above)	<u>8,142</u>
		Total	<u>\$40,711</u>

4.3 **San Xavier Monitor (itemized below)** **\$24,174**

<u>Item</u>	<u>Quantity</u>	<u>Description</u>	<u>Budgetary Cost</u>
1		Program mod/demods (audio)	\$ 1,600
2		Service channel mod/demods	2,500
3		Multiplex card cage and common equipment	1,200
4		Multiplex cards	2,500
5		22 kHz filters	
6		Video switch matrix	350
7		Audio switch matrix	500
8		Control panel	425
9		Tone control equipment, monitor and cable link allowance	4,500
10		Miscellaneous material	750
		Subtotal, material	<u>\$14,325</u>
		Labor (including engineering, installation)	4,298
		Shipping and handling (5% of materials)	716
		Contractor's G&A/fee (25% of all items above)	<u>4,835</u>
		Total	<u>\$24,174</u>

5.0 OPERATING COSTS

For this segment Arizona TeleMedicine Network, as planned, the following minimum operating costs may be budgeted. Administrative costs are not itemized.

Staff salaries (technical operation) ¹	\$12,000
Overhead (75% of salaries)	9,000
Electric power ²	2,000
Bonds, insurance, miscellaneous ³	4,000
Consumable spare equipment/materials ⁴	1,200
Vehicle costs ⁵	1,200
Contract and professional service ⁶	2,800
Site rental fees ⁷	1,800
Total, Operating Costs	<u>\$34,000</u>

¹Based on one technician.

²Based on \$500 per site per year, including gas.

³Based on \$1,000 per site per year.

⁴Based on \$25 per site per month.

⁵Based on \$100 per month per vehicle.

⁶Based on \$200 per site per year plus \$2,000 for helicopter service.

⁷Based on \$150 per site per month.